

**Declared qualities stated**

Harmonised technical specification	EN 13240 ✓ EN 13229	EN 16510 ✓ Ecodesign	✓ DIN+ ✓ BImSchV2	DIBt ✓ 15a B-VG 2015
Classification of appliance	Type BE			
Energy efficiency ( $\eta_{nom}$ )	82,3 %			
The energy efficiency index	109,4			
Energy label	A+			
Fuel	Wood logs			
Fuel length	250-400 mm			
Average fuel consumption	2,2 kg/h			
Allowed fuel dose	2,9 kg/h			
Fuel supply interval	1 hour			
Amount of combustion air	27,9 m <sup>3</sup> /h			
Nominal output ( $P_{nom}$ )	7,9 kW			
Hot-water exchanger output ( $P_{Wnom}$ )	--- kW			
Maximum operating overpressure ( $p_w$ )	--- bar			
Dry flue gas mass flow rate to calculate the flue gas path	6,2 g/s			
Flue gas temperature ( $T_{nom}$ )	246 °C			
Mean flue gas temperature after throat	258 °C			
Flue draught ( $p_{nom}$ )	12 Pa			
Chimney temperature class	T400			
Connection to the common chimney	Yes			
Storage of fuel in the wood shed area	No			
Maximum warming of the wood in the wood shed	--- °C			
Dust O <sub>2</sub> = 13 % ( $PM_{nom}$ )	25 mg/Nm <sup>3</sup>			
Emissions of gases of combustion (CO in the flue gases at O <sub>2</sub> = 13 %) ( $CO_{nom}$ )	0,0890 % 1113 mg/Nm <sup>3</sup>			
OGC O <sub>2</sub> = 13 % ( $OGC_{nom}$ )	52 mg/Nm <sup>3</sup>			
NO <sub>x</sub> O <sub>2</sub> = 13 % ( $NO_{xnom}$ )	107 mg/Nm <sup>3</sup>			
Automatic regulation unit of burning	---			
Power consumption (W)	---			
Standing air loss (V <sub>h</sub> )	---			
Intermittent operation (INT) / Continuous operation (CON)	INT			

**Basic technical data**

Principal dimensions Height (H)   Width (W)   Length (L)	1192   808   570	mm
Combustion chamber dimensions Height (H)   Width (W)   Length (L)	472   628   390	mm
Fireplace door dimensions Height (H)   Width (W)   Length (L)	467   664   ---	mm
Axis height of the rear (side) outlet	---	mm
Volume of hot-water exchanger	---	l
Flue diameter	150-180	mm
Diameter of flue throat ( $D_{out}$ )	180	mm
Diameter of external air connection	150	mm
Weight	190	kg
Area of Inlet ventilation grille	600	cm <sup>2</sup>
Area of Outlet ventilation grille	800	cm <sup>2</sup>

Distances from flammable materials	Note		
Back ( $d_R$ )		800	mm
Front ( $d_F$ )		800	mm
Front to the floor ( $d_F$ )		---	mm
Side ( $d_S$ )	*	400	mm
Side with glass ( $d_{S1}$ )		---	mm
Side - niche ( $d_{S2}$ )		---	mm
Side - location 45° ( $d_{S3}$ )		---	mm
Side radiation ( $d_L$ )		---	mm
From the floor ( $d_B$ )		---	mm
From the ceiling ( $d_C$ )		800	mm
From the back and side edge of the fireplace insert to the inside of the insulation ( $d_{S4}$ )	*	120	mm

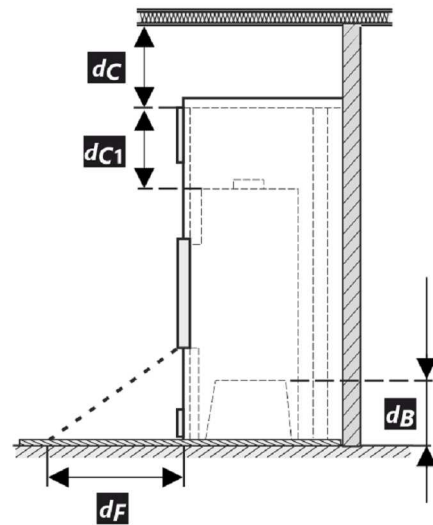
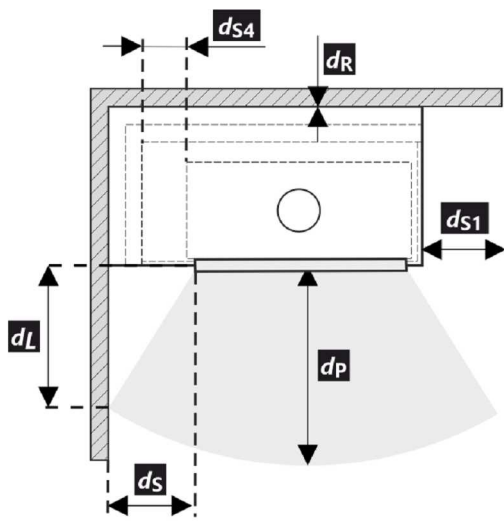

All local regulations, including regulations relating to national and European standards, must be observed during the installation and operation of the product.

- \* If the distance from the door glass to the combustible side wall is  $d_S < 400$  mm and must not be  $d_{S4} < 120$  mm, this wall must be protected by a 40 mm wide SILCA 250 insulation board or an adequate substitute.

Legend	Note	Description	Material	Dimension
1		Appliance	230F 0000 001	
2		Flue gas outlet	metal	DN150-180
3		Insulation of the flue gas connection		
4		Mineral insulation		
5		Convection air space around the appliance		
6		Protective insulation of walls	SILCA 250	2x50 mm
6A		Protective ceiling insulation	SILCA 250	80 mm
7		Protective wall	hollow burnt brick	100 mm
8		Combustible wall		
9		Concrete slab		
10		Combustible floor		

<b>11</b>	Decorative / ornamental beam		
<b>12</b>	Beam with ventilation air gap		
<b>13</b>	Convection air inlet		600 cm <sup>2</sup>
<b>14</b>	Convection air outlet		800 cm <sup>2</sup>
<b>15</b>	Lining	SILCA 250	40 mm
<b>16</b>	Support frame		
<b>17</b>	Combustible ceiling		
<b>18</b>	Protective insulation board for combustible floors	SILCA 250	40 mm
<b>19</b>	Combustion air regulation		
<b>20</b>	Sheet metal cover if mineral wool is used		
<b>21</b>	If necessary, a floor protection plate under the appliance		
<b>d<sub>c</sub></b>	From the top of the exhaust vent to the combustible ceiling		800 mm
<b>d<sub>c1</sub></b>	– From the top of the fireplace insert to the underside of the ceiling insulation – In the case of an installed heat exchanger from the top edge of the heat exchanger to the underside of the ceiling insulation		300 mm --- mm
<b>d<sub>s4</sub></b>	<b>*</b> From the back and side edge of the fireplace insert to the inside of the insulation		120 mm
<b>d<sub>s5</sub></b>	From the front edge of the fireplace insert to the inside of the insulation		10 mm
<b>d<sub>B</sub></b>	From the bottom of the fireplace insert to the fireproof floor		--- mm

**Caution:** Fire protection / insulation boards SILCA 250 (SILCA® 250SB, thickness 40 mm) can be replaced by a suitable nonflammable material with a thermal conductivity  $\leq 1,1 \text{ W}\cdot\text{m}^{-1}\cdot\text{K}^{-1}$  ( $\lambda$ ).

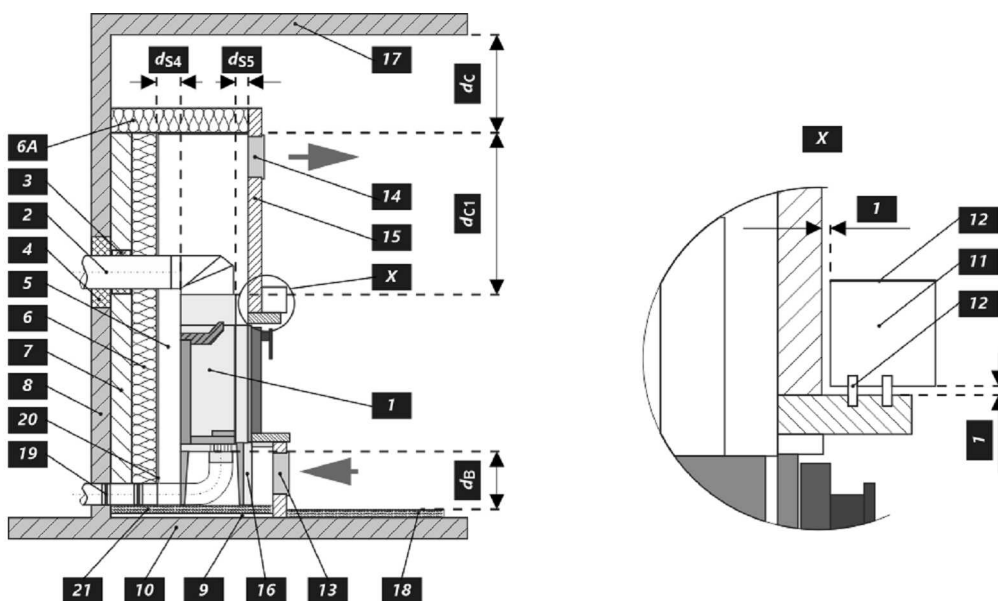

**Deklarierte Produkteigenschaften**

Harmonisierte technische Spezifikation	EN 13240 ✓ EN 13229	EN 16510 ✓ Ecodesign	✓ DIN+ ✓ BImSchV2	DIBt ✓ 15a B-VG 2015
Produktklassifizierung	Type BE			
Energiewirkungsgrad ( $\eta_{nom}$ )	82,3 %			
Energieeffizienzindex	109,4			
Energielabel	A+			
Brennstoff	Scheitholz			
Brennstofflänge	250-400 mm			
Durchschnittlicher Brennstoffverbrauch	2,2 kg/h			
Zulässiger Brennstoffverbrauch	2,9 kg/h			
Brennstofflieferintervall	1 Stunde			
Verbrennungsluftmenge	27,9 m <sup>3</sup> /h			
Nennwärmeleistung ( $P_{nom}$ )	7,9 kW			
Wärmetauscherleistung ( $P_{Wnom}$ )	--- kW			
Maximaler Betriebsüberdruck ( $p_w$ )	--- bar			
Rauchgasmassenstrom (trocken) für die Berechnung der Rauchgaswege	6,2 g/s			
Durchschnittliche Abgastemperatur ( $T_{nom}$ )	246 °C			
Durchschnittliche Rauchgastemperatur hinter dem Stutzen	258 °C			
Förderdruck ( $p_{nom}$ )	12 Pa			
Temperaturklasse	T400			
Mehrfachbelegung	Ja			
Lagerung von Brennstoff im Holzfach	Nein			
Maximale Erwärmung des Holzes im Holzfach	--- °C			
Feinstaub O <sub>2</sub> = 13 % ( $PM_{nom}$ )	25 mg/Nm <sup>3</sup>			
Abgasemission (CO in den Abgasen bei O <sub>2</sub> = 13 %) ( $CO_{nom}$ )	0,0890 % 1113 mg/Nm <sup>3</sup>			
OGC O <sub>2</sub> = 13 % ( $OGC_{nom}$ )	52 mg/Nm <sup>3</sup>			
NO <sub>x</sub> O <sub>2</sub> = 13 % ( $NO_{xnom}$ )	107 mg/Nm <sup>3</sup>			
Automatische Abbrandsteuerung	---			
Stromverbrauch (W)	--- W			
Ständiger Luftverlust ( $V_h$ )	--- m <sup>3</sup> <sub>N</sub> /h			
Intervallbetrieb (INT) / Dauerbetrieb (CON)	INT			

**Technische Grunddaten**

Hauptabmessungen Höhe (H)   Breite (W)   Tiefe (L)	1192   808   570	mm
Abmessungen der Brennkammer Höhe (H)   Breite (W)   Tiefe (L)	472   628   390	mm
Abmessungen der Feuerraumtür Höhe (H)   Breite (W)   Tiefe (L)	467   664   ---	mm
Achshöhe hinterer (seitlichen) Rauchrohanschluss	---	mm
Volumen Wärmetauscher	---	l
Rauchrohrdurchmesser	150-180	mm
Abgasstutzen ( $D_{out}$ )	180	mm
Durchmesser zentrale Luftzufuhr	150	mm
Gewicht	190	kg
Fläche Zuluftgitter	600	cm <sup>2</sup>
Fläche Abluftgitter	800	cm <sup>2</sup>

Abstand zu brennbaren Materialien	Bemerkung		
Rückwand ( $d_R$ )		800	mm
Strahlungsbereich ( $d_P$ )		800	mm
Strahlungsbereich zum Boden ( $d_F$ )		---	mm
Seitenwände ( $d_S$ )	*	400	mm
Seite mit Glas ( $d_{S1}$ )		---	mm
Seite – Nische ( $d_{S2}$ )		---	mm
Seite – Ausrichtung 45° ( $d_{S3}$ )		---	mm
Seitliche Strahlung ( $d_L$ )		---	mm
Von dem Boden ( $d_B$ )		---	mm
Decke ( $d_C$ )		800	mm
Von der hinteren- und seitlichen Kante des Kamineinsatzes bis zur Innenseite der Isolierung ( $d_{S4}$ )	*	120	mm

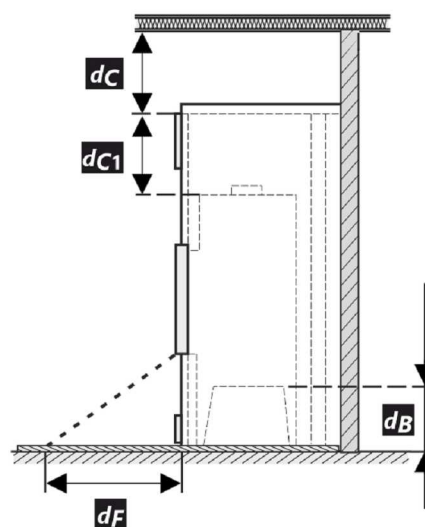
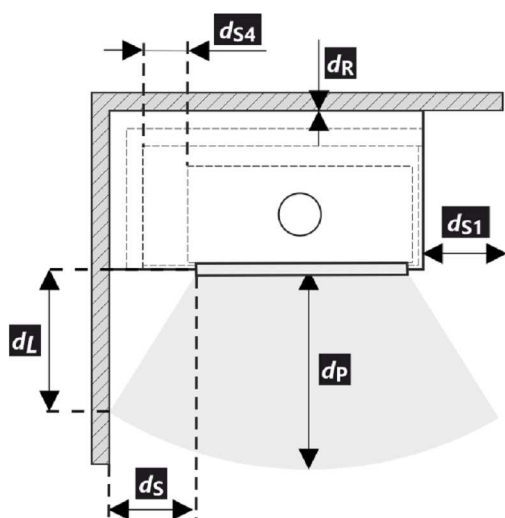

Bei der Installation und dem Betrieb des Ofens sind alle örtlichen Vorschriften sowie nationale und europäische Normen zu beachten.

- \* Wenn der Abstand vom Türglas zur brennbaren Seitenwand  $d_S < 400$  mm beträgt und nicht  $d_{S4} < 120$  mm sein darf, muss diese Wand durch eine 40 mm breite SILCA 250 Dämmplatte oder einen geeigneten Ersatz geschützt werden.

Legende	Bemerkung	Beschreibung	Material	Maß
1	Gerät		230F 0000 001	
2	Rauchgasabgang		metall	DN150-180
3	Isolierung Anschluss Rauchgasabgang			
4	Mineralwolleisolierung			
5	Konvektionsraum um das Gerät			
6	Schutzisolierung der Wände		SILCA 250	2x50 mm
6A	Schutzisolierung der Decke		SILCA 250	80 mm
7	Schutzwand		gebrannter hohlziegel	100 mm
8	Brennbare Wand			
9	Betonplatte			
10	Brennbarer Boden			

11	Dekorativer Träger		
12	Träger mit Belüftungsspalt		
13	Konvektionslufteinlass		600 cm <sup>2</sup>
14	Konvektionsluftauslass		800 cm <sup>2</sup>
15	Verkleidung	SILCA 250	40 mm
16	Tragrahmen		
17	Brennbare Decke		
18	Schutzisolierungsplatte des brennbaren Bodens	SILCA 250	40 mm
19	Verbrennungsluftregulierung		
20	Blechabdeckung bei Verwendung von Mineralwolle		
21	Falls nötig eine Bodenschutzplatte unter dem Gerät		
<b>d<sub>c</sub></b>	Von der Oberkante der Abluftöffnung bis zur brennbaren Decke		800 mm
<b>d<sub>c1</sub></b>	– Von der Oberkante des Kamineinsatzes bis zur Unterkante der Deckenisolierung – Im Falle eines eingebauten Wärmetauschers – von der Oberkante des Wärmetauschers bis zur Unterseite der Deckenisolierung		300 mm --- mm
<b>d<sub>s4</sub></b>	* Von der hinteren- und seitlichen Kante des Kamineinsatzes bis zur Innenseite der Isolierung		120 mm
<b>d<sub>ss</sub></b>	Von der Vorder Kante des Kamineinsatzes bis zur Innenseite der Isolierung		10 mm
<b>d<sub>B</sub></b>	Von der Unterseite des Kamineinsatzes bis zum feuerfesten Boden		--- mm

**Warnhinweise:** Brandschutz- / Dämmplatten SILCA 250 (SILCA® 250SB, Dicke 40 mm) kann durch ein geeignetes nicht brennbares Material mit einer Wärmeleitfähigkeit ( $\lambda$ )  $\leq 1,1 \text{ W} \cdot \text{m}^{-1} \cdot \text{K}^{-1}$  ersetzt werden.

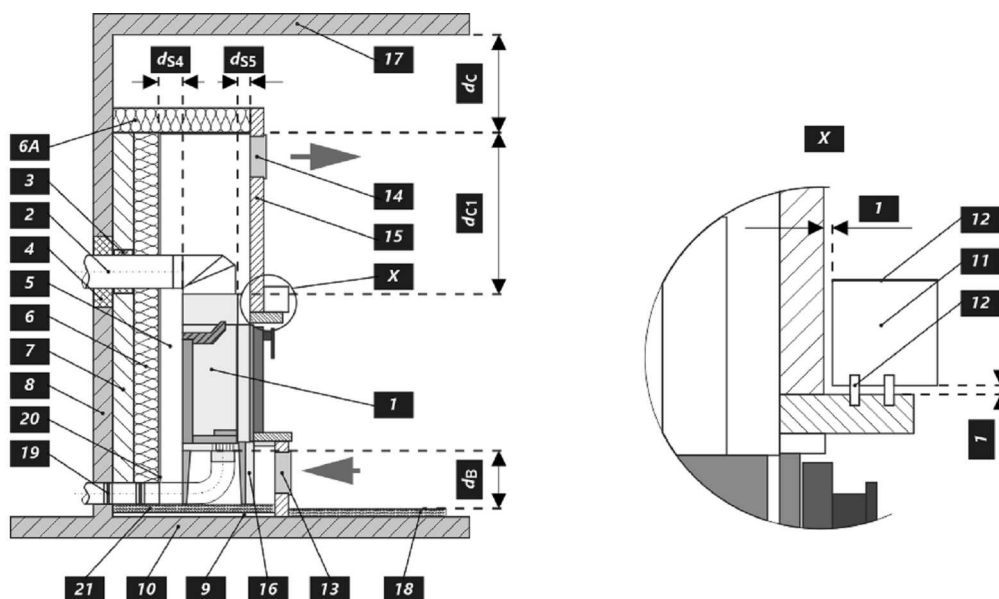

**Caractéristiques déclarées du produit**

Norme(s) Européennes	EN 13240 ✓ EN 13229	EN 16510 ✓ Ecodesign	✓ DIN+ ✓ BImSchV2	DIBt ✓ 15a B-VG 2015
Classification de l'appareil	Type BE			
Rendement énergétique ( $\eta_{nom}$ )				82,3 %
L'indice d'efficacité énergétique EEI				109,4
Label énergétique				A+
Combustible				Bûches
Longueur recommandée de bûches				250-400 mm
Consommation moyenne de combustible				2,2 kg/h
Charge en bois autorisé				2,9 kg/h
Intervalle entre les chargements de combustible				1 heure
Débit massique des fumées				27,9 m <sup>3</sup> /h
Puissance nominale ( $P_{nom}$ )				7,9 kW
Puissance nominale de l'échangeur ( $P_{Wnom}$ )				--- kW
Suppression maximale de fonctionnement ( $p_w$ )				--- bar
Débit massique des gaz de combustion secs pour le calcul des gaz de combustion				6,2 g/s
Température moyenne des résidus de combustion ( $T_{nom}$ )				246 °C
Température moyenne des résidus de combustion derrière la sortie				258 °C
Tirage de conduit de fumée ( $p_{nom}$ )				12 Pa
Classe de température				T400
Raccordement à une cheminée collective				Oui
Stockage du combustible dans range bûches				Non
Réchauffement maximal du bois dans range bûches				--- °C
Poussière O <sub>2</sub> = 13 % ( $PM_{nom}$ )				25 mg/Nm <sup>3</sup>
Résidus de combustion émis (CO dans les résidus de combustion pour O <sub>2</sub> = 13 %) ( $CO_{nom}$ )				0,0890 % 1113 mg/Nm <sup>3</sup>
OGC O <sub>2</sub> = 13 % ( $OGC_{nom}$ )				52 mg/Nm <sup>3</sup>
NOx O <sub>2</sub> = 13 % ( $NO_{xnom}$ )				107 mg/Nm <sup>3</sup>
Régulation automatique de la combustion				---
La consommation d'électricité (W)				--- W
Standing air loss ( $V_h$ )				--- m <sup>3</sup> /h
Fonctionnement par intermittence (INT) / Service ininterrompu (CON)				INT

**Données techniques de base**

Dimensions principales Hauteur (H)   Largeur (W)   Profondeur (L)	1192   808   570	mm
Dimensions de la chambre de combustion Hauteur (H)   Largeur (W)   Profondeur (L)	472   628   390	mm
Dimensions de la porte (du foyer) Hauteur (H)   Largeur (W)   Profondeur (L)	467   664   ---	mm
Hauteur de l'axe de la sortie arrière (latérale)	---	mm
Volume de l'échangeur de chaleur	---	l
Diamètre du conduit de fumée	150-180	mm
Diamètre de buse d'air de combustion ( $D_{out}$ )	180	mm
Diamètre de l'arrivée d'air centrale	150	mm
Poids	190	kg
Zone de la grille de ventilation d'entrée	600	cm <sup>2</sup>
Zone de la grille de ventilation de sortie	800	cm <sup>2</sup>

Isolation protectrice des plafonds	Note		
Arrière ( $d_R$ )		800	mm
Avant ( $d_P$ )		800	mm
Avant (par rapport au sol) ( $d_F$ )		---	mm
Latéral ( $d_S$ )	*	400	mm
Latéral avec vitre ( $d_{S1}$ )		---	mm
Latéral – niche ( $d_{S2}$ )		---	mm
Latéral – emplacement 45° ( $d_{S3}$ )		---	mm
Rayonnement latéral ( $d_L$ )		---	mm
Depuis le sol ( $d_B$ )		---	mm
Plafond ( $d_C$ )		800	mm
Du bord arrière et latéral de l'insert de cheminée jusqu'à l'intérieur de l'isolation ( $d_{S4}$ )	*	120	mm

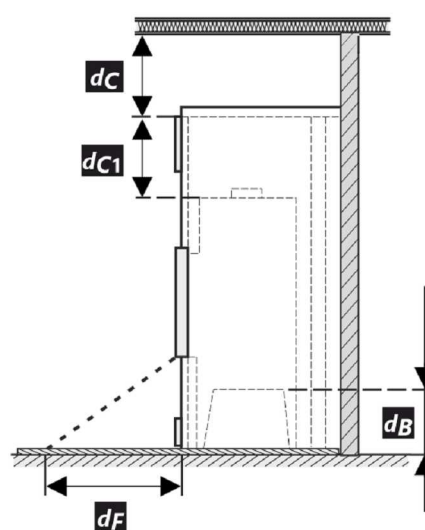
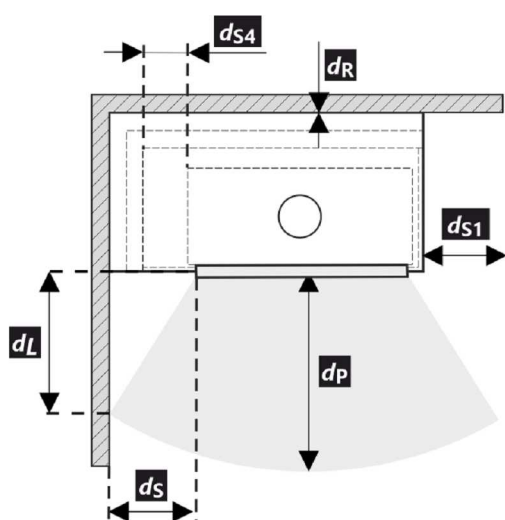

Lors de l'installation et de l'utilisation du produit, toutes les réglementations locales doivent être respectées, y compris celles relatives aux normes nationales et européennes.

- \* Si la distance entre la vitre de la porte et la paroi latérale combustible est  $d_S < 400$  mm et ne doit pas être  $d_{S4} < 120$  mm, cette paroi doit être protégée par un panneau isolant SILCA 250 de 40 mm de large ou un substitut approprié.

Légende	Note	Description	Matériel	Dimension
1		Appareil ménager	230F 0000 001	
2		Extraction des résidus de combustion	métal	DN150-180
3		Isolation du raccordement des résidus de combustion		
4		Isolation minérale		
5		Espace de convection autour de l'appareil		
6		Isolation protectrice des murs	SILCA 250	2x50 mm
6A		Isolation protectrice des plafonds	SILCA 250	80 mm
7		Mur de protection	brique creuse cuite	100 mm
8		Mur inflammable		
9		Plaque de béton		
10		Sol inflammable		



11	Support décoratif / ornemental		
12	Support avec espace de ventilation		
13	Entrée d'air de convection		600 cm <sup>2</sup>
14	Sortie d'air de convection		800 cm <sup>2</sup>
15	Habillage	SILCA 250	40 mm
16	Cadre de support		
17	Plafond inflammable		
18	Panneau isolant de protection pour sols combustibles	SILCA 250	40 mm
19	Régulation de l'air de combustion		
20	Couverture en tôle si de la laine minérale est utilisée		
21	Si nécessaire, une plaque de sol de protection située sous l'appareil		
<b>d<sub>c</sub></b>	Du haut du conduit d'évacuation au plafond combustible		800 mm
<b>d<sub>c1</sub></b>	– Du haut de l'insert de cheminée jusqu'au bas de l'isolation du plafond – Dans le cas d'un échangeur de chaleur installé – du bord supérieur de l'échangeur de chaleur à la partie inférieure de l'isolation du plafond.		300 mm --- mm
<b>d<sub>s4</sub></b>	*	Du bord arrière et latéral de l'insert de cheminée jusqu'à l'intérieur de l'isolation	120 mm
<b>d<sub>s5</sub></b>		Du bord avant de l'insert de cheminée à l'intérieur de l'isolation	10 mm
<b>d<sub>B</sub></b>		Du bas de l'insert de cheminée jusqu'au sol incombustible	--- mm

**Avertissement:** Panneaux ignifuges / isolants SILCA 250 (SILCA® 250SB, épaisseur 40 mm) peut être remplacé par un matériau non combustible approprié avec une conductivité thermique  $\leq 1,1 \text{ W}\cdot\text{m}^{-1}\cdot\text{K}^{-1}$  ( $\lambda$ ).

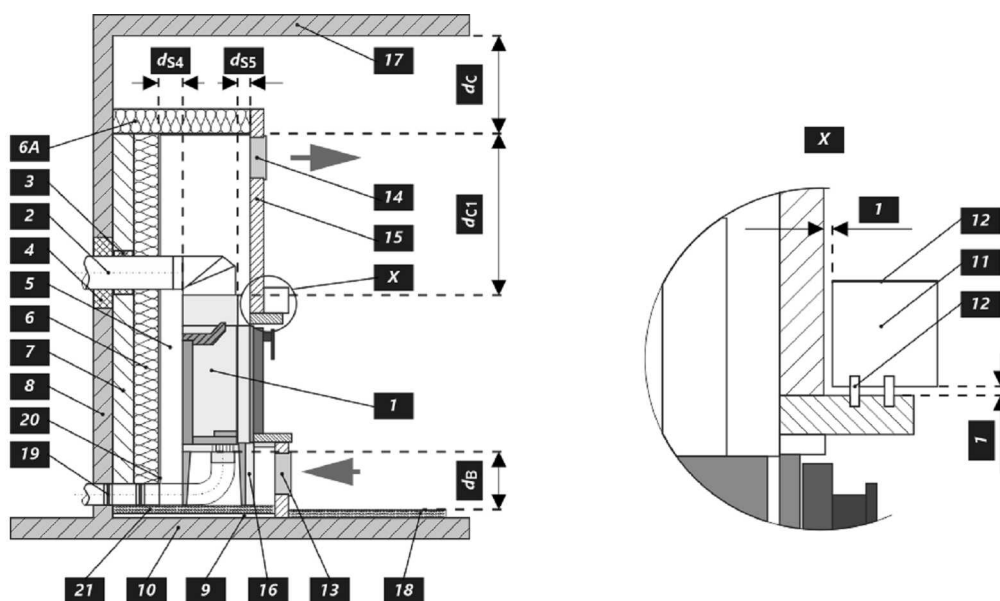

**Proprietà dichiarate del prodotto**

Specificazioni tecniche armonizzate	EN 13240 ✓ EN 13229	EN 16510 ✓ Ecodesign	✓ DIN+ ✓ BImSchV2	DIBt ✓ 15a B-VG 2015	
Classificazione del prodotto					Type BE
Efficienza energetica ( $\eta_{nom}$ )					82,3 %
Indice di efficienza prodotto					109,4
Etichetta energetica					A+
Combustibile					Legna
Combustibile – lunghezza					250-400 mm
Consumo medio di combustibile					2,2 kg/h
Dose ammessa di combustibile					2,9 kg/h
Intervallo di aggiunta di combustibile					1 ora
Quantità di aria di combustione					27,9 m <sup>3</sup> /h
Protenza nominale ( $P_{nom}$ )					7,9 kW
Protenza nominale dello scambiatore di acqua calda ( $P_{Wnom}$ )					--- kW
Sovrappressione massima di funzionamento ( $p_w$ )					--- bar
Portata dei fumi di scarico secchi per il calcolo delle condotte dei fumi di scarico					6,2 g/s
Temperatura dei gas combusti alla potenza calorica nominale ( $T_{nom}$ )					246 °C
Temp. media dei gas di scarico al collo alla potenza termica nominale					258 °C
Tiro di esercizio ( $p_{nom}$ )					12 Pa
Classe di temperatura del camino					T400
Collegamento al camino collettivo					Sì
Stoccaggio del combustibile nell'area della stufa a legna					No
Riscaldamento massimo della legna nella stufa a legna					--- °C
Polvere O <sub>2</sub> = 13 % ( $PM_{nom}$ )					25 mg/Nm <sup>3</sup>
Emissioni (CO nei gas comburenti all' O <sub>2</sub> = 13 %) ( $CO_{nom}$ )					0,0890 % 1113 mg/Nm <sup>3</sup>
OGC O <sub>2</sub> = 13 % ( $OGC_{nom}$ )					52 mg/Nm <sup>3</sup>
NOx O <sub>2</sub> = 13 % ( $NO_{Xnom}$ )					107 mg/Nm <sup>3</sup>
Controllo automatico della combustione					---
Consumo di energia elettrica (W)					--- W
Perdita d'aria in piedi ( $V_h$ )					--- m <sup>3</sup> /h
Funzionamento intermittente (INT) / Funzionamento continuo (CON)					INT

**Dati tecnici di base**

Dimensioni principali Altezza (H)   Larghezza (W)   Profondità (L)	1192   808   570	mm
Dimensioni della camera di combustione Altezza (H)   Larghezza (W)   Profondità (L)	472   628   390	mm
Dimensioni dello sportello del focolare Altezza (H)   Larghezza (W)   Profondità (L)	467   664   ---	mm
Altezza dell'asse dell'uscita posteriore (laterale)	---	mm
Volume dello scambiatore di acqua calda	---	l
Diametro del condotto fumario	150-180	mm
Diametro del gola della canna fumaria ( $D_{out}$ )	180	mm
Diametro dell'afflusso centralizzato di aria	150	mm
Peso	190	kg
Superficie della griglia di aerazione d'ingresso	600	cm <sup>2</sup>
Superficie della griglia di aerazione d'uscita	800	cm <sup>2</sup>

Distanza di materiali infiammabili	Nota		
Posteriore ( $d_R$ )		800	mm
Anteriore ( $d_P$ )		800	mm
Anteriore (rispetto al pavimento) ( $d_F$ )		---	mm
Laterali ( $d_S$ )	*	400	mm
Vetrata laterale ( $d_{S1}$ )		---	mm
Laterali - nicchia ( $d_{S2}$ )		---	mm
Laterali - posizione 45° ( $d_{S3}$ )		---	mm
Radiazione laterale ( $d_L$ )		---	mm
Dal pavimento ( $d_B$ )		---	mm
Dal soffitto ( $d_C$ )		800	mm
Dal bordo posteriore e laterale dell'insero del caminetto fino all'interno dell'isolazione ( $d_{S4}$ )	*	120	mm

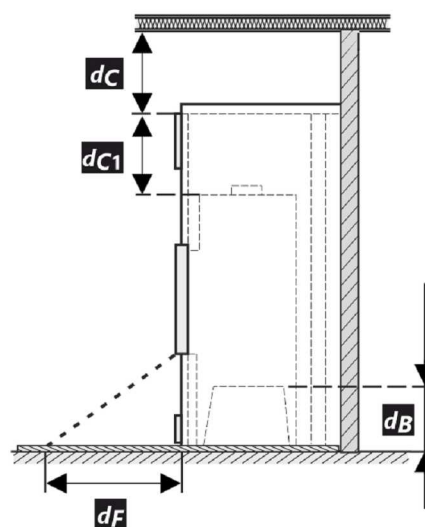
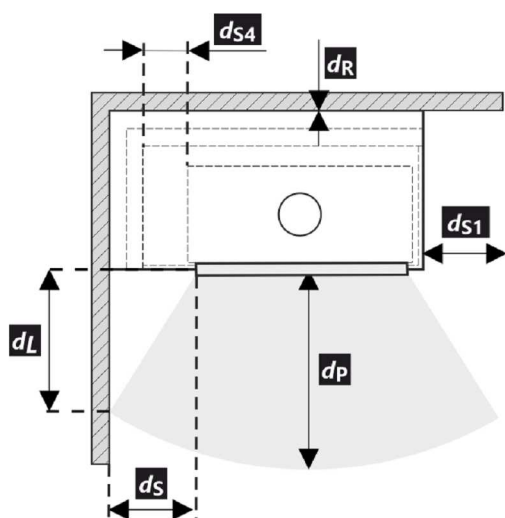

Durante il montaggio e l'uso del prodotto, devono essere rispettate tutte le normative locali, incluse le norme nazionali ed europee.

- \* Se la distanza dal vetro della porta alla parete laterale combustibile è  $d_S < 400$  mm e non deve essere  $d_{S4} < 120$  mm, questa parete deve essere protetta da un pannello isolante SILCA 250 largo 40 mm o da un idoneo sostituto.

Legenda	Nota	Descrizione	Materiale	Dimensione
1		Apparecchio	230F 0000 001	
2		Scarico fumi	metallo	DN150-180
3		Isolamento del raccordo scarico fumi		
4		Isolamento minerale		
5		Spazio d'aria di convezione intorno all'insero		
6		Isolazione della parete	SILCA 250	2x50 mm
6A		Isolazione del soffitto	SILCA 250	80 mm
7		Parete di protezione	refrattario trafialto	100 mm
8		Parete infiammabile		
9		Lastra di calcestruzzo		
10		Pavimento infiammabile		

<b>11</b>	Trave decorativa		
<b>12</b>	Trave con intercapedine di ventilazione		
<b>13</b>	Ingresso aria di convezione		600 cm <sup>2</sup>
<b>14</b>	Uscita aria di convezione		800 cm <sup>2</sup>
<b>15</b>	Rivestimento	SILCA 250	40 mm
<b>16</b>	Telaio di supporto		
<b>17</b>	Soffitto ininfiammabile		
<b>18</b>	Pannello isolante protettivo per pavimenti ininfiammabili	SILCA 250	40 mm
<b>19</b>	Gestione dell'aria comburente		
<b>20</b>	Copertura in lamiera con utilizzo di lana di roccia		
<b>21</b>	Se necessario, piastra di protezione sotto l'apparecchio		
<b>d<sub>c</sub></b>	Dall'alto della bocchetta aria superiore al soffitto combustibile		800 mm
<b>d<sub>c1</sub></b>	- Dalla parte superiore dell'inserto caminetto alla parte inferiore dell'isolazione del soffitto		300 mm
	- In caso di utilizzo scambiatore di calore, dal bordo superiore dello scambiatore alla parte inferiore dell'isolamento del soffitto		--- mm
<b>d<sub>s4</sub></b>	* Dal bordo posteriore e laterale dell'inserto del caminetto fino all'interno dell'isolazione		120 mm
<b>d<sub>s5</sub></b>	Dal bordo anteriore dell'inserto caminetto fino all'interno dell'isolazione		10 mm
<b>d<sub>B</sub></b>	Dal fondo dell'inserto caminetto al pavimento ignifugo		--- mm

**Avviso:** I pannelli di protezione antincendio / isolamento SILCA 250 (SILCA® 250SB, spessore 40 mm) possono essere sostituiti da un materiale non ininfiammabile adatto con una conduttività termica  $\leq 1,1 \text{ W} \cdot \text{m}^{-1} \cdot \text{K}^{-1} (\lambda)$ .

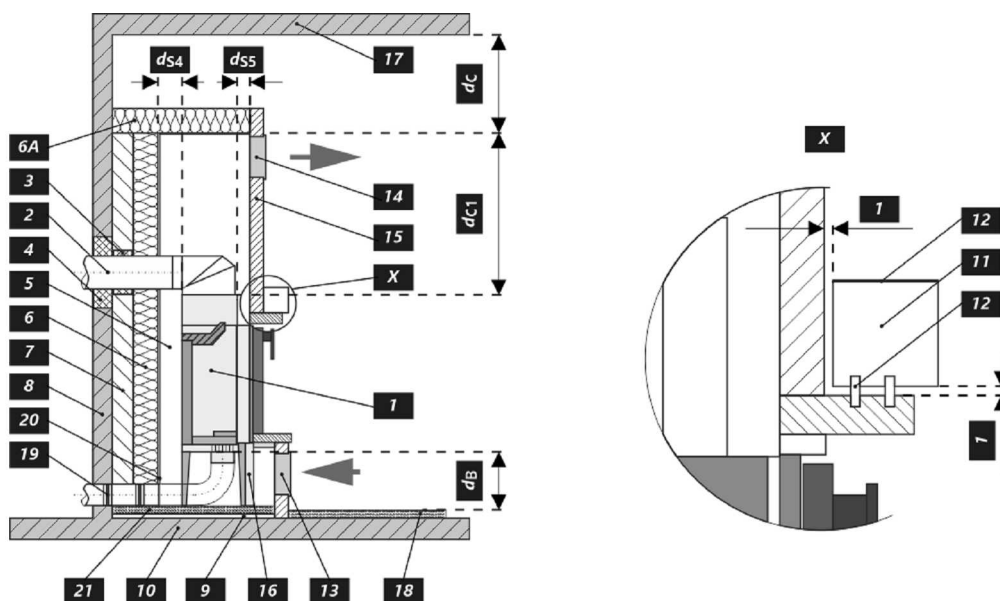

**Deklaracija lastnosti**

Harmonizirana tehnična specifikacija	EN 13240 ✓ EN 13229	EN 16510 ✓ Ecodesign	✓ DIN+ ✓ BlmSchV2	DIBt ✓ 15a B-VG 2015
Klasifikacija izdelka	Type BE			
Energetska učinkovitost ( $\eta_{nom}$ )				82,3 %
Indeks energetske učinkovitosti				109,4
Energijska nalepka				A+
Gorivo				Drva
Priporočljiva dolžina goriva				250-400 mm
Povprečna poraba lesa				2,2 kg/h
Dovoljena količina lesa				2,9 kg/h
Interval dobave goriva za nazivno moč				1 ura
Zahtevan zrak za izgorevanje				27,9 m <sup>3</sup> /h
Nazivna moč ( $P_{nom}$ )				7,9 kW
Izhod toplovodnega izmenjevalnika ( $P_{Wnom}$ )				--- kW
Delovni tlak ( $p_w$ )				--- bar
Masni pretok huhih dimnih plinov				6,2 g/s
Srednja temperatura plinov pri nazivni toplotni moči ( $T_{nom}$ )				246 °C
Srednja temperatura dimnih plinov po grlu pri nazivni toplotni moči				258 °C
Vlek dimnika ( $p_{nom}$ )				12 Pa
Temperaturni razred kamina				T400
Priključek na skupni dimnik				Da
Skladiščenje goriva v območju peči				Ne
Maksimalno segrevanje lesa v območju peči na drva				--- °C
Prah O <sub>2</sub> = 13 % ( $PM_{nom}$ )				25 mg/Nm <sup>3</sup>
Emisije izgorovalnih plinov (CO v dimne pline pri O <sub>2</sub> = 13 %) ( $CO_{nom}$ )				0,0890 % 1113 mg/Nm <sup>3</sup>
OGC O <sub>2</sub> = 13 % ( $OGC_{nom}$ )				52 mg/Nm <sup>3</sup>
NO <sub>x</sub> O <sub>2</sub> = 13 % ( $NO_{xnom}$ )				107 mg/Nm <sup>3</sup>
Avtomatska regulacija gorenja				---
Poraba električne energije (W)				--- W
Stalna izguba zraka ( $V_h$ )				--- m <sup>3</sup> /h
Prekinjeno delovanje (INT) / Nprekinjeno delovanje (CON)				INT

**Osnovni tehnični podatki**

Dimenzije Višina (H)   Širina (W)   Globina (L)	1192   808   570	mm
Dimenzije zgorevalne komore Višina (H)   Širina (W)   Globina (L)	472   628   390	mm
Dimenzije vrat peči Višina (H)   Širina (W)   Globina (L)	467   664   ---	mm
Višina osi zadnjega (stranskega) izpusta	---	mm
Prostornina toplotnega izmenjevalnika	---	l
Premer priključka dimne cevi	150-180	mm
Premer dimne cevi ( $D_{out}$ )	180	mm
Zunanji dovod zraka (ZDZ)	150	mm
Teža	190	kg
Minimalni presek konvektne odprtine za dovod zraka za nazivno moč	600	cm <sup>2</sup>
Minimalni presek konvektne odprtine za odvod zraka za nazivno moč	800	cm <sup>2</sup>

## Varna razdalja od vnetljivih materialov

## Opomba

Zadaj ( $d_R$ )		800	mm
Spredaj ( $d_P$ )		800	mm
Stran od tal ( $d_F$ )		---	mm
Stran ( $d_S$ )	*	400	mm
Stran s steklom ( $d_{S1}$ )		---	mm
Stran – niša ( $d_{S2}$ )		---	mm
Stran – postavitvev pod kotom 45° ( $d_{S3}$ )		---	mm
Stransko sevanje ( $d_L$ )		---	mm
Od tal ( $d_B$ )		---	mm
Od stropa ( $d_C$ )		800	mm
Od zadnjega in stranskega roba kaminskega vložka do notranje strani izolacije ( $d_{S4}$ )	*	120	mm

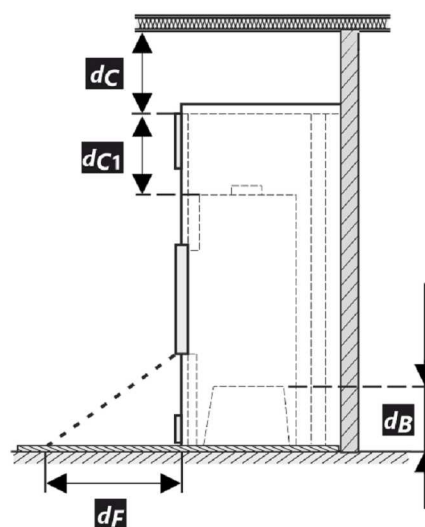
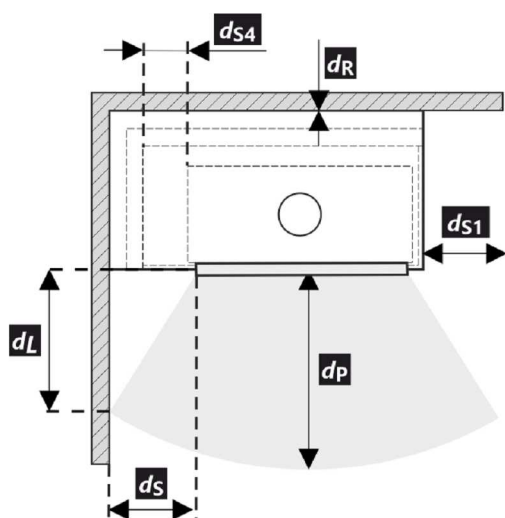

Pri montaži in delovanju izdelka morajo biti upoštevani vsi lokalni predpisi, vključno predpisi, ki se nanašajo na lokalne in Evropske standarde.

- \* Če je razdalja od stekla vrat do gorljive stranske stene  $d_S < 400$  mm, pri čemer ne sme biti  $d_{S4} < 120$  mm, se mora ta zid zavarovati z izolativno desko SILCA 250 širine 40 mm, ali pa ustreznim nadomestilom.

Legenda	Opomba	Opis	Material	Dimenzija
1		Naprava	230F 0000 001	
2		Odvod dimnih plinov	kov	DN150-180
3		Izolacija priključka za odvod dimnih plinov		
4		Mineralna izolacija		
5		Konvekcijski zračni prostor okoli naprave		
6		Zaščitna izolacija sten	SILCA 250	2x50 mm
6A		Zaščitna izolacija stropa	SILCA 250	80 mm
7		Zaščitna stena	votla žgana opeka	100 mm
8		Gorljiva stena		
9		Betonska plošča		
10		Gorljiva podlaga		

11	Dekoratívni / okrasni nosilec		
12	Nosilec s prezračevalno zračno režo		
13	Vhod konvekcijskega zraka		600 cm <sup>2</sup>
14	Izhod konvekcijskega zraka		800 cm <sup>2</sup>
15	Obloga	SILCA 250	40 mm
16	Nosilni okvir		
17	Gorljiv strop		
18	Zaščitna izolacijska deska	SILCA 250	40 mm
19	Regulacija zraka za izgorevanje		
20	Pločevinasti pokrov v primeru uporabe mineralne volne		
21	Po potrebi zaščitna talna plošča pod napravo		
<b>d<sub>c</sub></b>	Od vrha odvoda zraka do gorljivega stropa		800 mm
<b>d<sub>cl</sub></b>	– Od vrha kaminskega vložka do spodnje strani stropne izolacije – Pri vgrajenem toplotnem izmenjevalniku – od zornjega roba toplotnega izmenjevalnika do spodnje strani stropne izolacije		300 mm --- mm
<b>d<sub>s4</sub></b>	*	Od zadnjega in stranskega roba kaminskega vložka do notranje strani izolacije	120 mm
<b>d<sub>s5</sub></b>		Od sprednjega roba kaminskega vložka do notranje strani izolacije	10 mm
<b>d<sub>B</sub></b>		Od dna kaminskega vložka do ognjevarne podlage	--- mm

**Opomba:** Protipožarne / izolacijske plošče SILCA 250 (SILCA® 250SB, debeline 40 mm) se lahko nadomestijo z ustreznim negorljivim materialom s toplotno prevodnostjo  $\leq 1,1 \text{ W}\cdot\text{m}^{-1}\cdot\text{K}^{-1}$  ( $\lambda$ ).

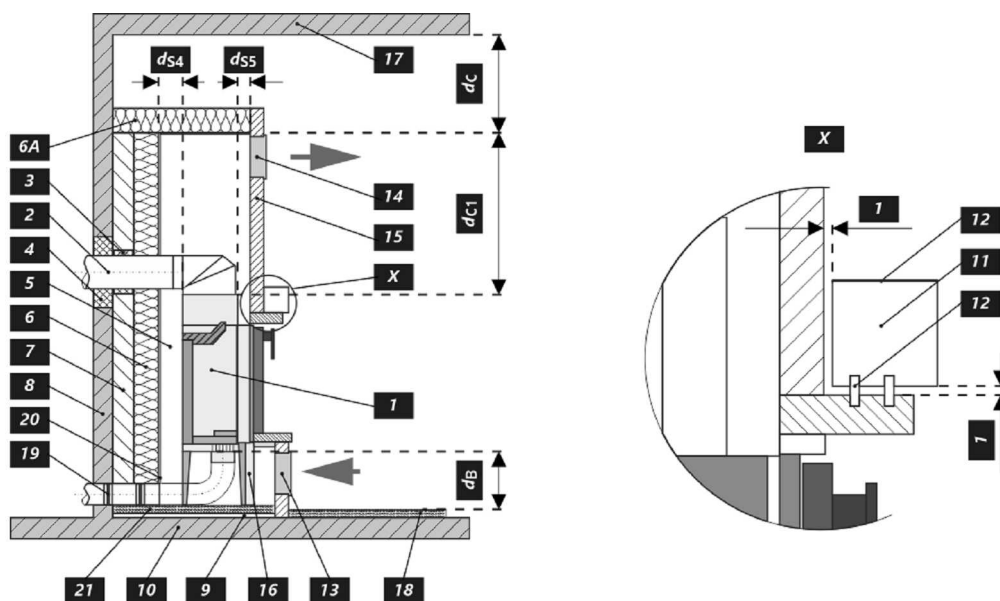

**Ilmoitetut ominaisuudet**

Yhdenmukaistetut tekniset tiedot	EN 13240 ✓ EN 13229	EN 16510 ✓ Ecodesign	✓ DIN+ ✓ BImSchV2	DIBt ✓ 15a B-VG 2015	
Laitteen luokittelu				Type BE	
Energiatehokkuus ( $\eta_{nom}$ )				82,3	%
Energiatehokkuusindeksi				109,4	
Energiamerkintä				A+	
Polttoaine				Puupalot	
Polttopuun pituus				250-400	mm
Keskimääräinen polttoaineenkulutus				2,2	kg/h
Sallittu puumäärä				2,9	kg/h
Puun lisäysväli				1 tunti	
Palamisilman määrä				27,9	m <sup>3</sup> /h
Nimellisteho ( $P_{nom}$ )				7,9	kW
Vesilämmönsiirtimen teho ( $P_{Wnom}$ )				---	kW
Suurin käyttöilpaine ( $p_w$ )				---	bar
Kuivan savukaasun massavirta savukaasupolun laskemiseksi				6,2	g/s
Savukaasun lämpötila ( $T_{nom}$ )				246	°C
Savukaasun keskimääräinen lämpötila supistuksen jälkeen				258	°C
Savuputken veto ( $p_{nom}$ )				12	Pa
Hormin lämpötilaluokka				T400	
Liitäntä yhteiseen hormiin				Kyllä	
Polttoaineen varastointialue				Ei	
Puun maksimaalinen lämpeneminen varastointialueella				---	°C
Dust O <sub>2</sub> = 13 % ( $PM_{nom}$ )				25	mg/Nm <sup>3</sup>
Pölykaasupäästöt (CO savukaasuissa, O <sub>2</sub> = 13 %) ( $CO_{nom}$ )				0,0890 1113	% mg/Nm <sup>3</sup>
OGC O <sub>2</sub> = 13 % ( $OGC_{nom}$ )				52	mg/Nm <sup>3</sup>
NO <sub>x</sub> O <sub>2</sub> = 13 % ( $NO_{xnom}$ )				107	mg/Nm <sup>3</sup>
Automaattinen palamisen säätöyksikkö				---	
Virrankulutus (W)				---	W
Seisovan ilman häviö ( $V_h$ )				---	m <sup>3</sup> <sub>N</sub> /h
Ajoittainen käyttö (INT)   Jatkuva käyttö (CON)				INT	

**Tekniset perustiedot**

Tärkeimmät mitat				1192   808   570	mm
Korkeus (H)   Leveys (W)   Pituus (L)					
Palotilan mitat				472   628   390	mm
Korkeus (H)   Leveys (W)   Pituus (L)					
Fireplace door dimensions				467   664   ---	mm
Korkeus (H)   Leveys (W)   Pituus (L)					
Takimmaisena (sivu-)ulostuloaukon korkeus				---	mm
Vesilämmönsiirtimen tilavuus				---	l
Hormin halkaisija				150-180	mm
Savukanavan liitännän halkaisija ( $D_{out}$ )				180	mm
Ulkoilmaliitännän halkaisija				150	mm
Paino				190	kg
Tuloilmasäleikön pinta-ala				600	cm <sup>2</sup>
Poistoilmasäleikön pinta-ala				800	cm <sup>2</sup>



## Suojaetäisyydet syttyviin materiaaleihin

## Huomautus

Takaosa ( $d_R$ )		800	mm
Etuosa ( $d_P$ )		800	mm
Etuosasta lattiaan ( $d_F$ )		---	mm
Sivu ( $d_S$ )	*	400	mm
Sivu, jossa lasia ( $d_{S1}$ )		---	mm
Sivu – syvennys ( $d_{S2}$ )		---	mm
Sivu – sijainti 45° ( $d_{S3}$ )		---	mm
Sivusäteily ( $d_L$ )		---	mm
Lattiasta ( $d_B$ )		---	mm
Katosta ( $d_C$ )		800	mm
Välimatkta taka- ja sivureunasta eristyksen sisäpuolelle ( $d_{S4}$ )	*	120	mm

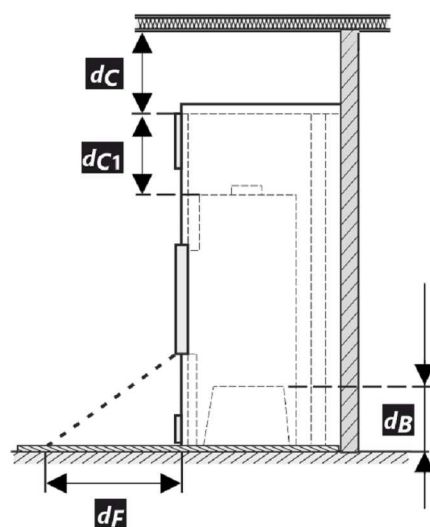
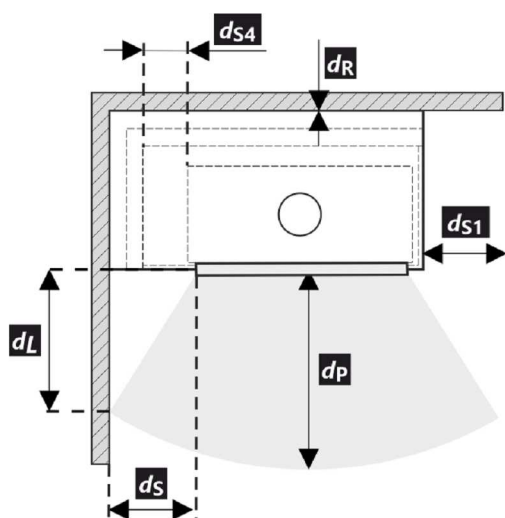

Tuotteen asennuksessa ja käytössä on noudatettava kaikkia paikallisia määräyksiä, mukaan lukien kansallisiin ja eurooppalaisiin standardeihin liittyvät määräykset.

- \* Jos etäisyys oven lasista palavaan sivuseinään on  $d_S < 400$  mm eikä saa olla  $d_{S4} < 120$  mm, tämä seinä on suojattava 40 mm leveällä SILCA 250 -eristelevyllä tai sopivalla korvikkeella.

Selite	Huomautus	Kuvaus	Materiaali	Mitat
1		Laite	230F 0000 001	
2		Savukaasun ulostulo	metalli	DN150-180
3		Savukaasuliitännän eristys		
4		Mineraalieristys		
5		Konvektioilmatila laitteen ympärillä		
6		Seinien suojaeristys	SILCA 250	2x50 mm
6A		Katon suojaeristys	SILCA 250	80 mm
7		Suojaseinä	ontto poltettu tiili	100 mm
8		Palava seinä		
9		Betonilaatta		
10		Palava lattia		

11	Peitelevy		
12	Levy, jossa ilmanvaihtoaukko		
13	Konvektioilman tulo		600 cm <sup>2</sup>
14	Konvektioilman lähtö		800 cm <sup>2</sup>
15	Eristys	SILCA 250	40 mm
16	Tukirunko		
17	Palava katto		
18	Suojaava eristyslevy palavia lattiaita varten	SILCA 250	40 mm
19	Ilmansäädin		
20	Peltikansi, jos käytetään mineraalivillaa		
21	Tarvittaessa lattian suojalevy laitteen alle		
<b>d<sub>c</sub></b>	Poistoilmaventtiilin yläreunasta palavaan kattoon asti		800 mm
<b>d<sub>c1</sub></b>	– Takan yläreunasta kattoeristeen alareunaan		300 mm
	– Jos lämmönsiirrin on asennettu, lämmönsiirtimen yläreunasta kattoeristeen alareunaan		--- mm
<b>d<sub>s4</sub></b>	* Taka- ja sivureunasta eristyksen sisäpuolelle		120 mm
<b>d<sub>s5</sub></b>	Takan etureunasta eristyksen sisäreunaan		10 mm
<b>d<sub>B</sub></b>	Takan alareunasta palamattomaan lattiaan		--- mm

**Varoitus:** Palonsuoja- / eristelevyt SILCA 250 (SILCA® 250SB, paksuus 40 mm) voidaan korvata sopivalla syttymättömällä materiaalilla, jonka lämmönjohtavuus  $\leq 1,1 \text{ W} \cdot \text{m}^{-1} \cdot \text{K}^{-1}$  ( $\lambda$ ).

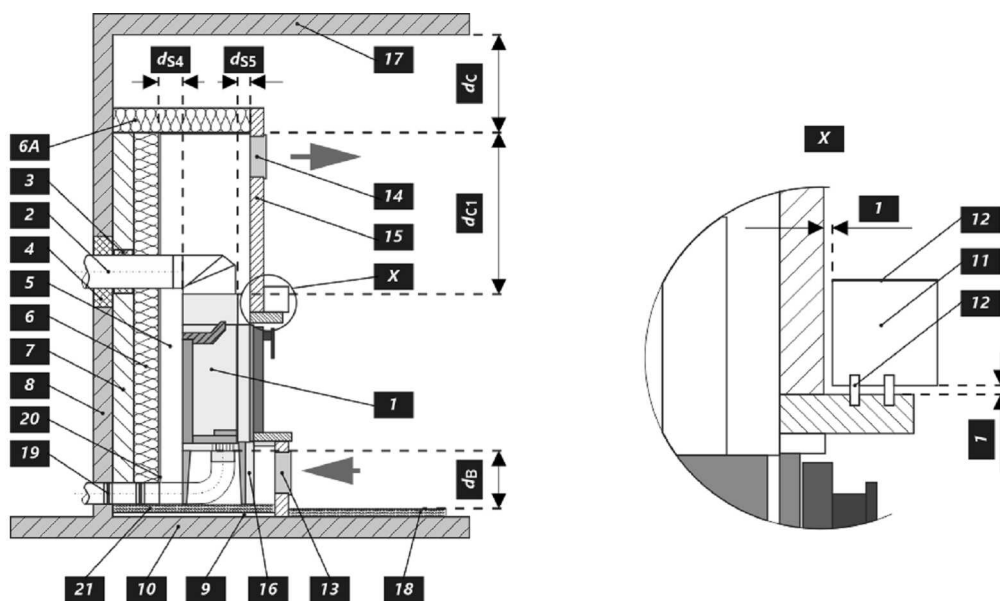

**Deklareeritud omadused**

Harmoneeritud tehniline spetsifikatsioon	EN 13240 ✓ EN 13229	EN 16510 ✓ Ecodesign	✓ DIN+ ✓ BImSchV2	DIBt ✓ 15a B-VG 2015	
Seadme klassifikatsioon				Type BE	
Energiatõhusus ( $\eta_{nom}$ )				82,3	%
Energiatõhususe indeks				109,4	
Energiamärgis				A+	
Küttematerjal				Puuhalud	
Küttematerjali pikkus				250-400	mm
Keskmine küttematerjali tarve				2,2	kg/h
Lubatud küttematerjali hulk				2,9	kg/h
Küttematerjali lisamise intervall				1 tund	
Põlemisõhu hulk				27,9	m <sup>3</sup> /h
Nimivõimsus ( $P_{nom}$ )				7,9	kW
Soojusvaheti võimsus ( $P_{Wnom}$ )				---	kW
Maksimaalne tööülerõhk ( $p_w$ )				---	bar
Suitsugaaside kuivmass suitsugaaside teekonna arvutamiseks				6,2	g/s
Suitsugaasi temperatuur ( $T_{nom}$ )				246	°C
Suitsugaasi keskmine temperatuuri pärast kraed				258	°C
Suitsutoru tõmme ( $p_{nom}$ )				12	Pa
Korstna temperatuuriklass				T400	
Ühendus üldkorstnaga				Jah	
Küttematerjali ladustamine puude säilitusalal				Ei	
Puidu maksimaalne soojenemine säilitusalal				---	°C
Tolm O <sub>2</sub> = 13 % ( $PM_{nom}$ )				25	mg/Nm <sup>3</sup>
Põlemisgaaside emissioon suitsugaaside CO kui O <sub>2</sub> = 13 % ( $CO_{nom}$ )				0,0890 1113	% mg/Nm <sup>3</sup>
OGC O <sub>2</sub> = 13 % ( $OGC_{nom}$ )				52	mg/Nm <sup>3</sup>
NO <sub>x</sub> O <sub>2</sub> = 13 % ( $NO_{xnom}$ )				107	mg/Nm <sup>3</sup>
Automaatne põlemise reguleerimisseade				---	
Energiatarve ( $W$ )				---	W
Seisva õhu kadu ( $V_n$ )				---	m <sup>3</sup> <sub>N</sub> /h
Vahelduv töö (INT) / Pidev töö (CON)				INT	

**Tehnilised põhiandmed**

Põhimõõtmed Kõrgus (H)   Laius (W)   Pikkus (L)	1192   808   570	mm
Põlemiskambri mõõdud Kõrgus (H)   Laius (W)   Pikkus (L)	472   628   390	mm
Kolde ukse mõõdud Kõrgus (H)   Laius (W)   Pikkus (L)	467   664   ---	mm
Tagumise (külgmise) väljalaskeava telje kõrgus	---	mm
Sooja vee soojusvaheti maht	---	l
Suitsutoru diameeter	150-180	mm
Suitsutoru ava diameeter ( $D_{out}$ )	180	mm
Välisõhu ühenduse diameeter	150	mm
Kaal	190	kg
Sisselaske ventilatsioonivõre	600	cm <sup>2</sup>
Väljalaske ventilatsioonivõre	800	cm <sup>2</sup>

Kaugus põlevatest materjalidest	Märkus		
Tagaosa ( $d_R$ )		800	mm
Esiosa ( $d_P$ )		800	mm
Esiosast pörandani ( $d_F$ )		---	mm
Külg ( $d_S$ )	*	400	mm
Klaasiga külg ( $d_{S1}$ )		---	mm
Külg – nišš ( $d_{S2}$ )		---	mm
Külg – asend $45^\circ$ ( $d_{S3}$ )		---	mm
Kiirgus külje suunas ( $d_L$ )		---	mm
Pörandast ( $d_B$ )		---	mm
Laest ( $d_C$ )		800	mm
Kaminasüdamiku tagumisest ja külgmisest nurgast isolatsiooni sisemuseni ( $d_{S4}$ )	*	120	mm

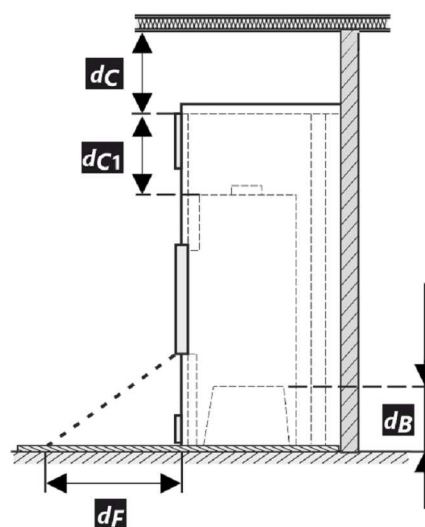
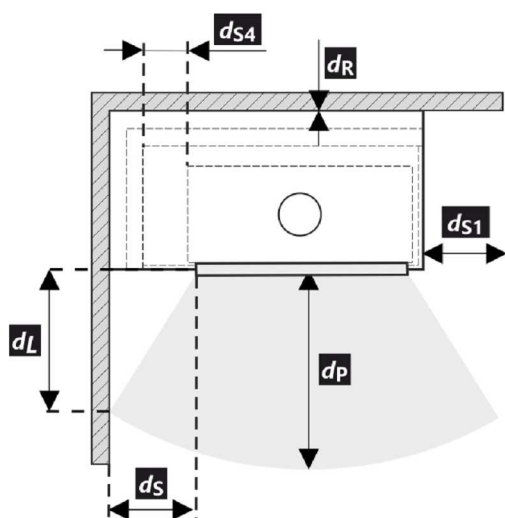

Toote paigaldamise ja kasutamise ajal tuleb järgida kõiki kohalikke määrusi, kaasa arvatud siseriiklikest ja Euroopa standarditest tulenevad määrad.

- \* Kui ukseklaasi kaugus süttivast materjalist seinast on  $d_S < 400$  mm, ent kui see ei tohiks olla  $d_{S4} < 120$  mm, siis tuleb see sein katta 40 mm laiuse SILCA 250 isolatsiooniplaadi või muu võrdväärse materjaliga.

Nr	Märkus	Kirjeldus	Materjal	Möödud
1		Seade	230F 0000 001	
2		Suitsugaasi väljalasketoru	metall	DN150-180
3		Suitsugaasi ühenduse soojustus		
4		Mineraalvill		
5		Konvektsiooni õhuruum seadme ümber		
6		Seinte kaitsekiht	SILCA 250	2x50 mm
6A		Seinte kaitsekiht	SILCA 250	80 mm
7		Kaitsesein	põletatud õonestellis	100 mm
8		Põlev seinamaterjal		
9		Betoonplaat		
10		Põlev pörandmaterjal		

11	Dekoratiivne / muustriline tala		
12	Ventilatsiooni õhupiluga tala		
13	Konvektsiooni sissepuhkevõre		600 cm <sup>2</sup>
14	Konvektsiooni väljapuhkevõre		800 cm <sup>2</sup>
15	Vooder	SILCA 250	40 mm
16	Tugiraam		
17	Põlev laematerjal		
18	Põlevast materjalist põrandat kaitsev soojustusplaat	SILCA 250	40 mm
19	Põlemisõhu reguleerimine		
20	Metallkate, kui kasutatakse mineraalvilla		
21	Vajdusel seadmealuse põrandat kaitseplaat		
<b>d<sub>c</sub></b>	Väljatõmbeventilatsiooni otsast põleva laematerjalini		800 mm
<b>d<sub>c1</sub></b>	– Kaminasüdamiku tipust lae soojustuse alumise pooleni – Kui on paigaldatud soojusvaheti, siis soojusvaheti ülemisest nurgast lae soojustuse alumise pooleni		300 mm --- mm
<b>d<sub>s4</sub></b>	*	Kaminasüdamiku tagumisest ja külgmisest nurgast soojustuse sisepinnani	120 mm
<b>d<sub>s5</sub></b>		Kaminasüdamiku eesmisest nurgast soojustuse sisepinnani	10 mm
<b>d<sub>B</sub></b>		Kaminsaüdamiku põhjast tulekindla põrandani	--- mm

**Hoiatus:** Tuletõkke- / isolatsiooniplaadid SILCA 250 (SILCA® 250SB, paksus 40 mm) võib asendada sobiva mittesüttiva materjaliga, mille soojusjuhtivus on  $\leq 1,1 \text{ W}\cdot\text{m}^{-1}\cdot\text{K}^{-1}$  ( $\lambda$ ).

