

- (A) Litinový odvod kouře / Cast iron spigot / Der gusseiserne Rauchabgang
- (B) Centralní privod vzduchu / Central air inlet / Zentralluftzufuhr
- (C) Primární a sekundární vzduch / Primary and secondary air / Primärluft und Sekundärluft

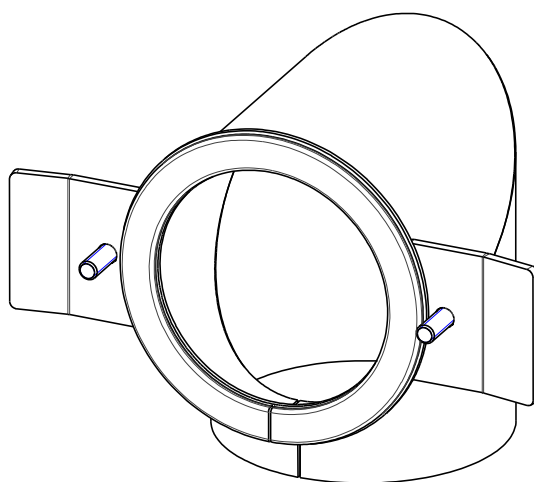

- (A) Litinový odvod kouře / Cast iron spigot / Der gusseiserne Rauchabgang
 (B) Centralní přívod vzduchu / Central air inlet / Zentralluftzufuhr
 (C) Primární a sekundární vzduch / Primary and secondary air / Primärluft und Sekundärluft

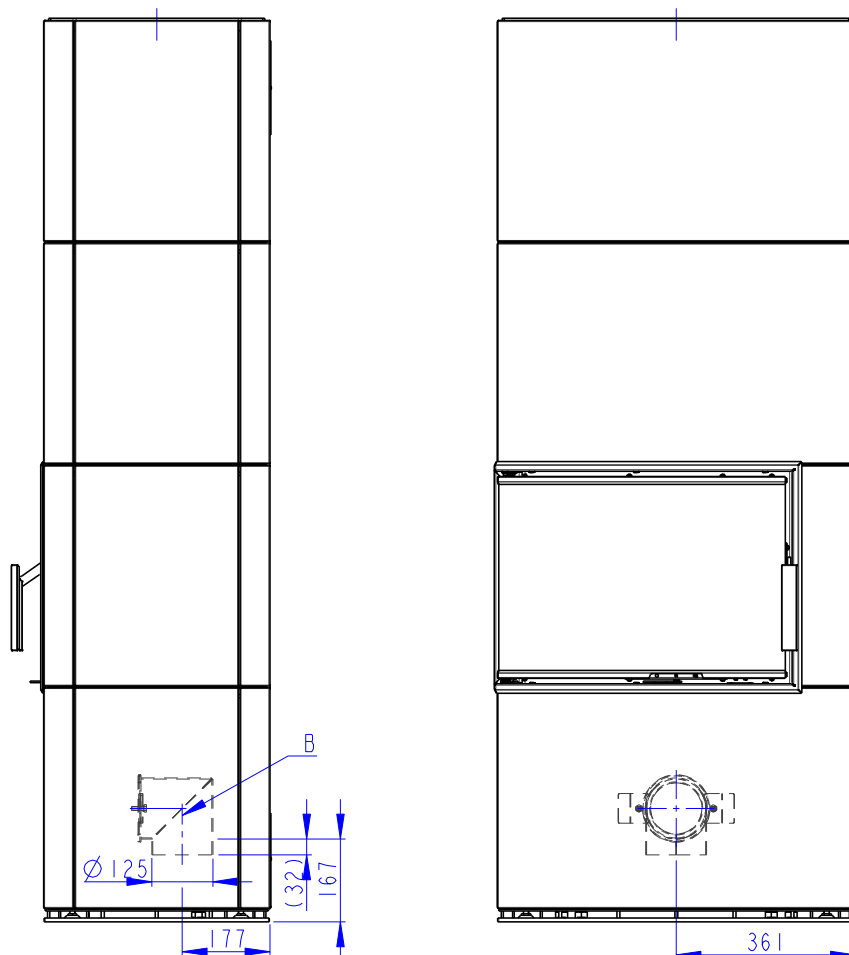
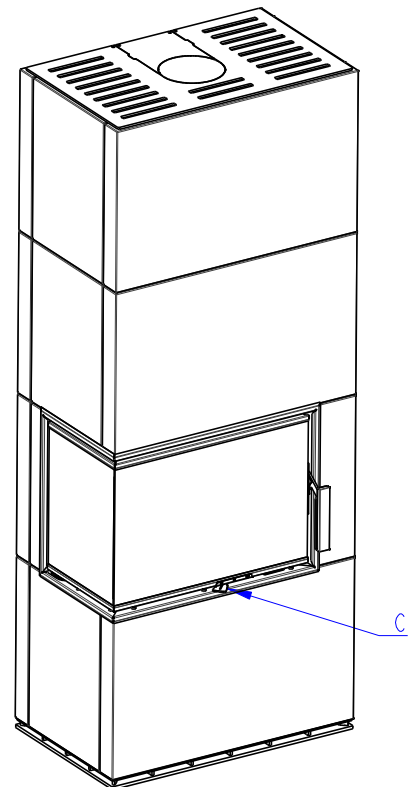
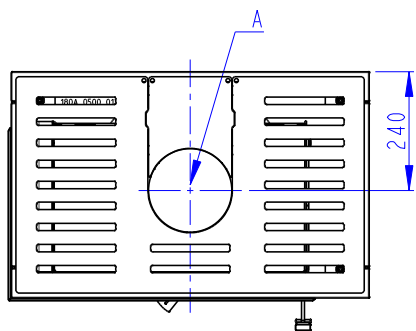
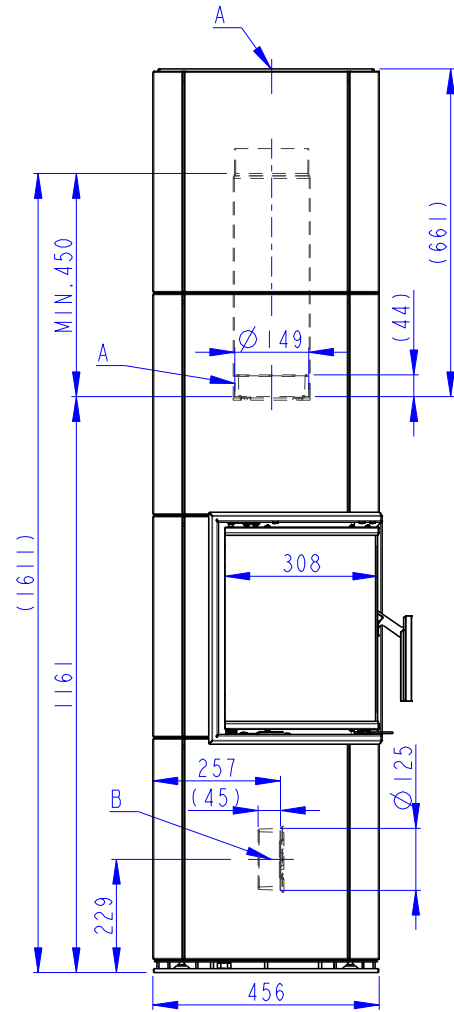
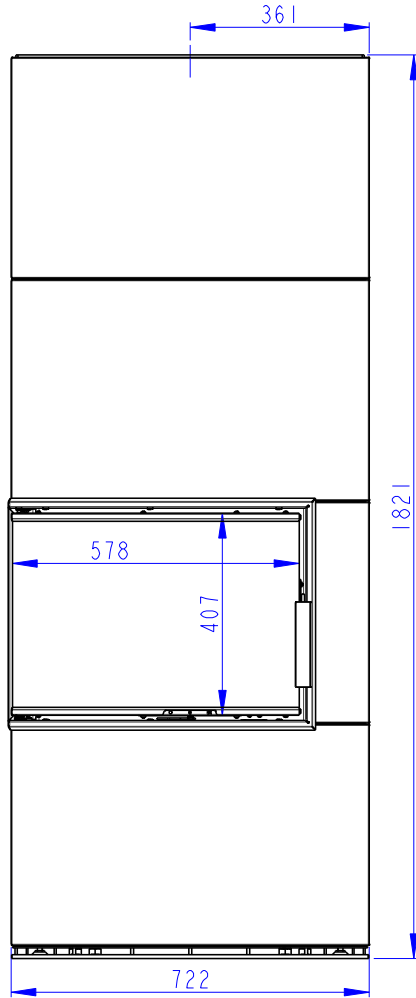

- (A) Litinový odvod kouře / Cast iron spigot / Der gusseiserne Rauchabgang
- (B) Centralní privod vzduchu / Central air inlet / Zentralluftzufuhr
- (C) Primární a sekundární vzduch / Primary and secondary air / Primärluft und Sekundärluft

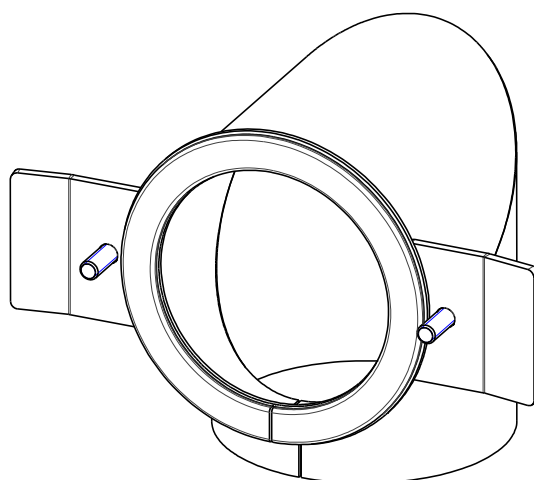
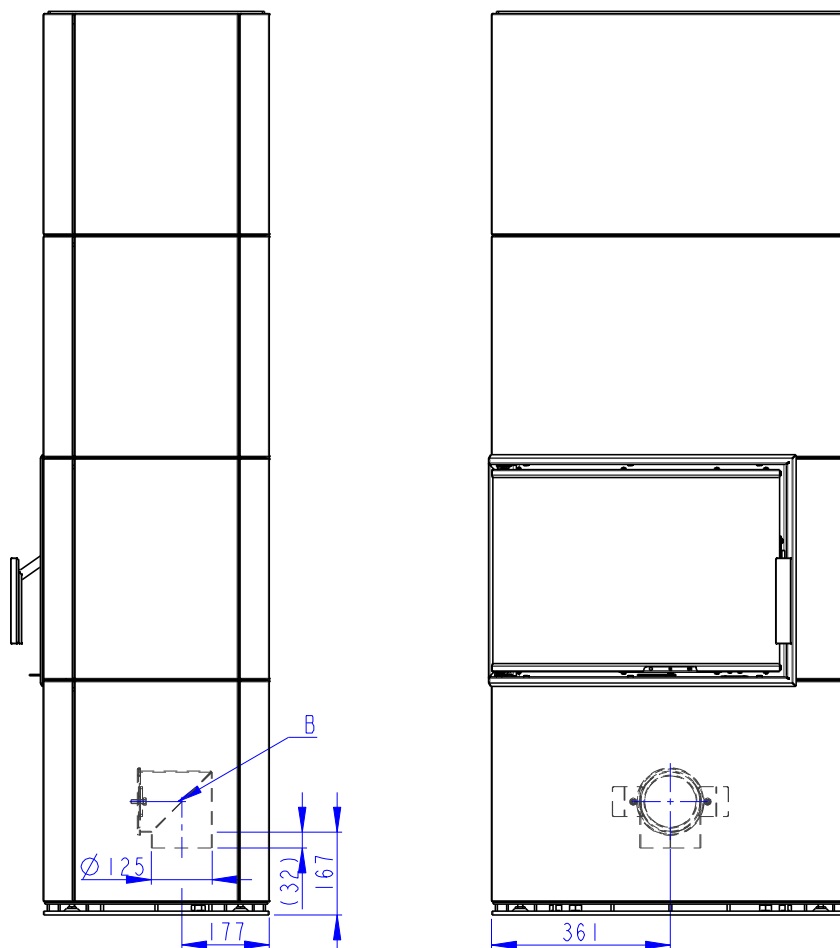

- (A) Litinový odvod kouře / Cast iron spigot / Der gusseiserne Rauchabgang
 (B) Centralní privod vzduchu / Central air inlet / Zentralluftzufuhr
 (C) Primární a sekundární vzduch / Primary and secondary air / Primärluft und Sekundärluft