

Rozměry v mm  
Dimensions in mm  
Maße in mm

Heat L 2g S 50.44.33.13(23)

100kg

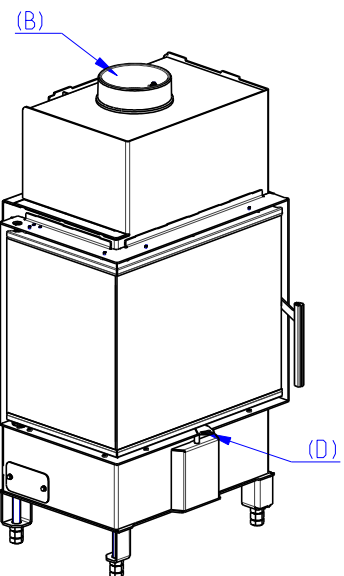
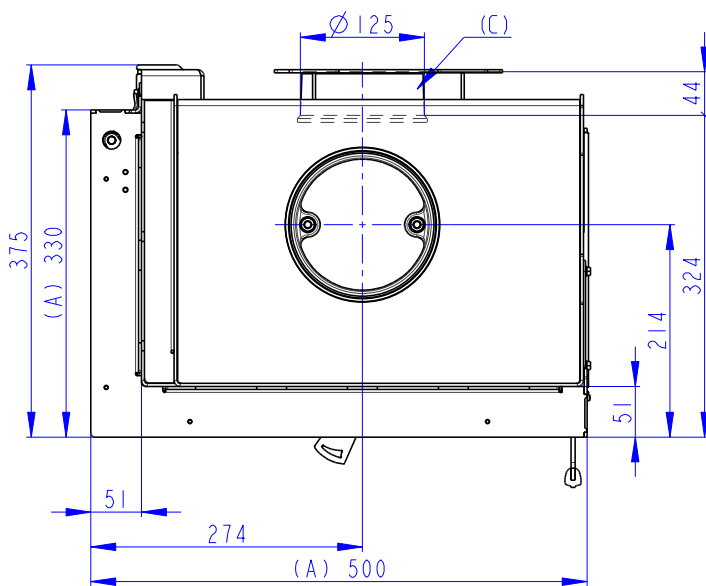
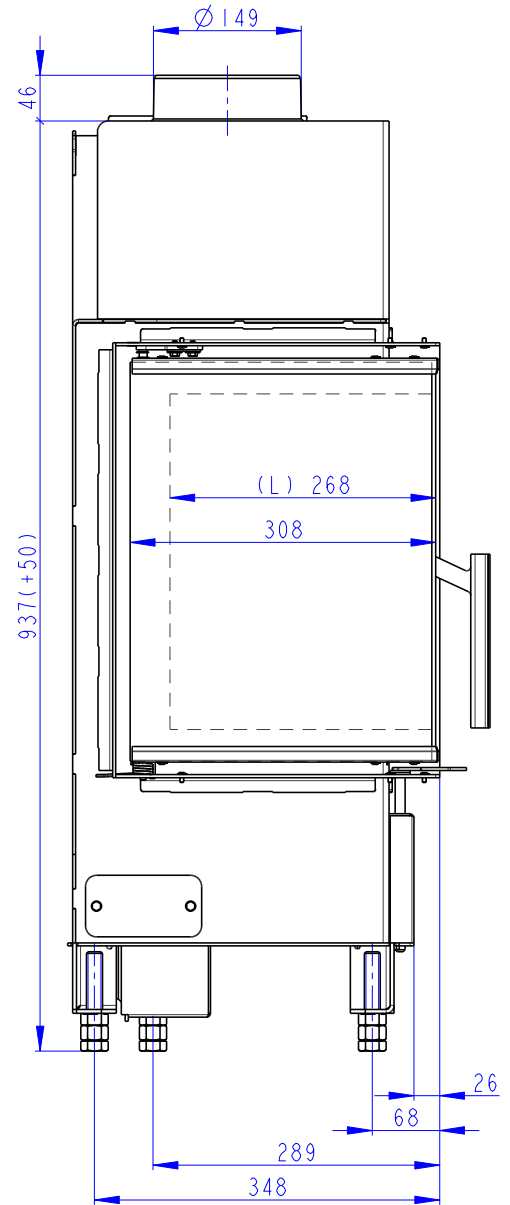
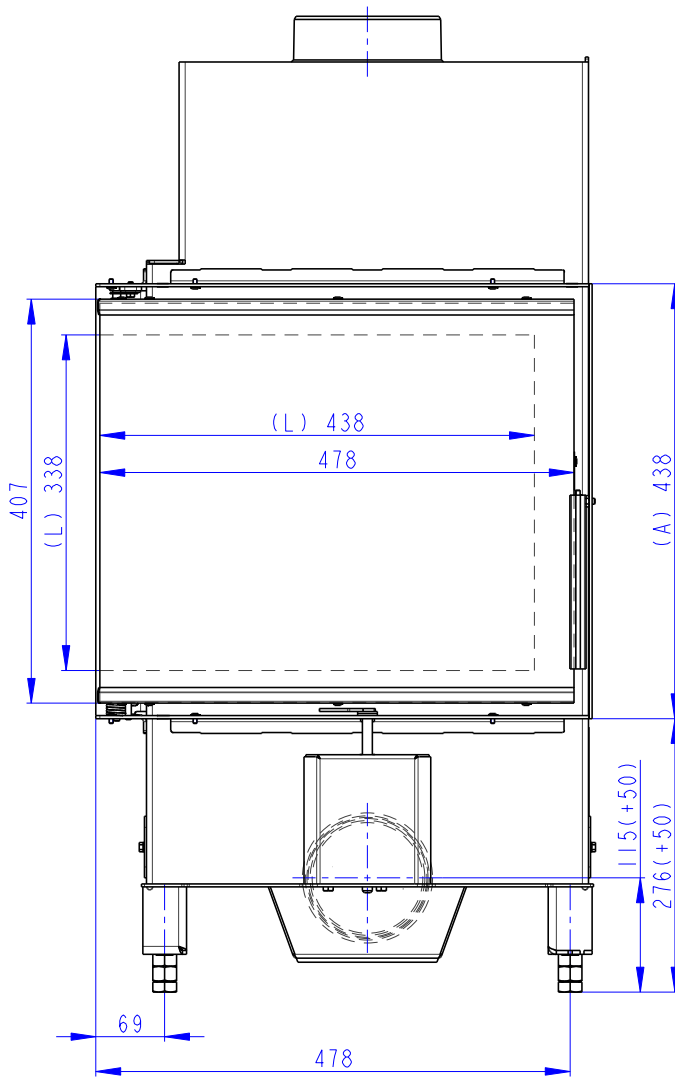

- (A) Zastavbovy rozmer / In-built dimension / Baumaße  
 (B) Litinový odvod kouře / Cast iron spigot / Der gusseiserne Rauchabgang  
 (C) Centrální privod vzduchu / Central air inlet / Zentralluftzufuhr  
 (D) Primární a sekundární vzduch / Primary and secondary air / Primärluft und Sekundärluft  
 (L) Volná plocha prosklení / Free glass area / Freie Glassichtfläche

Rozměry v mm  
Dimensions in mm  
Maße in mm

Heat L 2g S 50.44.33.13(23)  
+ H2 AIRBOX 01  
100kg

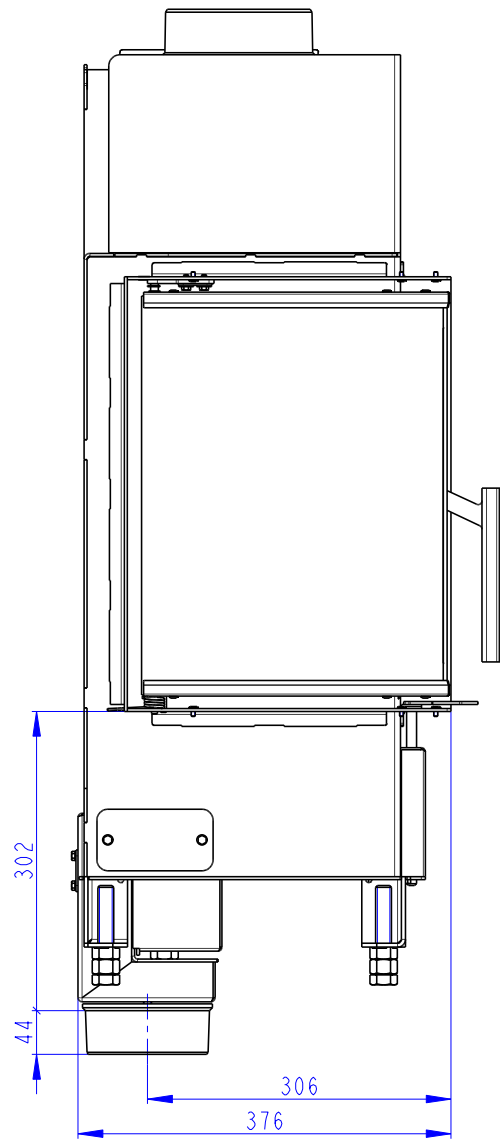
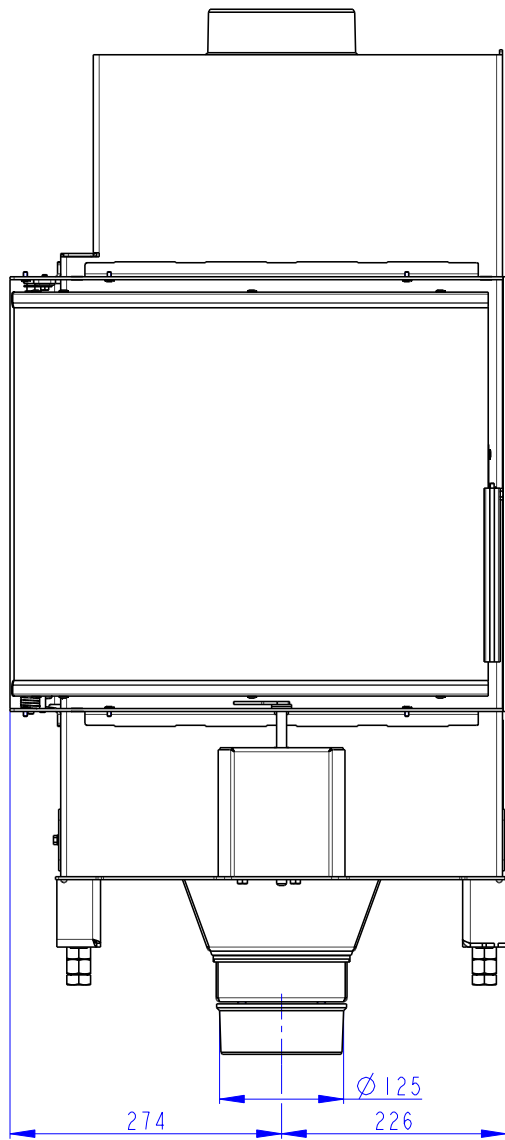

Rozmery v mm  
Dimensions in mm  
Maße in mm

Heat L 2g S 50.44.33.13(23)  
+ AKKUM KV 02  
190kg

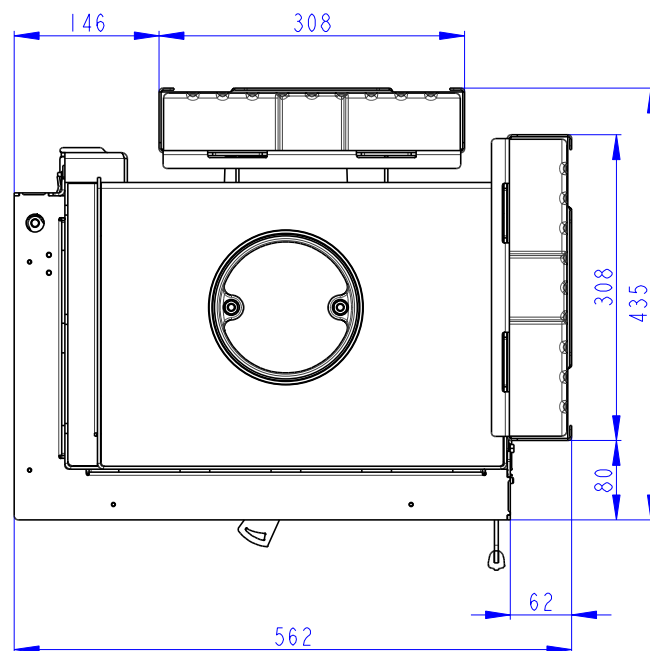
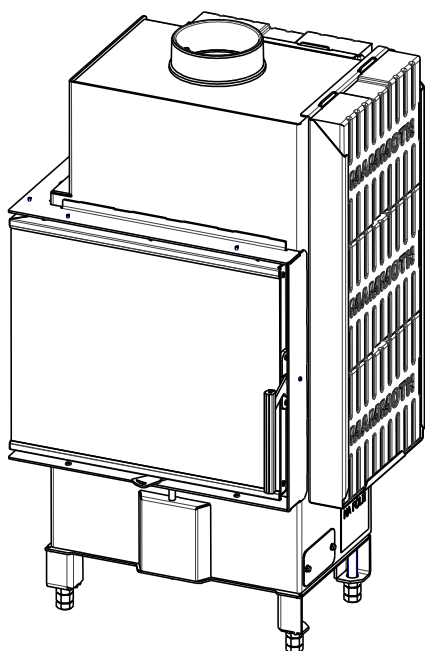
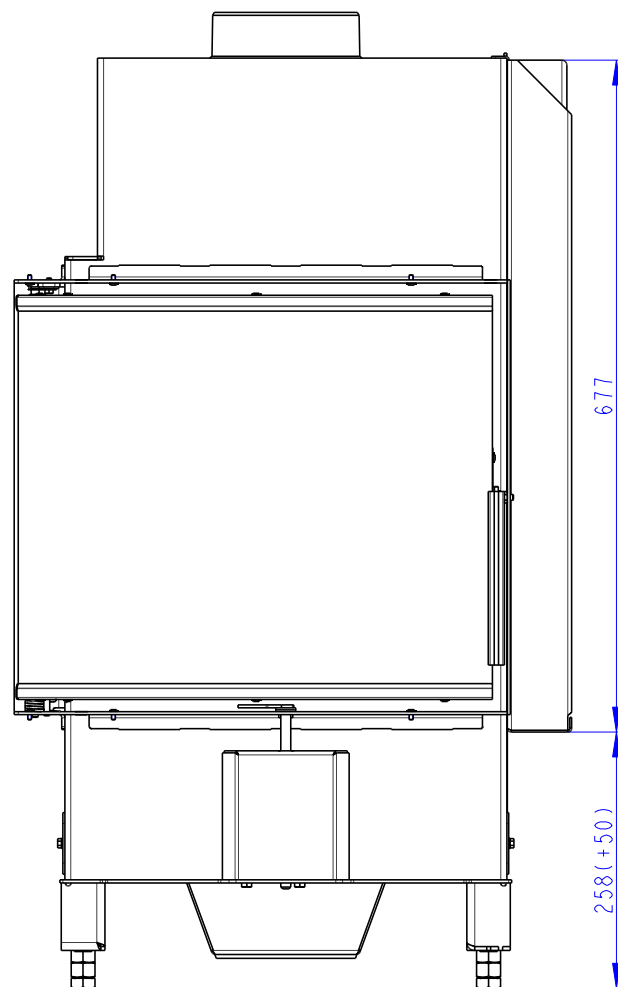
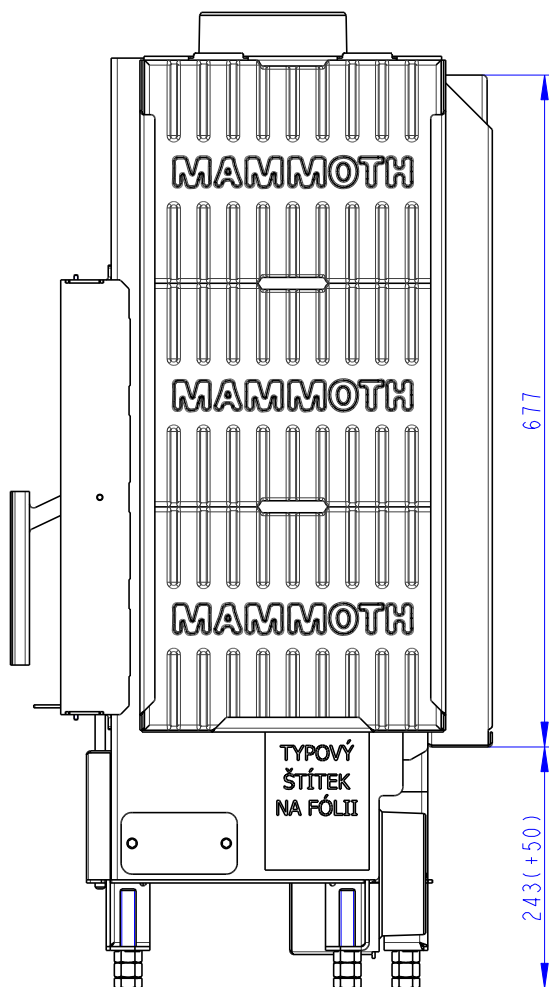

Rozmery v mm  
Dimensions in mm  
Maße in mm

Heat L 2g S 50.44.33.13(23)  
+ AKKUM KV 03  
170kg

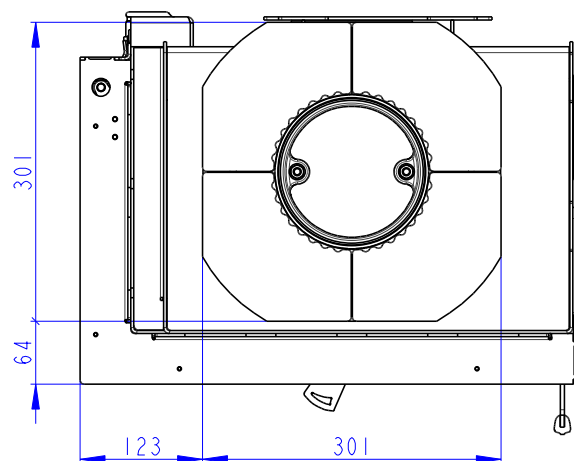
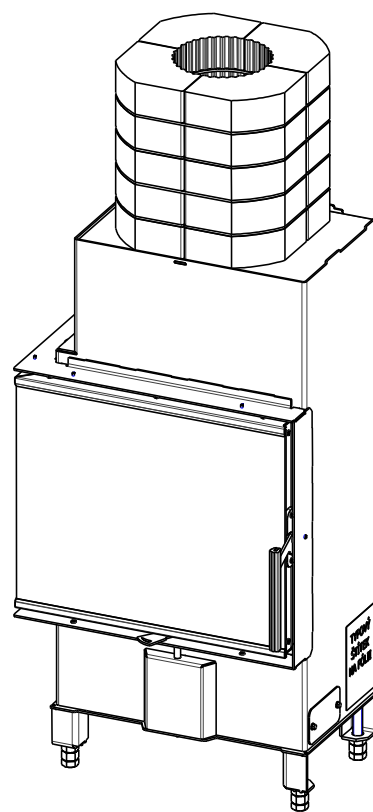
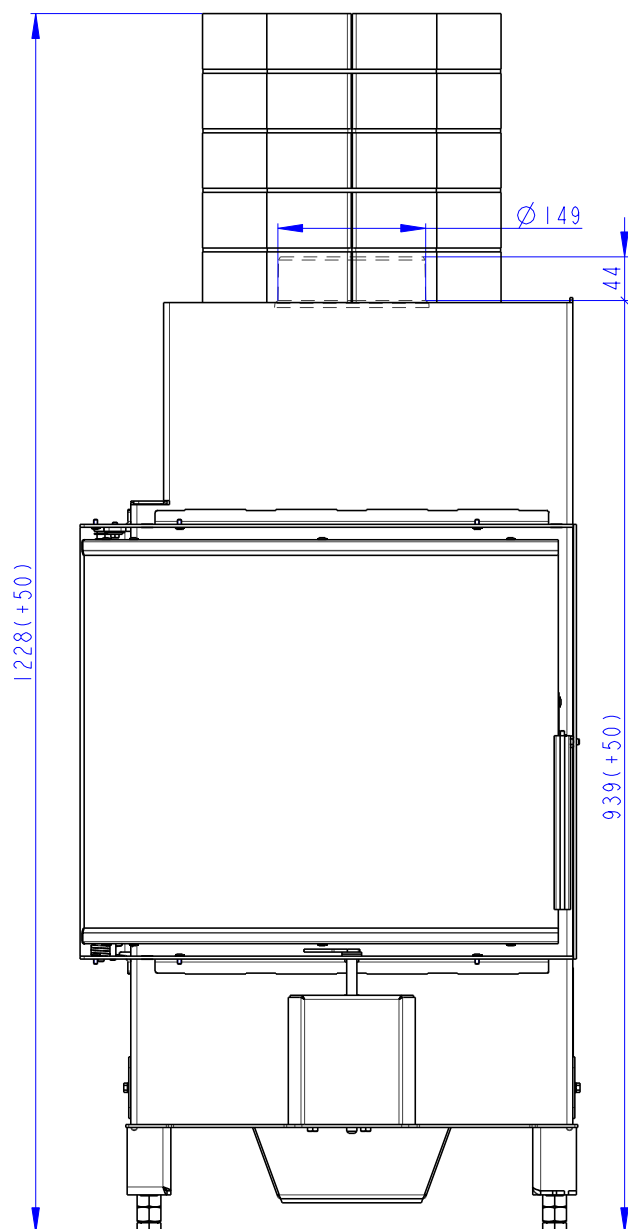

Rozměry v mm  
Dimensions in mm  
Maße in mm

Heat L 2g S 50.44.33.13(23)  
+ HR2SV RAM04  
100kg

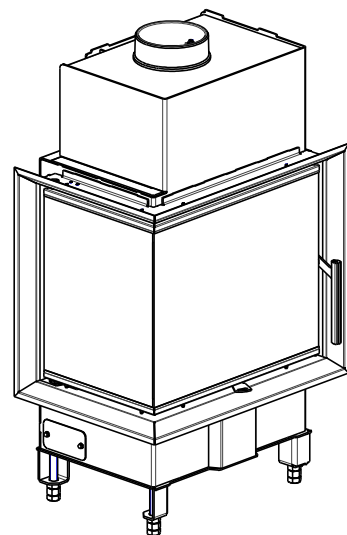
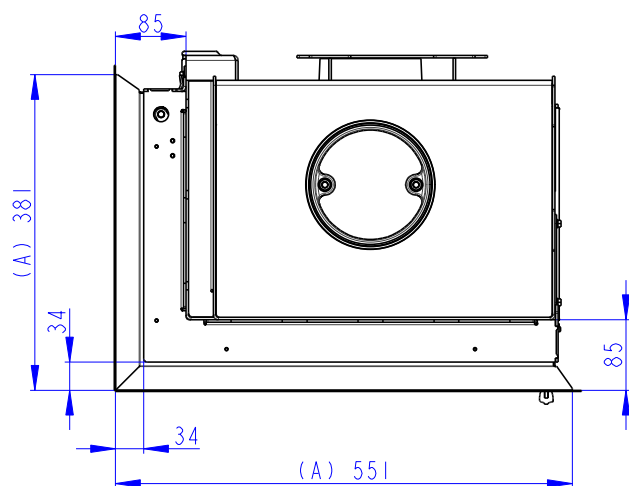
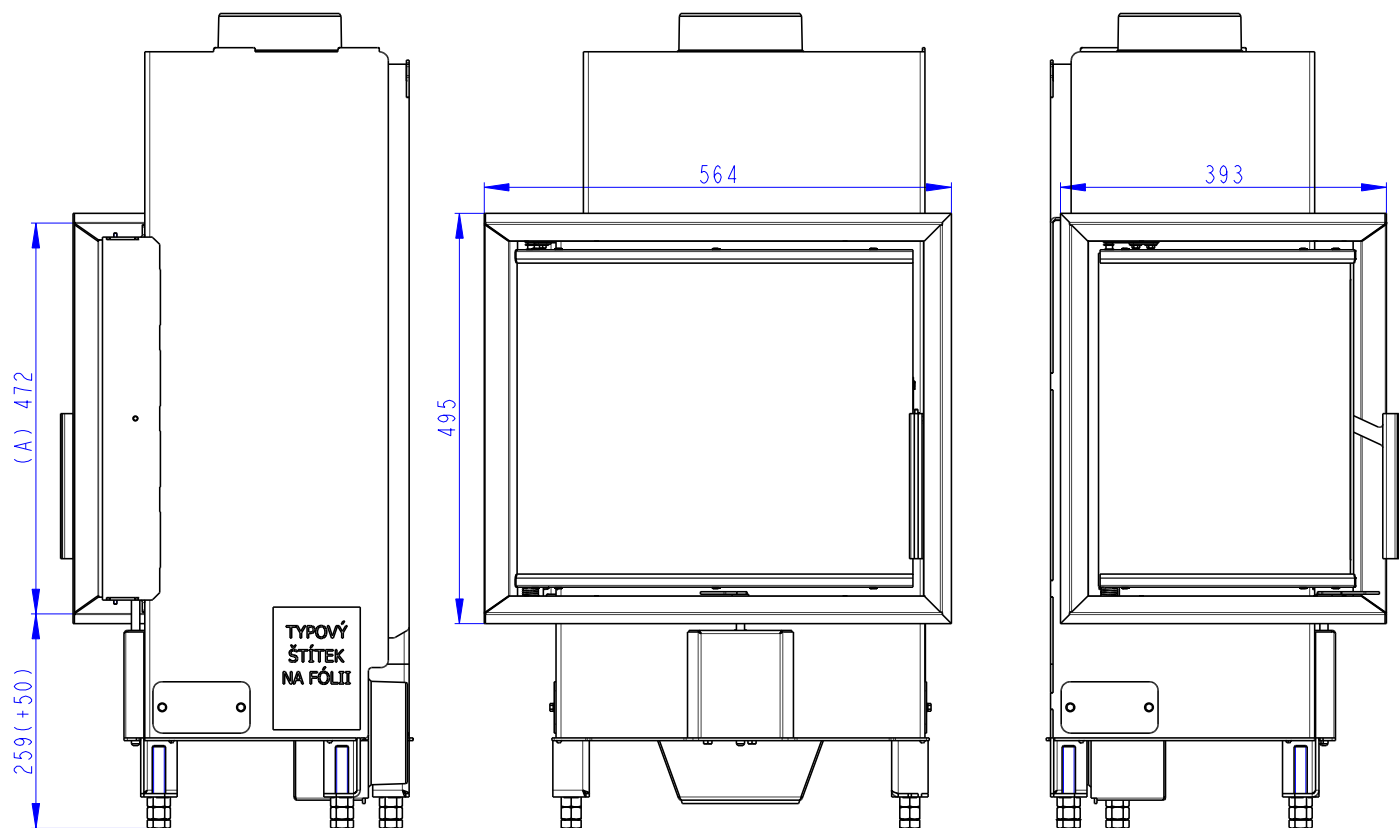

- (A) Zastavbovy rozmer / In-built dimension / Baumaße
- (B) Litinový odvod kouře / Cast iron spigot / Der gusseiserne Rauchabgang
- (C) Centrální privod vzduchu / Central air inlet / Zentralluftzufuhr
- (D) Primární a sekundární vzduch / Primary and secondary air / Primärluft und Sekundärluft
- (L) Volná plocha prosklení / Free glass area / Freie Glassichtfläche

Rozměry v mm  
Dimensions in mm  
Maße in mm

Heat L 2g S 50.44.33.13(23)  
+ HR2SV RAM06  
100kg

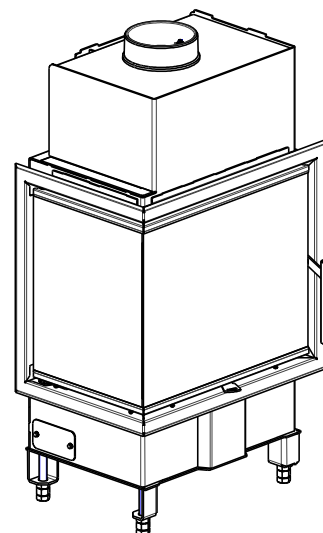
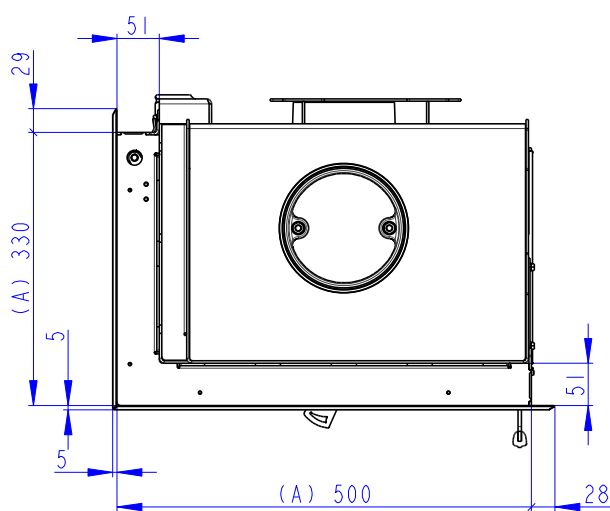
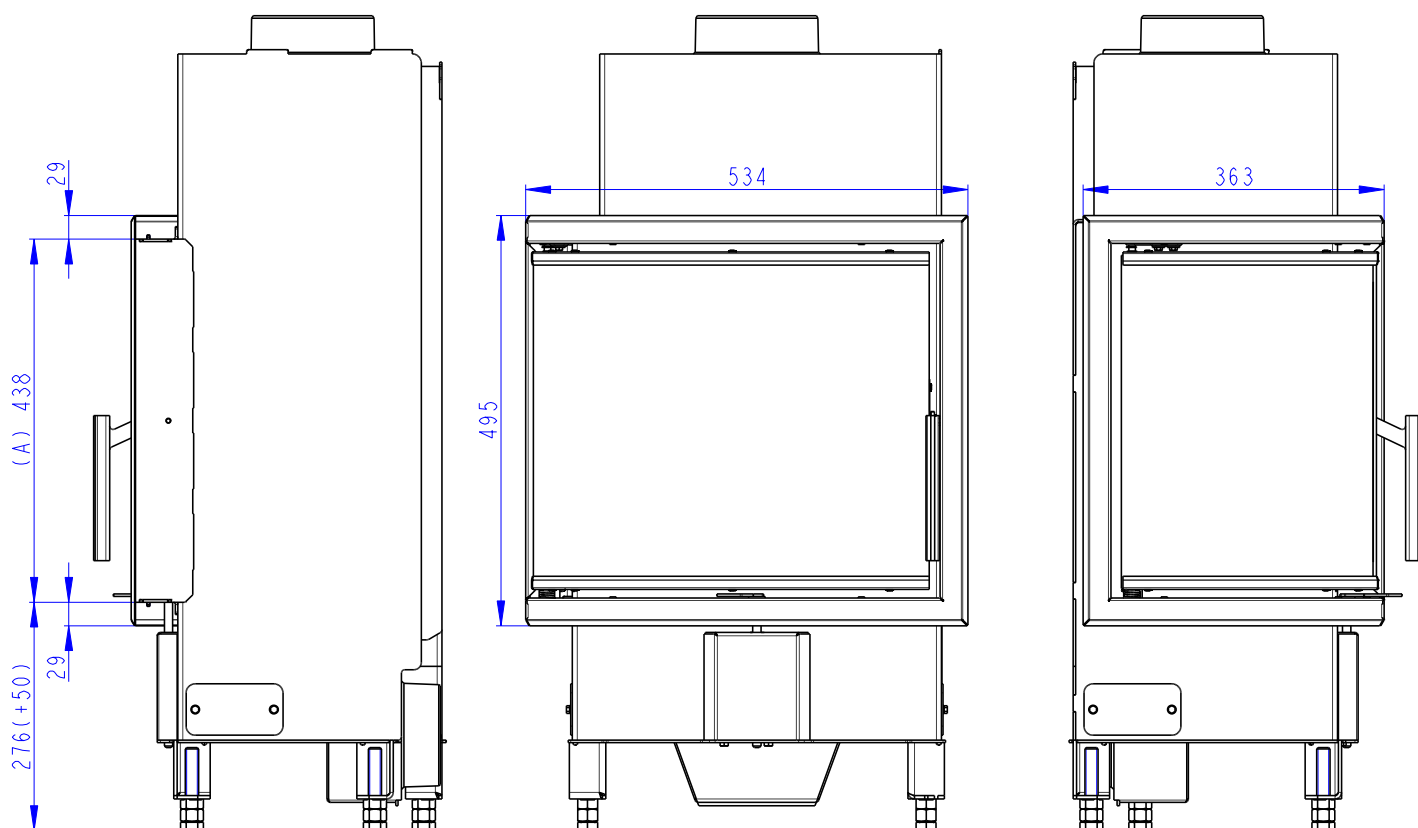

- (A) Zastavbovy rozmer / In-built dimension / Baumaße  
 (B) Litinový odvod kouře / Cast iron spigot / Der gusseiserne Rauchabgang  
 (C) Centralní přívod vzduchu / Central air inlet / Zentralluftzufuhr  
 (D) Primární a sekundární vzduch / Primary and secondary air / Primärluft und Sekundärluft  
 (L) Volná plocha prosklení / Free glass area / Freie Glassichtfläche

Rozměry v mm  
Dimensions in mm  
Maße in mm

Heat L 2g S 50.44.33.13(23)  
100kg

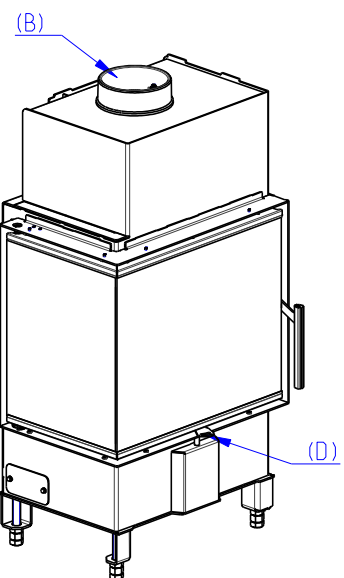
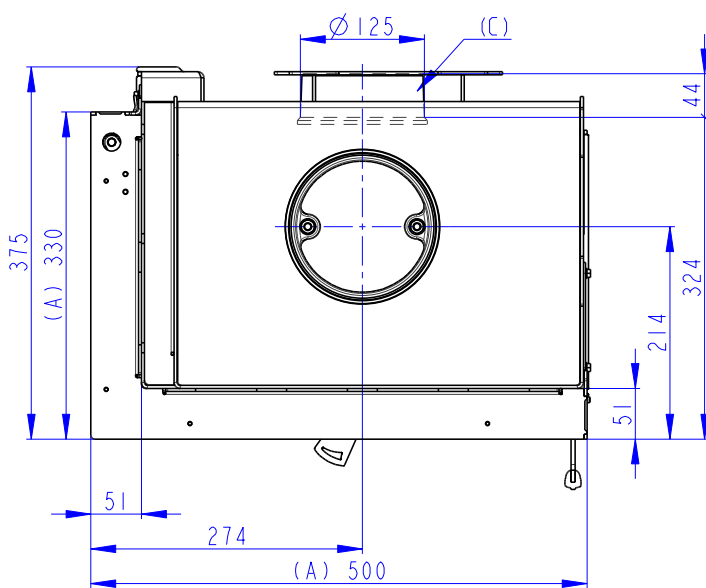
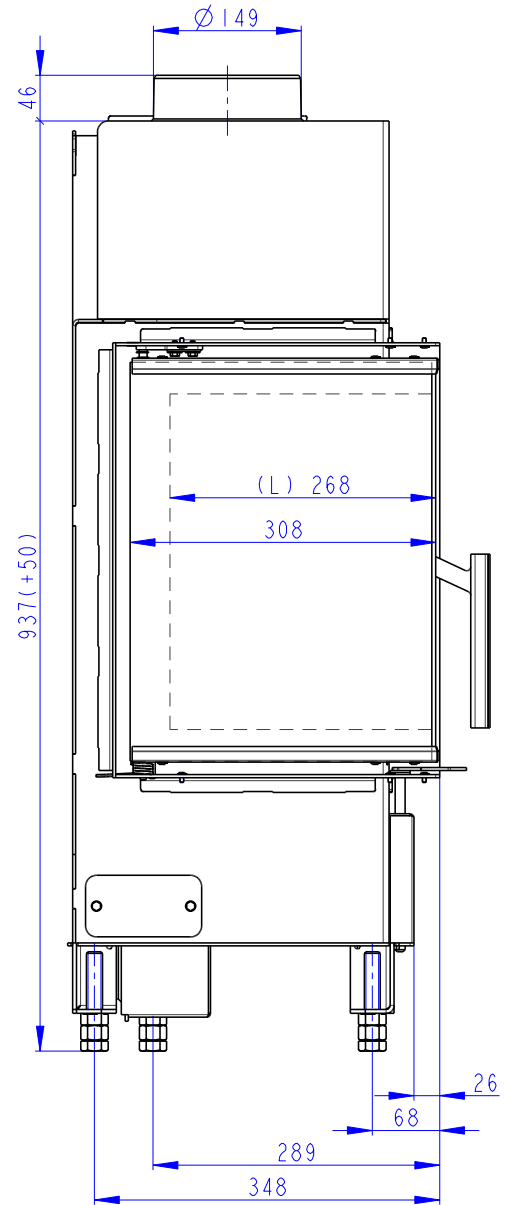
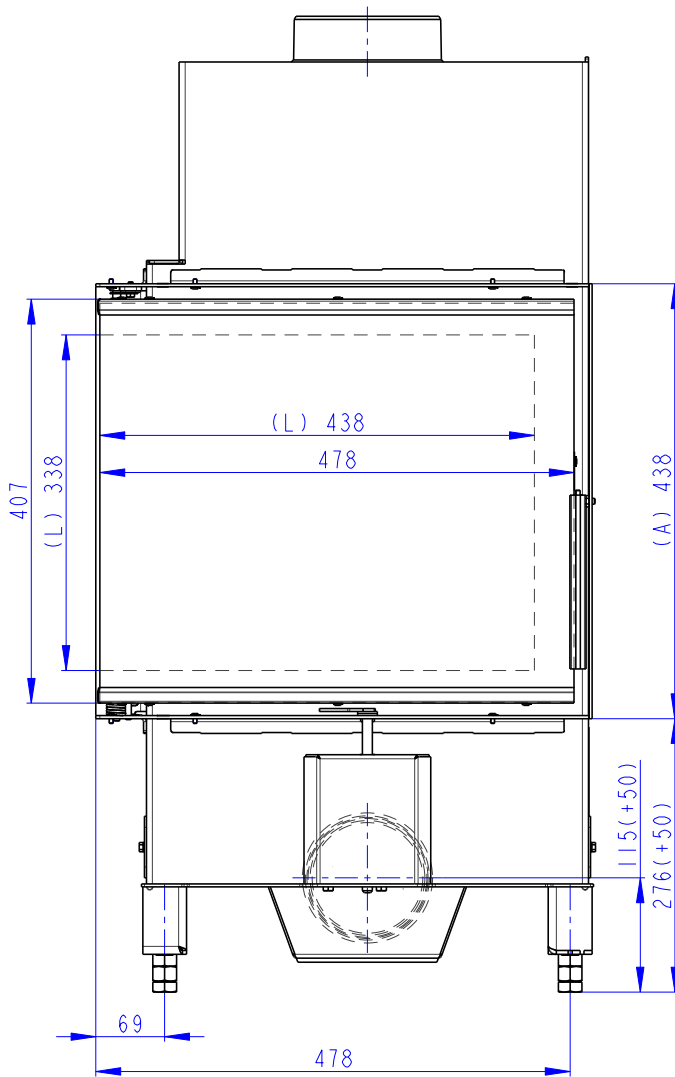

- (A) Zastavbovy rozmer / In-built dimension / Baumaße  
 (B) Litinový odvod kouře / Cast iron spigot / Der gusseiserne Rauchabgang  
 (C) Centrální privod vzduchu / Central air inlet / Zentralluftzufuhr  
 (D) Primární a sekundární vzduch / Primary and secondary air / Primärluft und Sekundärluft  
 (L) Volná plocha prosklení / Free glass area / Freie Glassichtfläche

Rozměry v mm  
Dimensions in mm  
Maße in mm

Heat L 2g S 50.44.33.13(23)  
+ H2 AIRBOX 01  
100kg

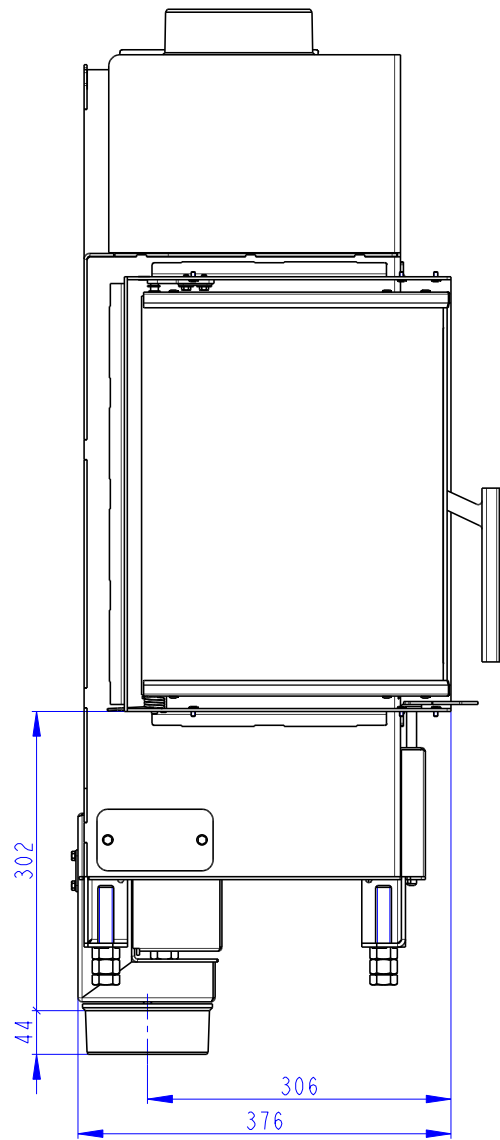
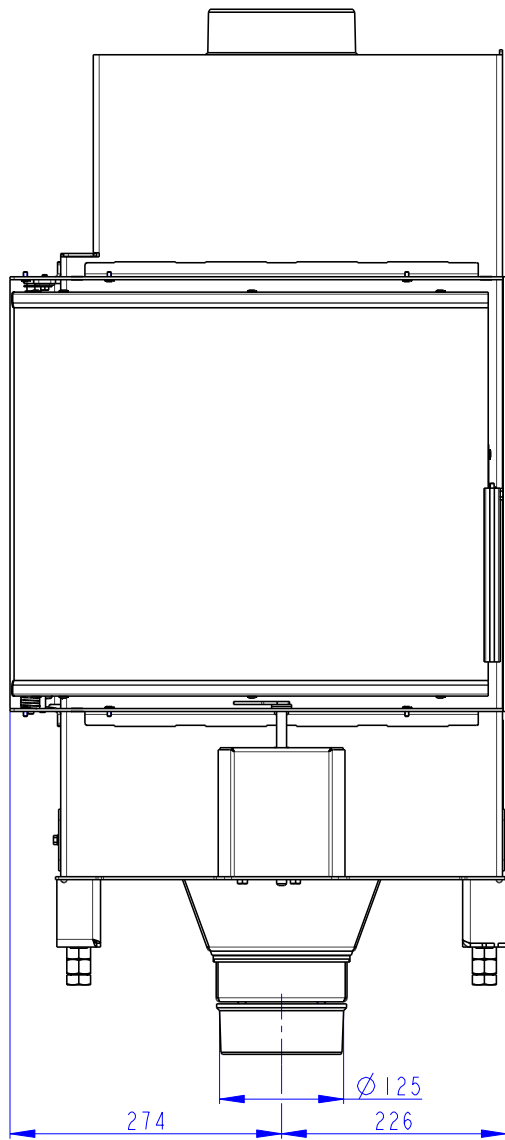



Rožmery v mm  
Dimensions in mm  
Maße in mm

Heat L 2g S 50.44.33.13(23)  
+ AKKUM KV 02  
190kg

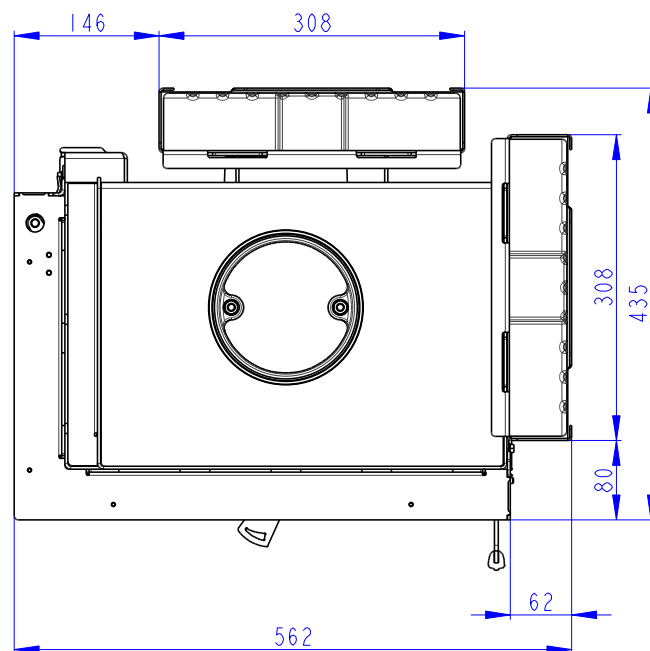
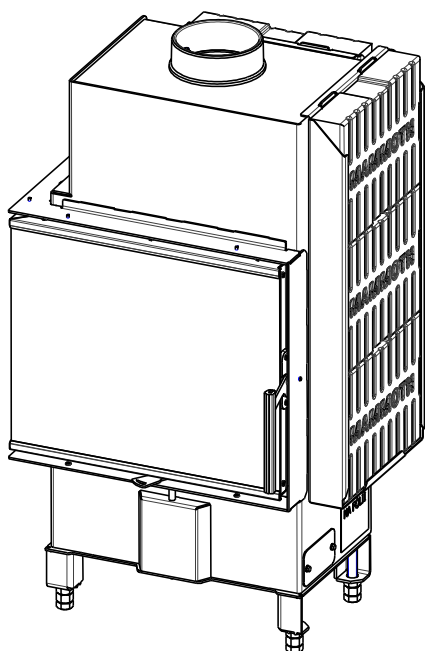
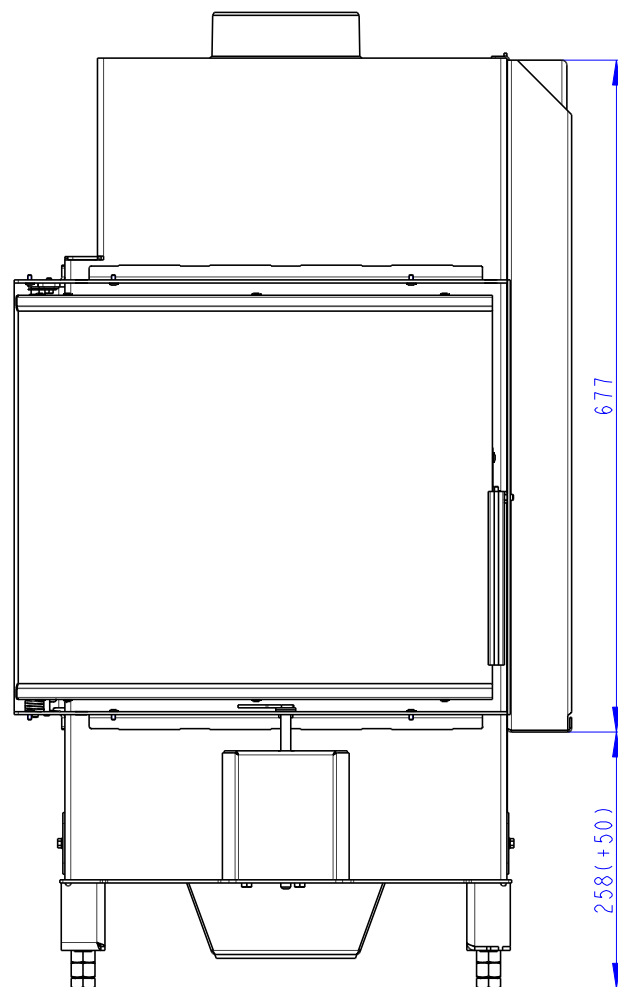
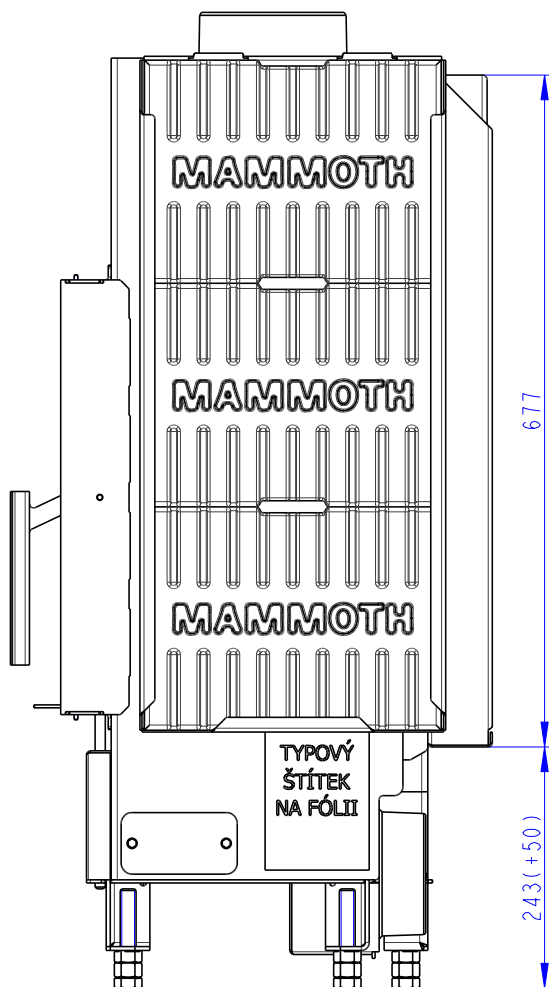

Rozmery v mm  
Dimensions in mm  
Maße in mm

Heat L 2g S 50.44.33.13(23)  
+ AKKUM KV 03  
170kg

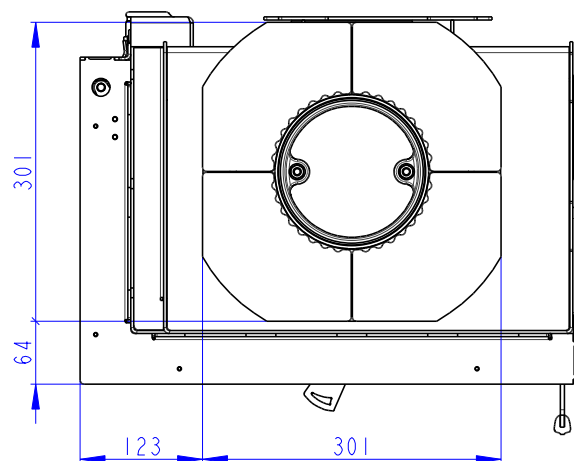
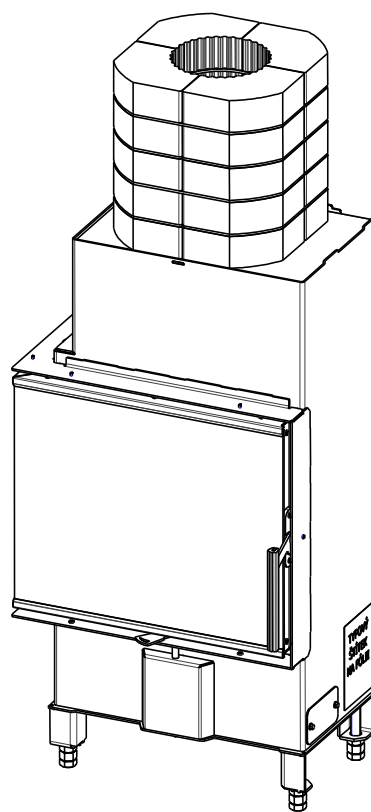
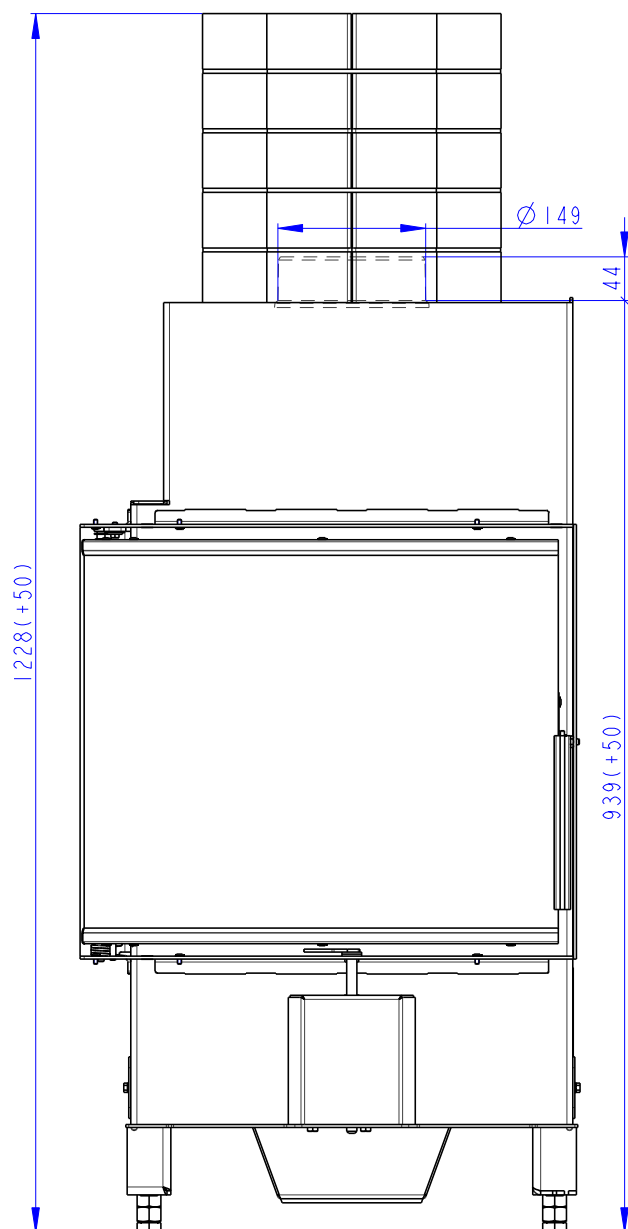

Rozměry v mm  
Dimensions in mm  
Maße in mm

Heat L 2g S 50.44.33.13(23)  
+ HR2SV RAM04  
100kg

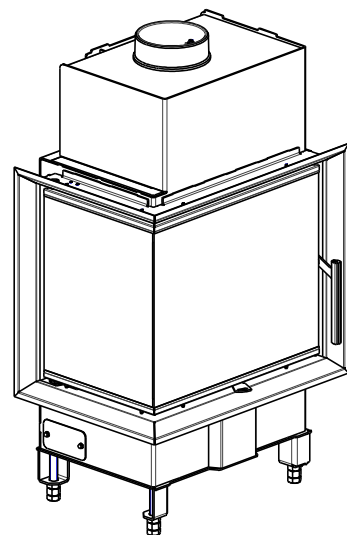
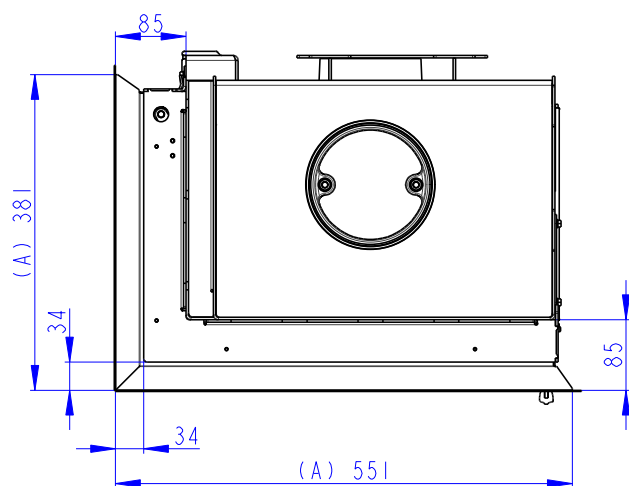
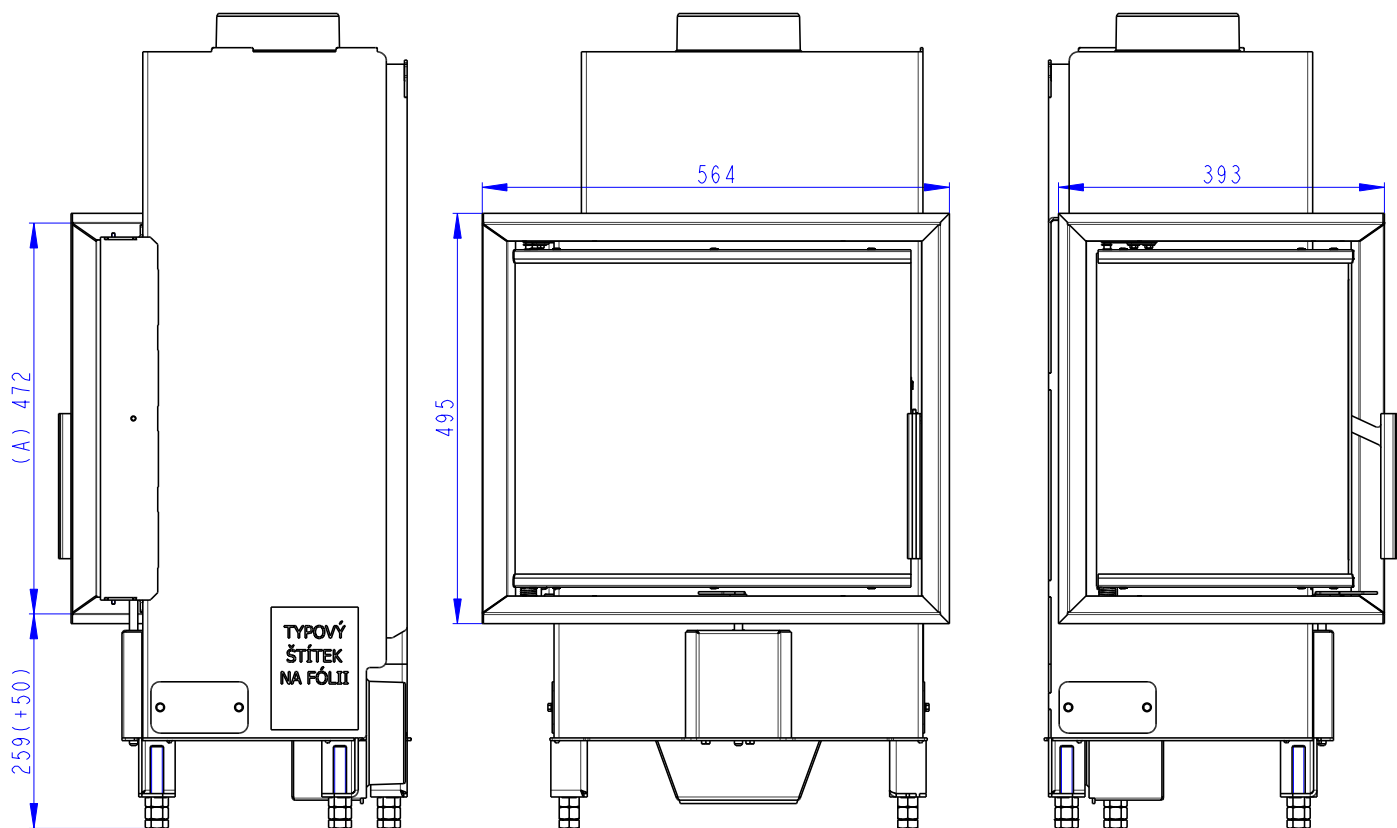

- (A) Zastavbovy rozmer / In-built dimension / Baumaße  
 (B) Litinový odvod kouře / Cast iron spigot / Der gusseiserne Rauchabgang  
 (C) Centrální privod vzduchu / Central air inlet / Zentralluftzufuhr  
 (D) Primární a sekundární vzduch / Primary and secondary air / Primärluft und Sekundärluft  
 (L) Volná plocha prosklení / Free glass area / Freie Glassichtfläche

Rozměry v mm  
Dimensions in mm  
Maße in mm

Heat L 2g S 50.44.33.13(23)  
+ HR2SV RAM06  
100kg

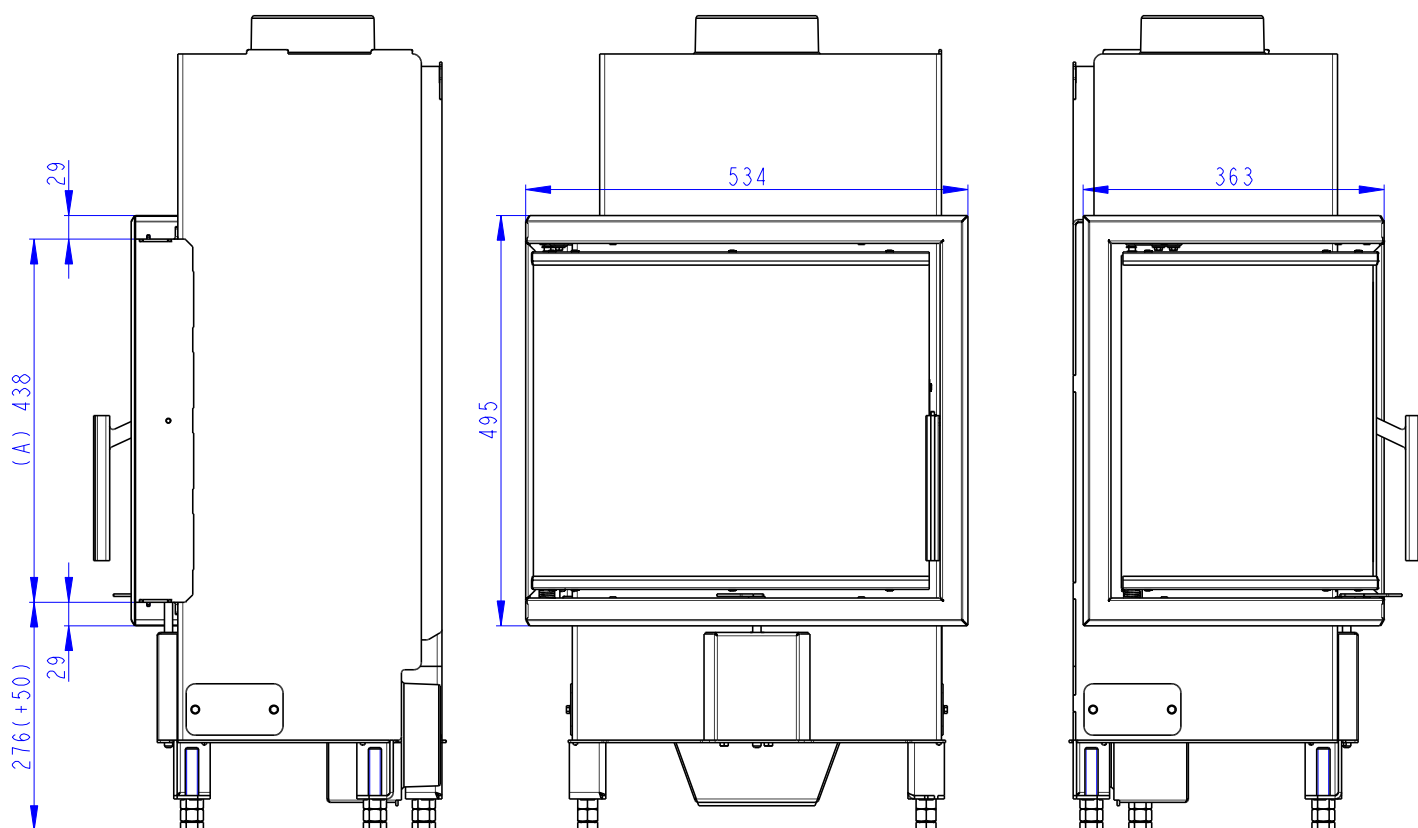

- (A) Zastavbovy rozmer / In-built dimension / Baumaße  
 (B) Litinový odvod kouře / Cast iron spigot / Der gusseiserne Rauchabgang  
 (C) Centrální přívod vzduchu / Central air inlet / Zentralluftzufuhr  
 (D) Primární a sekundární vzduch / Primary and secondary air / Primärluft und Sekundärluft  
 (L) Volná plocha prosklení / Free glass area / Freie Glassichtfläche

Rozměry v mm  
Dimensions in mm  
Maße in mm

Heat R 2g S 50.44.33.13(23)

100kg

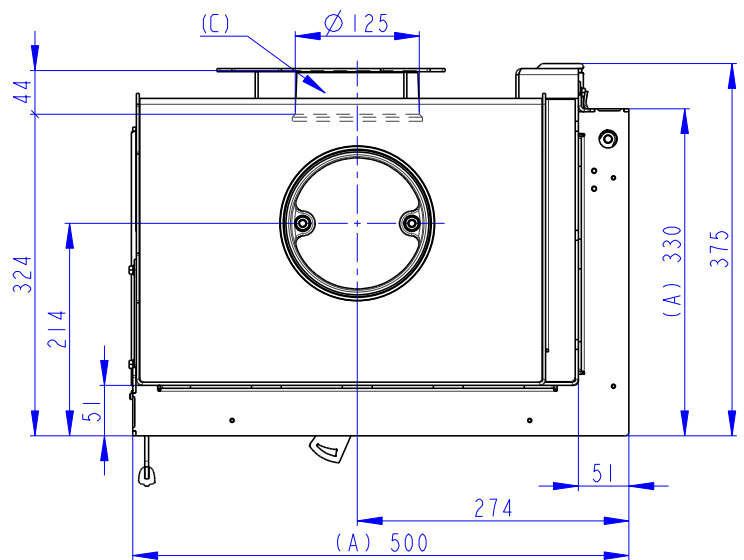
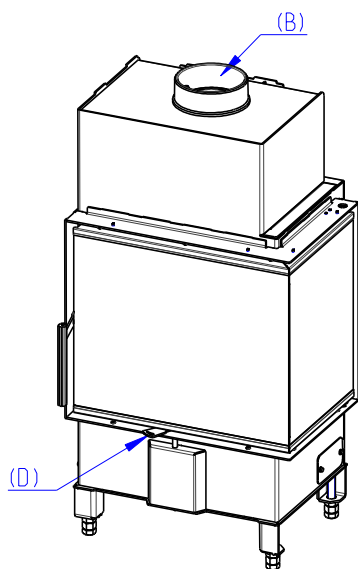
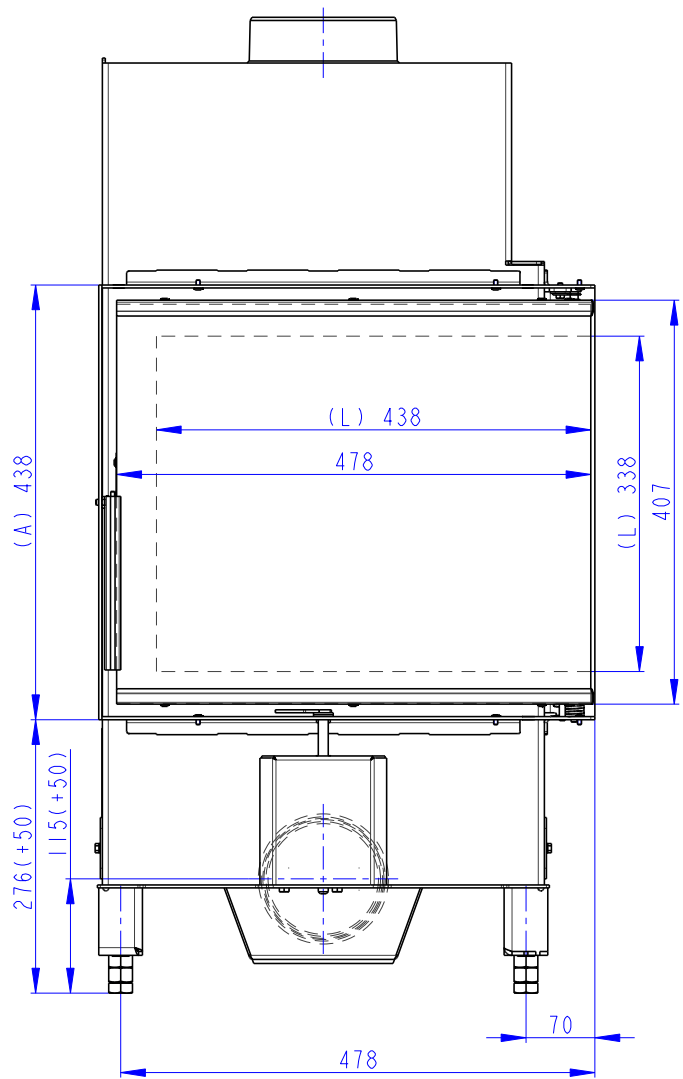
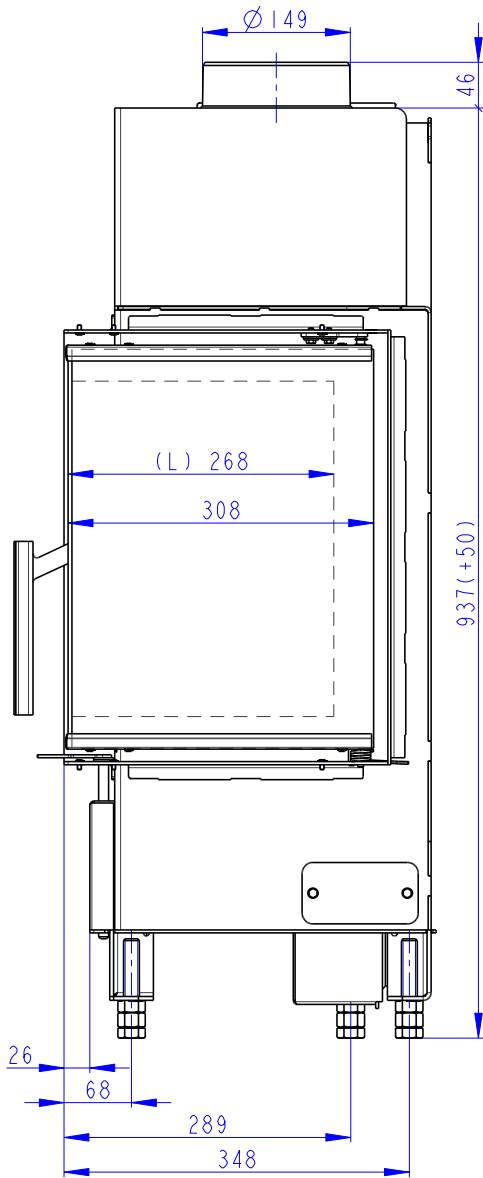

- (A) Zastavbovy rozmer / In-built dimension / Baumaße  
 (B) Litinový odvod kouře / Cast iron spigot / Der gusseiserne Rauchabgang  
 (C) Centrální privod vzduchu / Central air inlet / Zentralluftzufuhr  
 (D) Primární a sekundární vzduch / Primary and secondary air / Primärluft und Sekundärluft  
 (L) Volná plocha prosklení / Free glass area / Freie Glassichtfläche

Rozměry v mm  
Dimensions in mm  
Maße in mm

Heat R 2g S 50.44.33.13(23)  
+ H2 AIRBOX 01  
100kg

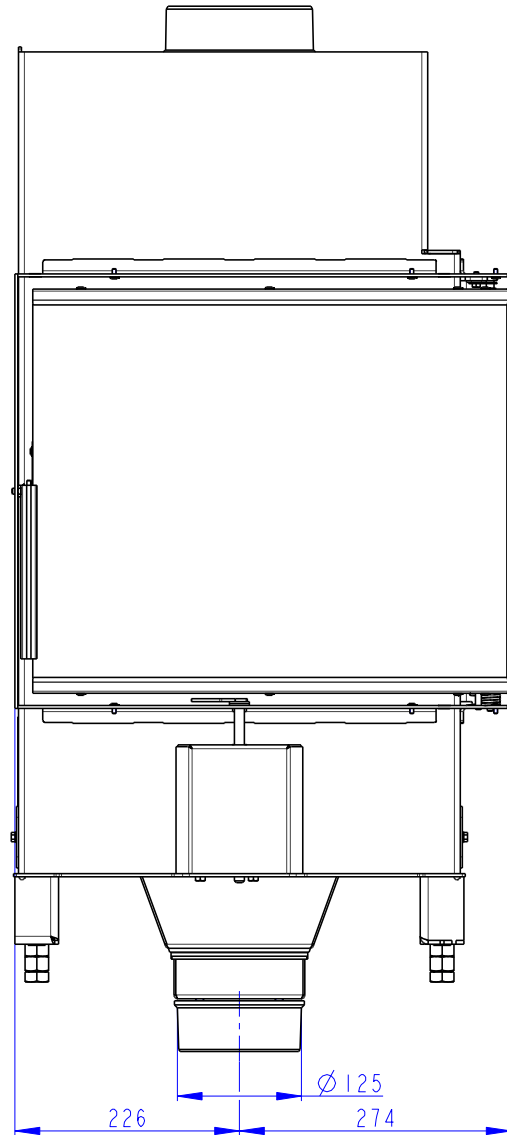
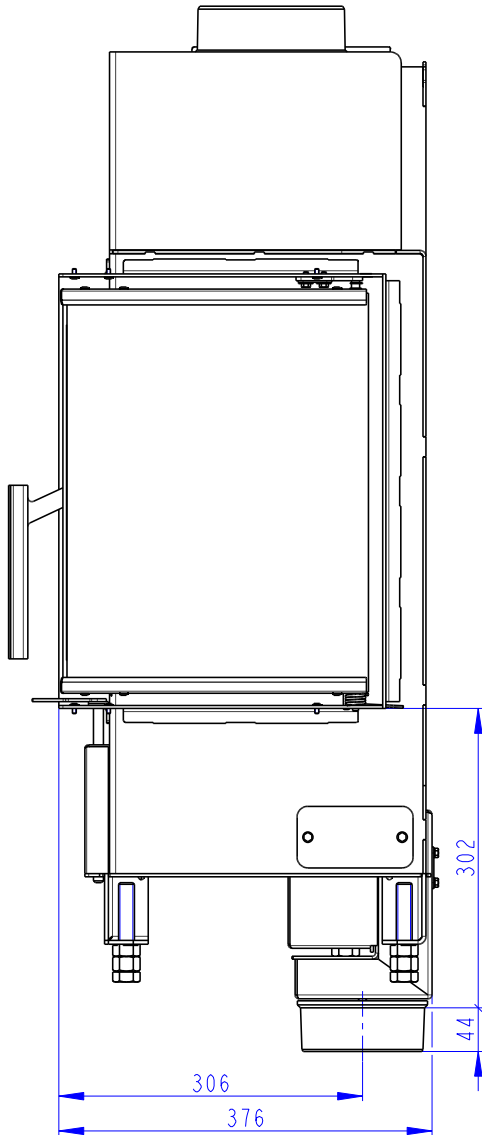

Rozměry v mm  
Dimensions in mm  
Maße in mm

Heat R 2g S 50.44.33.13(23)

+ AKKUM KV 02  
190kg

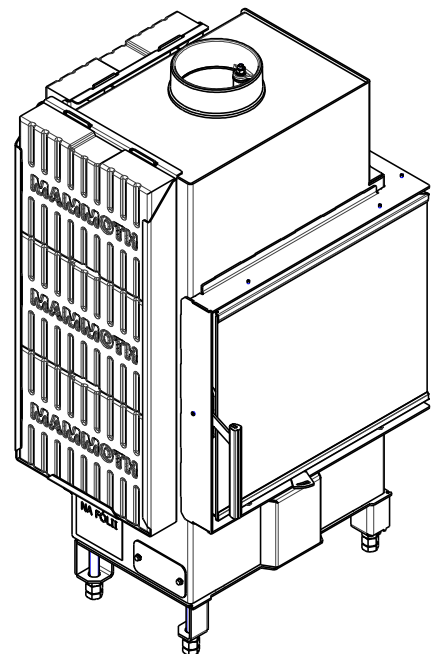
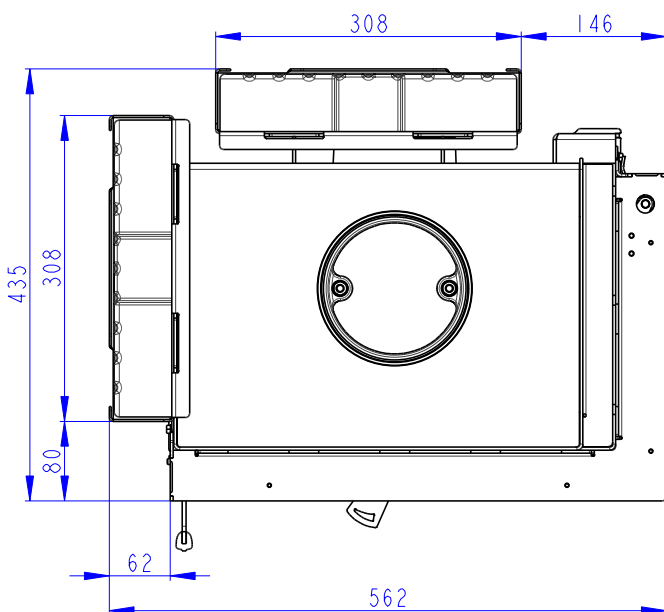
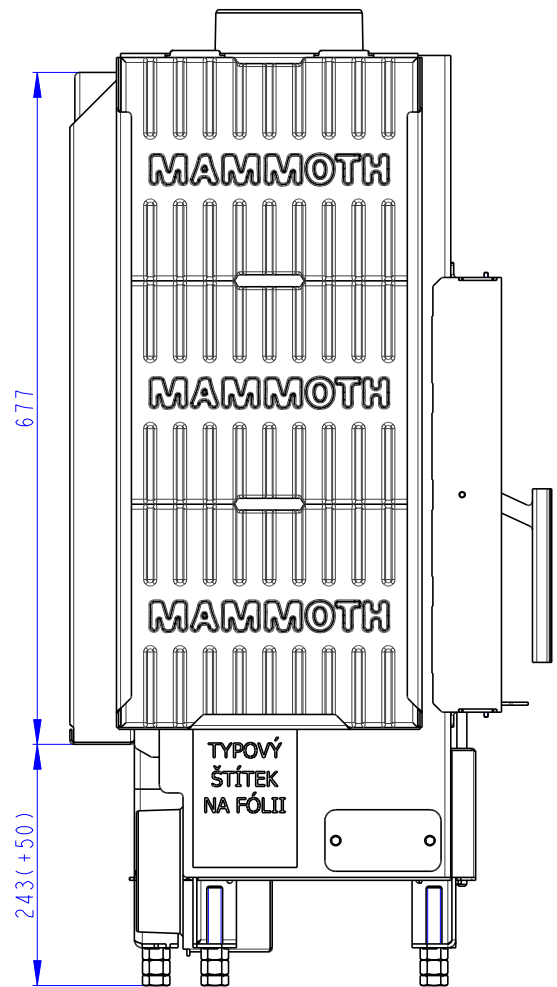
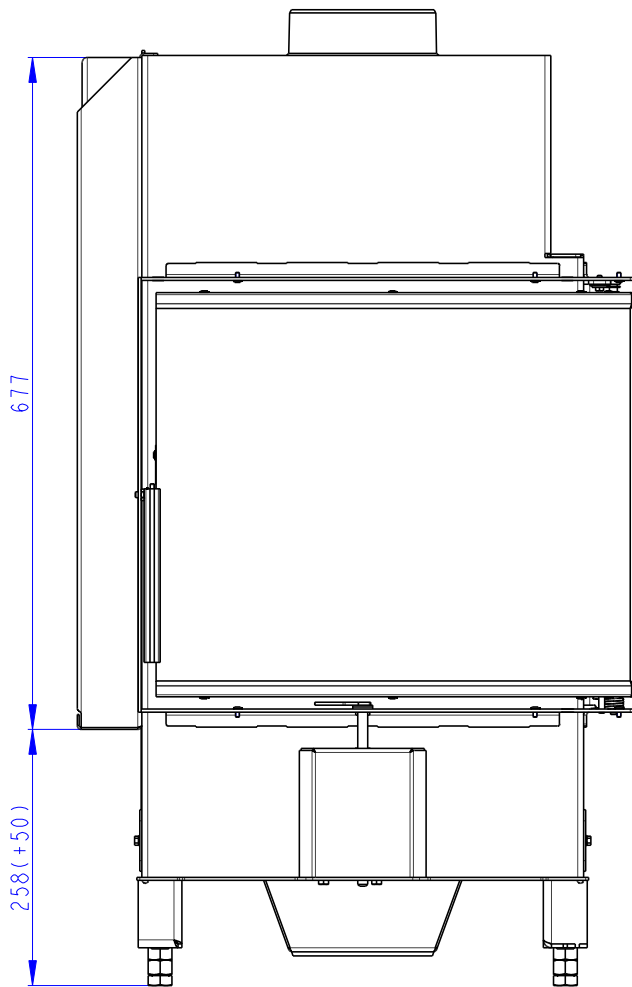

Rozměry v mm  
Dimensions in mm  
Maße in mm

Heat R 2g S 50.44.33.13(23)  
+ AKKUM KV 03  
170kg

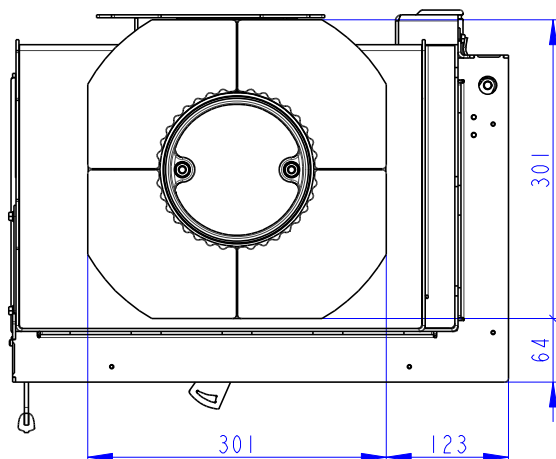
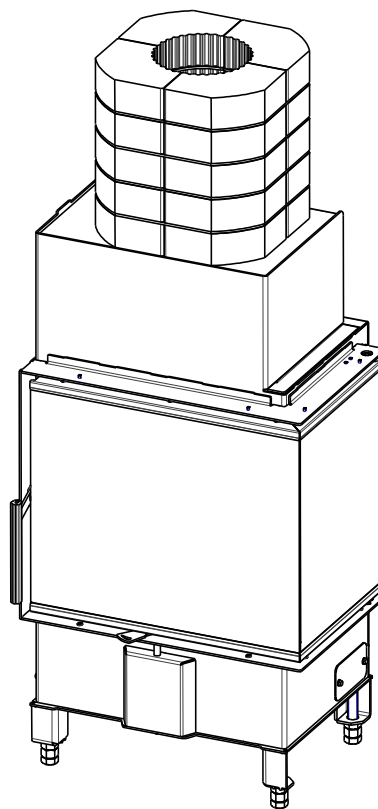
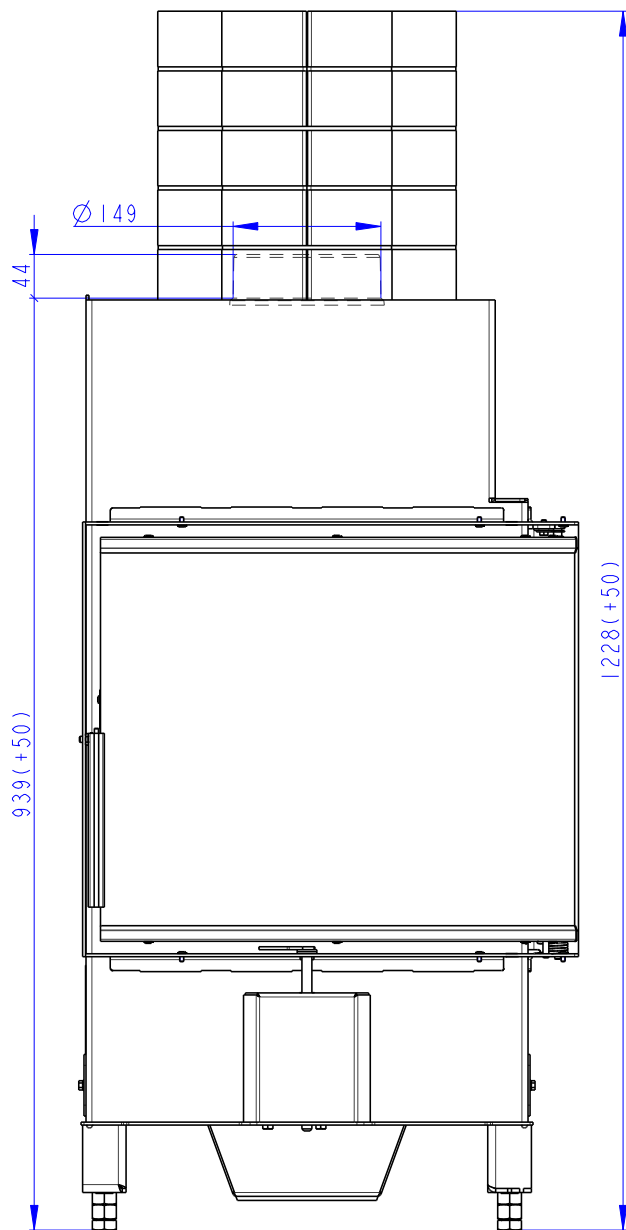



Rozměry v mm  
Dimensions in mm  
Maße in mm

Heat R 2g S 50.44.33.13(23)  
+ HR2SV RAM04  
100kg

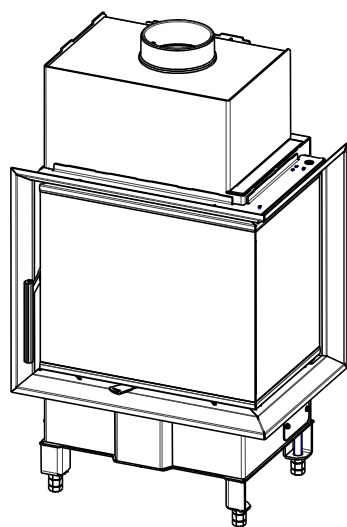
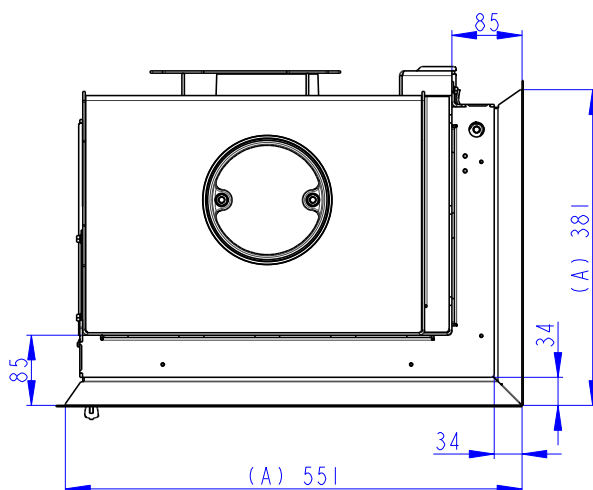
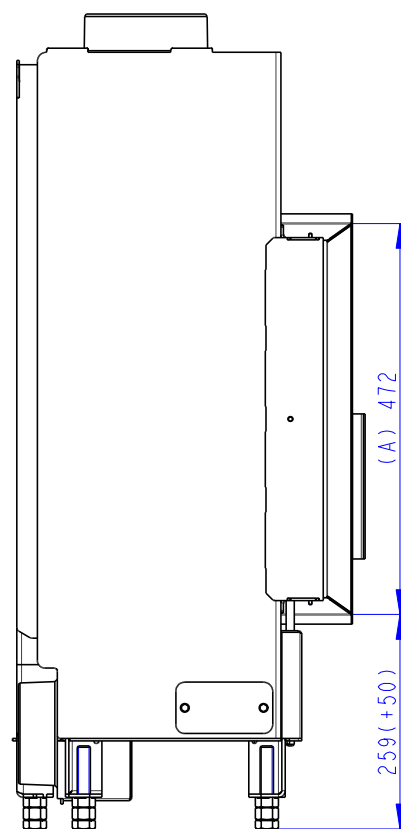
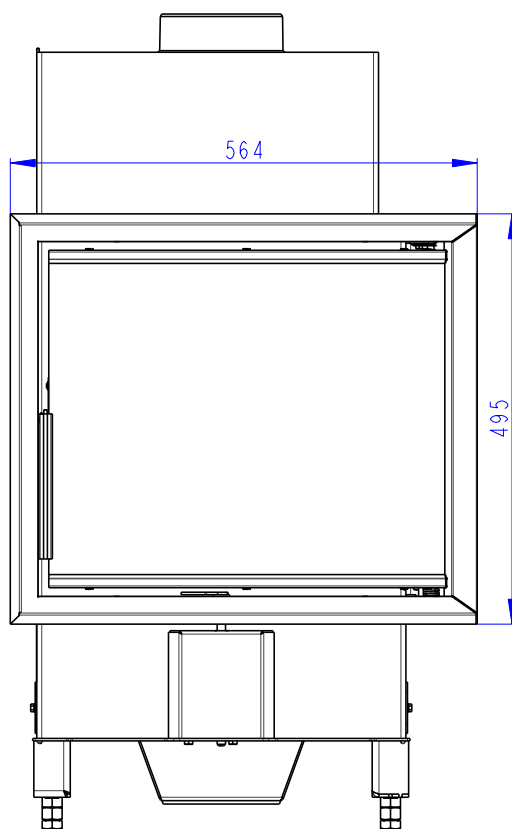
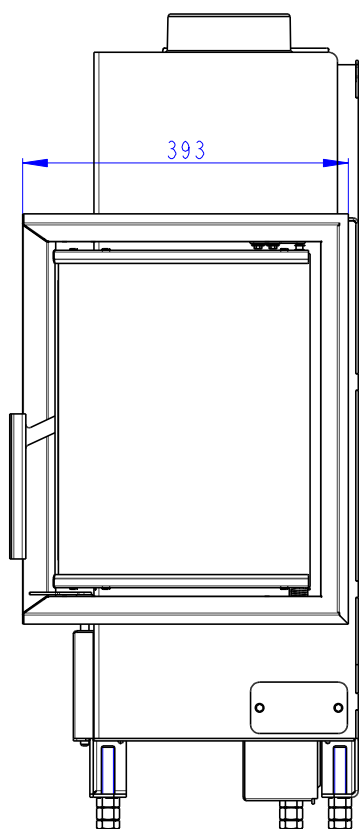

- (A) Zastavbovy rozmer / In-built dimension / Baumaße
- (B) Litinový odvod kouře / Cast iron spigot / Der gusseiserne Rauchabgang
- (C) Centrální přívod vzduchu / Central air inlet / Zentralluftzufuhr
- (D) Primární a sekundární vzduch / Primary and secondary air / Primärluft und Sekundärluft
- (L) Volná plocha prosklení / Free glass area / Freie Glassichtfläche

Rozměry v mm  
Dimensions in mm  
Maße in mm

Heat R 2g S 50.44.33.13(23)  
+ HR2SV RAM06  
100kg

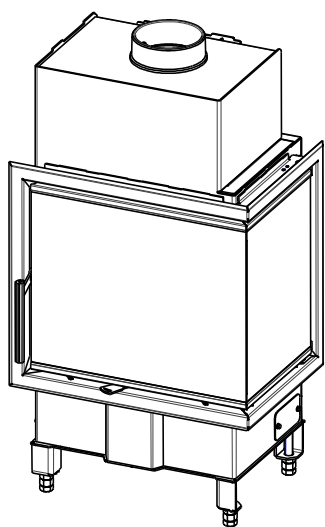
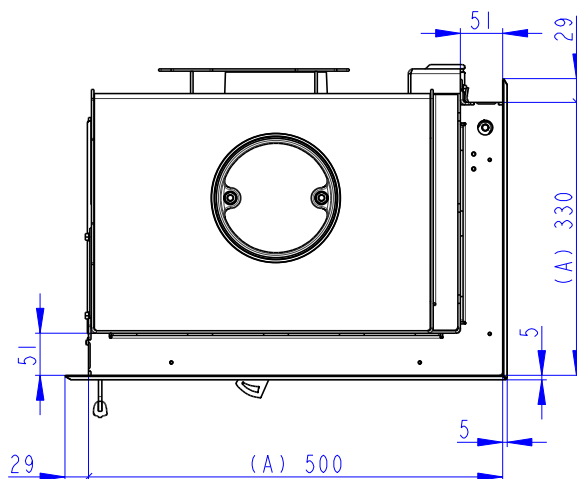
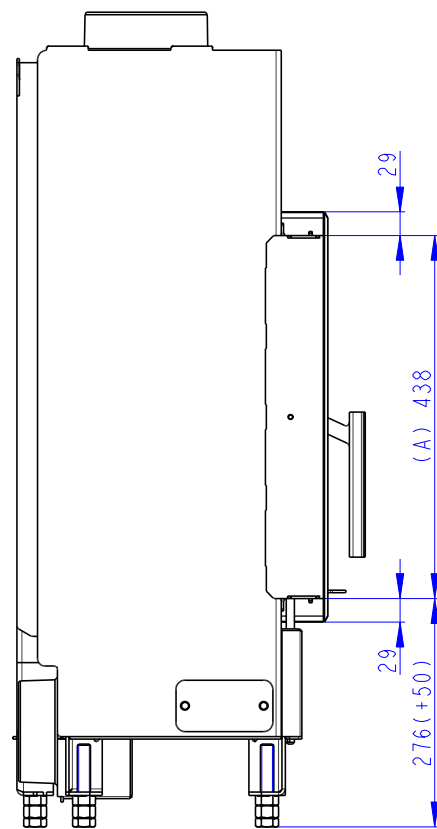
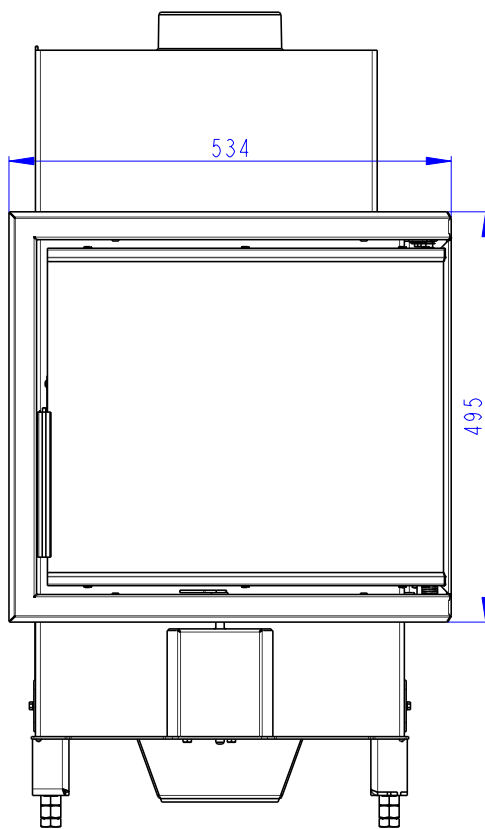
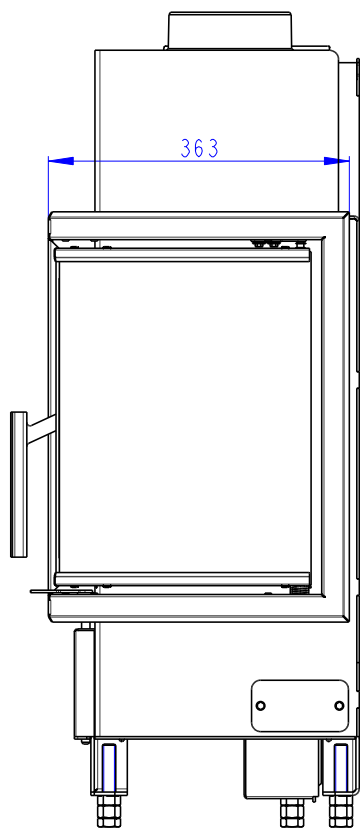

- (A) Zastavbovy rozmer / In-built dimension / Baumaße
- (B) Litinový odvod kouře / Cast iron spigot / Der gusseiserne Rauchabgang
- (C) Centrální přívod vzduchu / Central air inlet / Zentralluftzufuhr
- (D) Primární a sekundární vzduch / Primary and secondary air / Primärluft und Sekundärluft
- (L) Volná plocha prosklení / Free glass area / Freie Glassichtfläche

Rozměry v mm  
Dimensions in mm  
Maße in mm

Heat R 2g S 50.44.33.13(23)

100kg

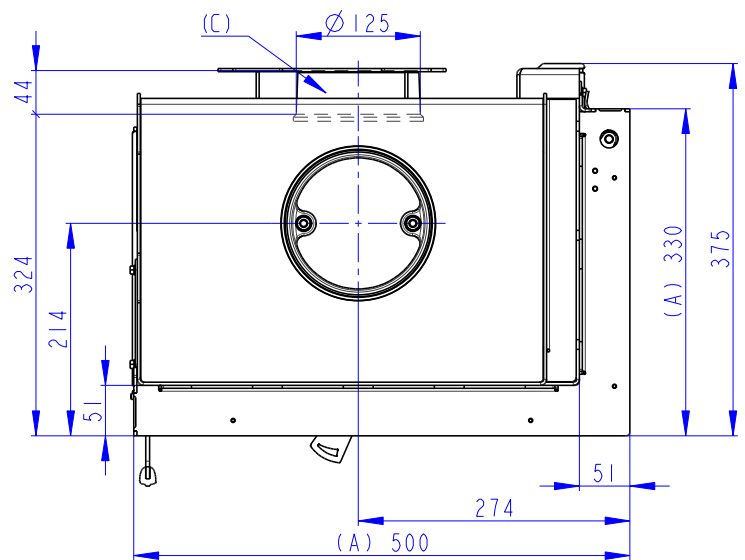
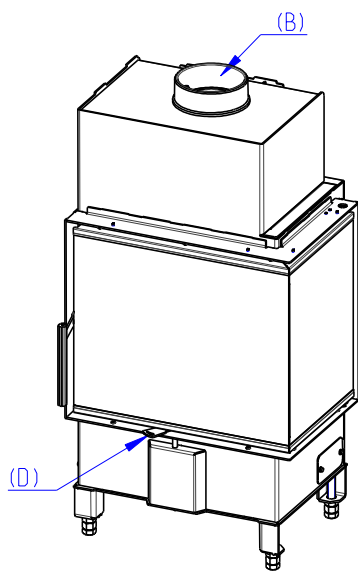
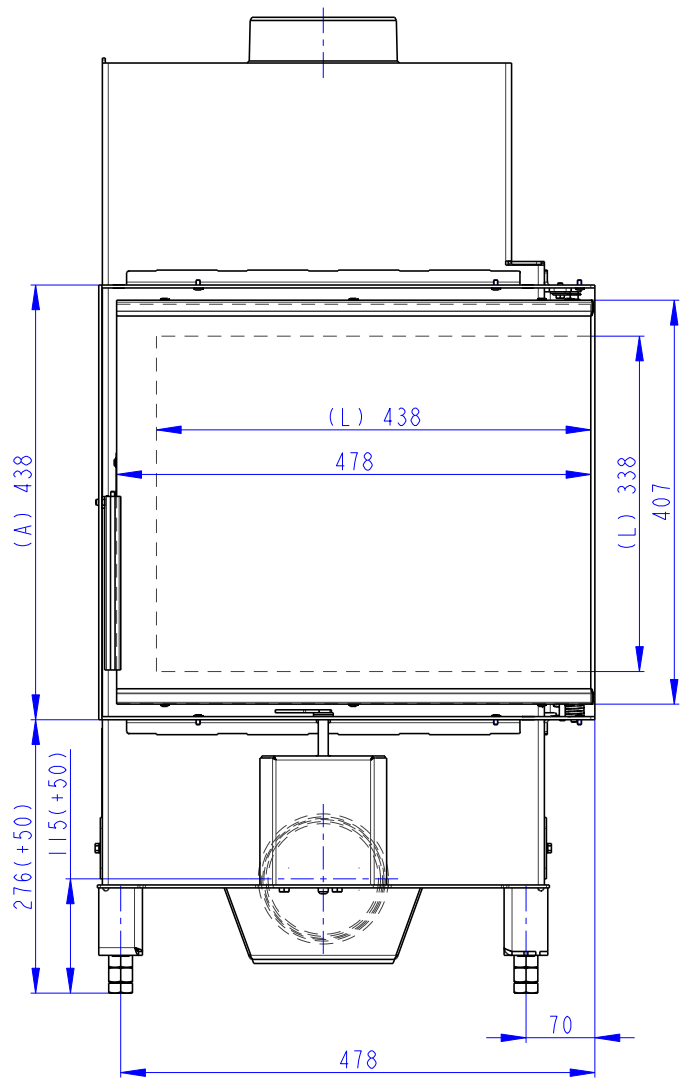
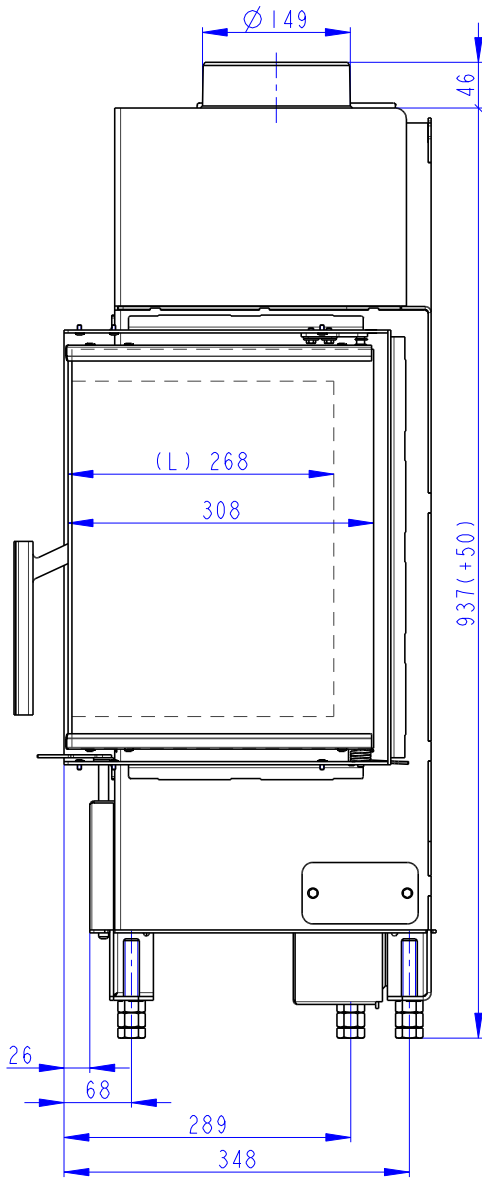

- (A) Zastavbovy rozmer / In-built dimension / Baumaße  
 (B) Litinový odvod kouře / Cast iron spigot / Der gusseiserne Rauchabgang  
 (C) Centrální privod vzduchu / Central air inlet / Zentralluftzufuhr  
 (D) Primární a sekundární vzduch / Primary and secondary air / Primärluft und Sekundärluft  
 (L) Volná plocha prosklení / Free glass area / Freie Glassichtfläche

Rozměry v mm  
Dimensions in mm  
Maße in mm

Heat R 2g S 50.44.33.13(23)  
+ H2 AIRBOX 01  
100kg

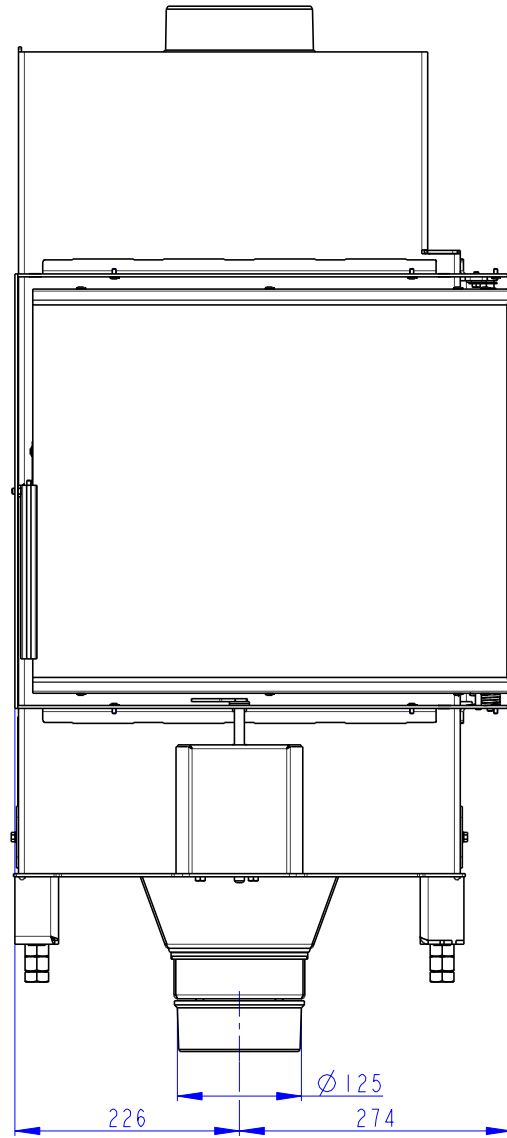
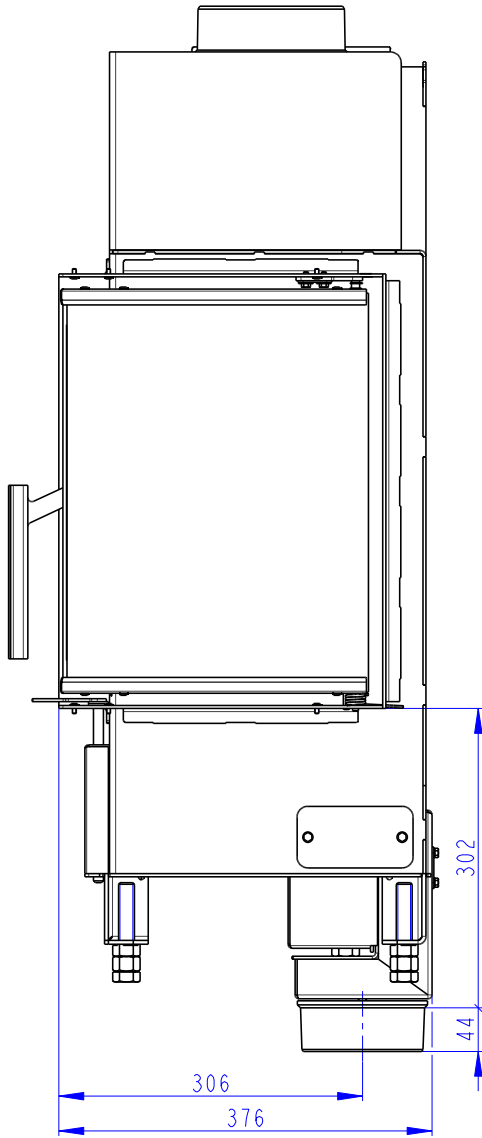

Rozměry v mm  
Dimensions in mm  
Maße in mm

Heat R 2g S 50.44.33.13(23)

+ AKKUM KV 02  
190kg

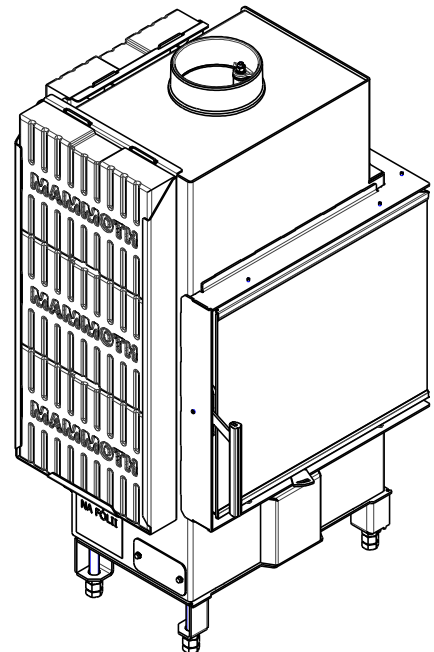
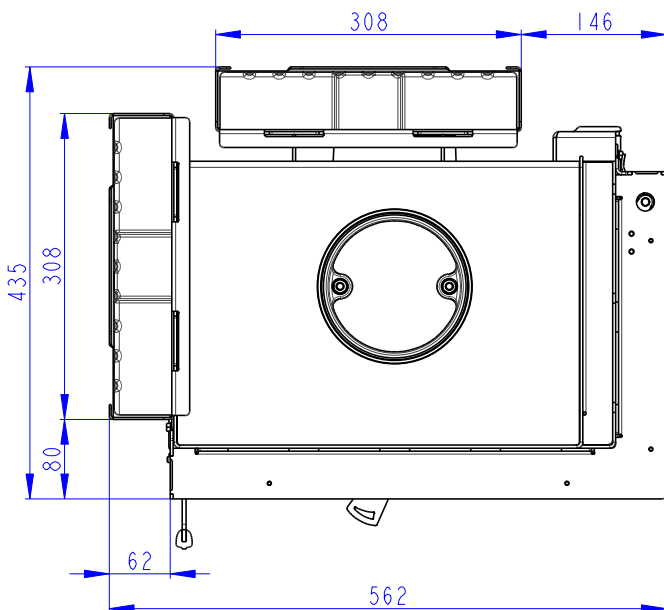
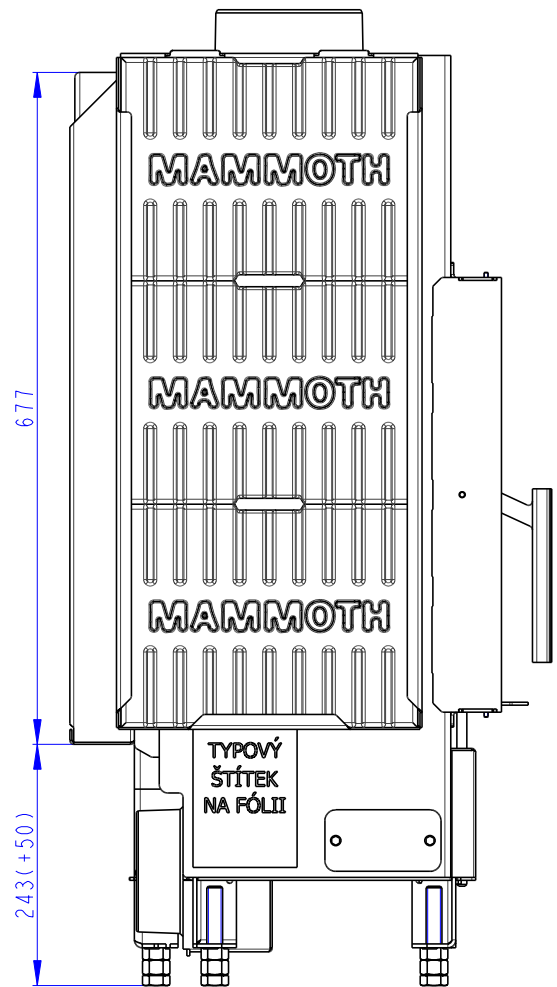
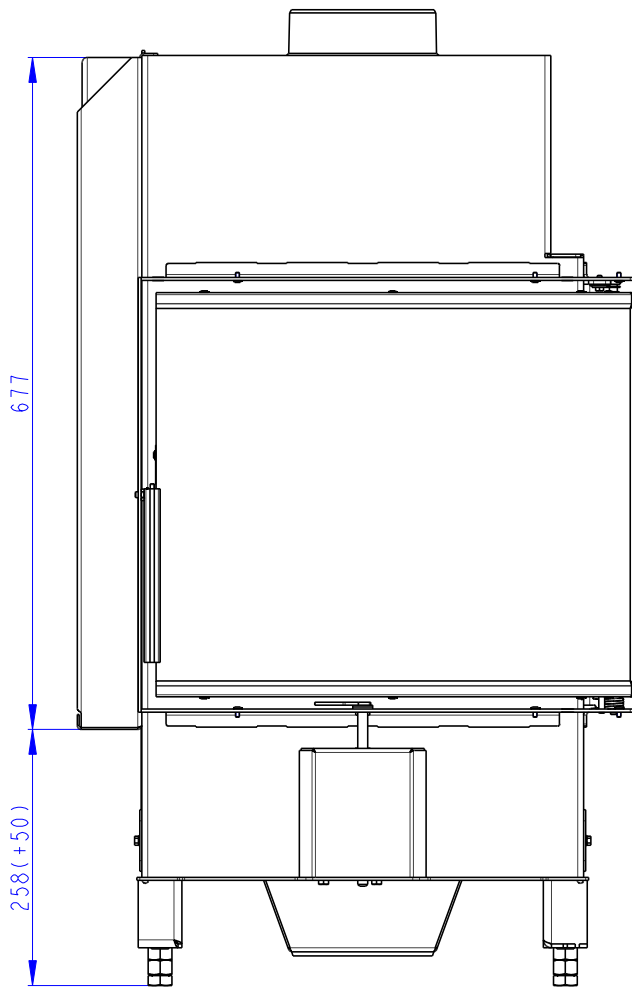

Rozměry v mm  
Dimensions in mm  
Maße in mm

Heat R 2g S 50.44.33.13(23)  
+ AKKUM KV 03  
170kg

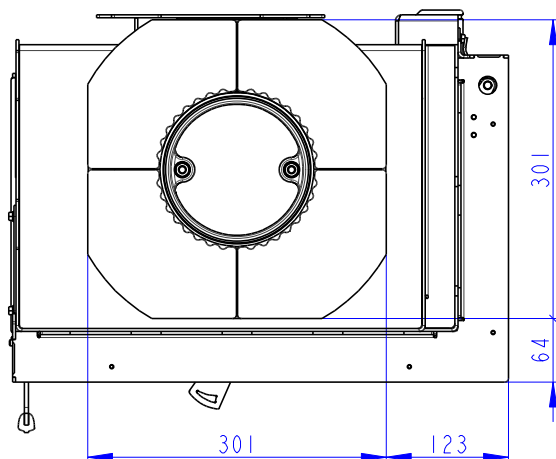
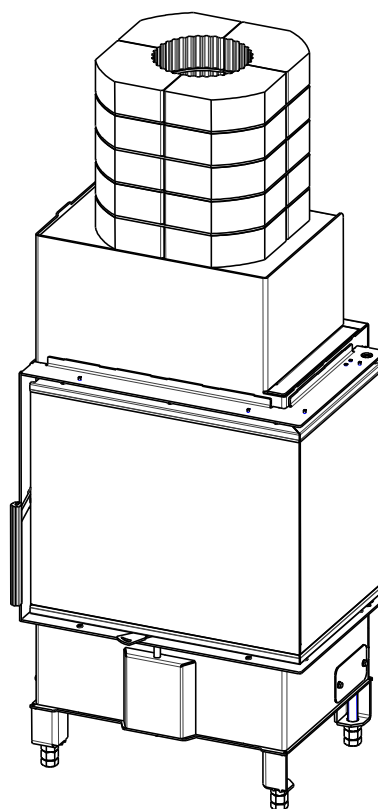
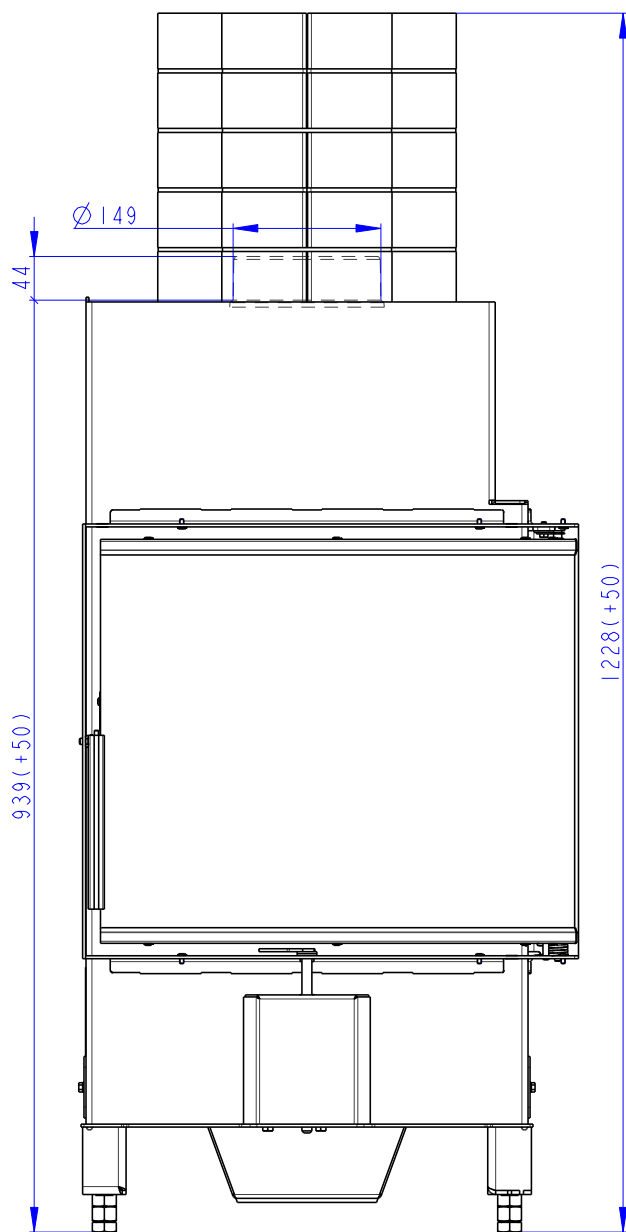

Rozměry v mm  
Dimensions in mm  
Maße in mm

Heat R 2g S 50.44.33.13(23)  
+ HR2SV RAM04  
100kg

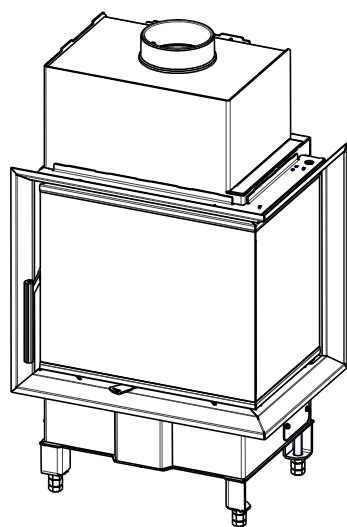
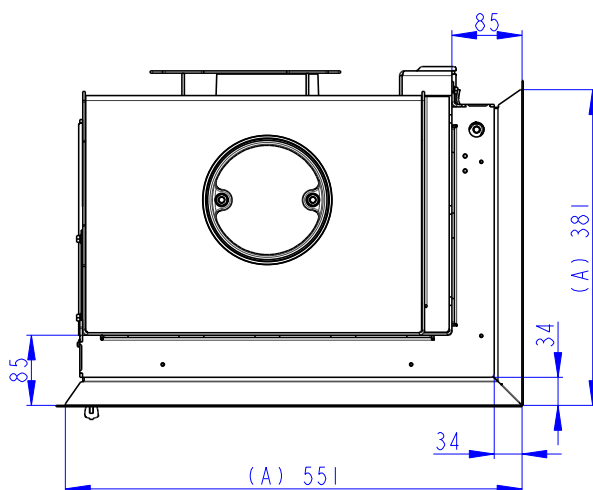
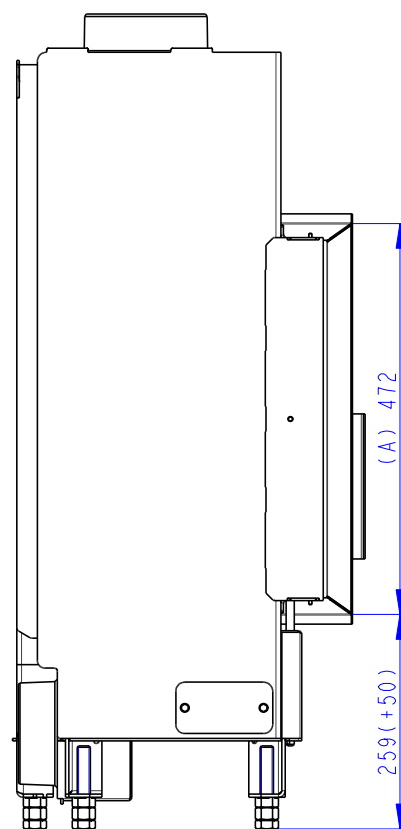
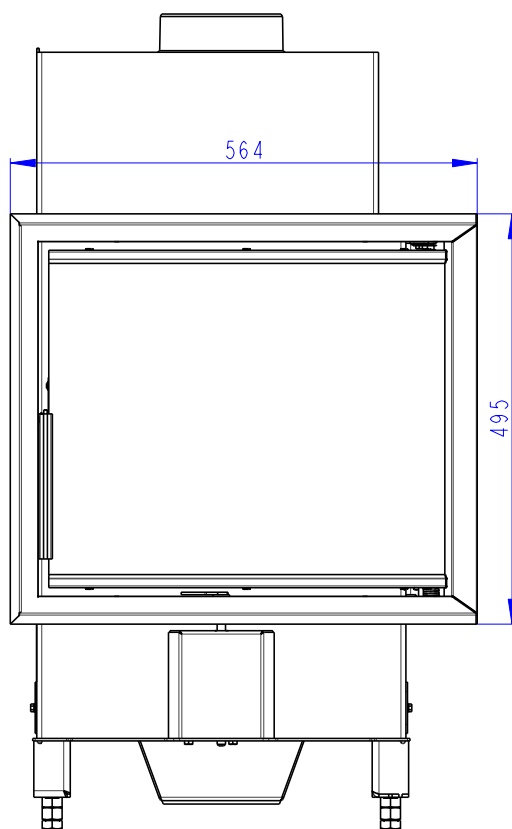
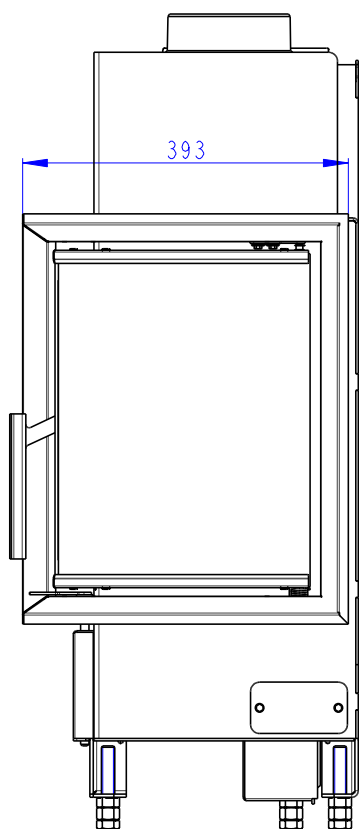

- (A) Zastavbovy rozmer / In-built dimension / Baumaße
- (B) Litinový odvod kouře / Cast iron spigot / Der gusseiserne Rauchabgang
- (C) Centrální přívod vzduchu / Central air inlet / Zentralluftzufuhr
- (D) Primární a sekundární vzduch / Primary and secondary air / Primärluft und Sekundärluft
- (L) Volná plocha prosklení / Free glass area / Freie Glassichtfläche

Rozměry v mm  
Dimensions in mm  
Maße in mm

Heat R 2g S 50.44.33.13(23)  
+ HR2SV RAM06  
100kg

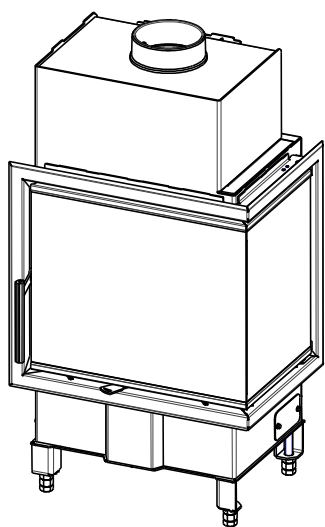
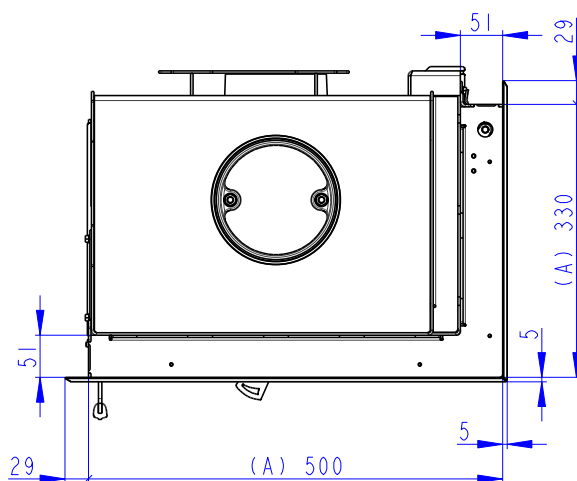
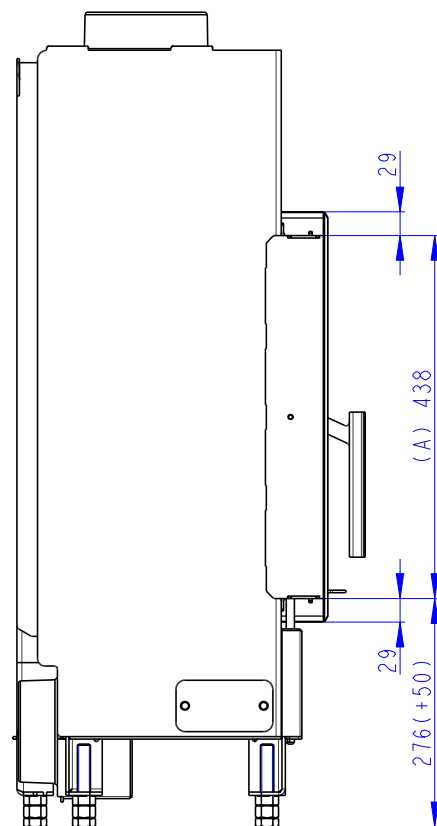
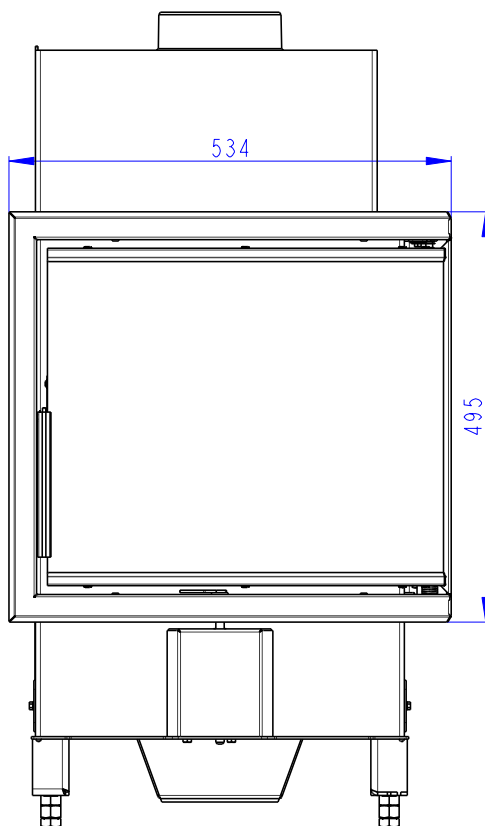
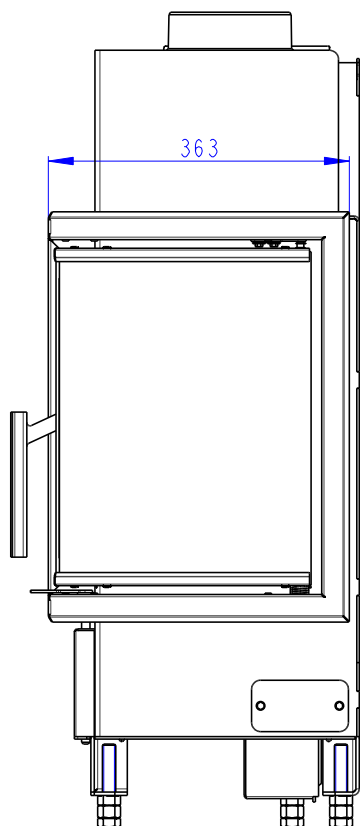

- (A) Zastavbovy rozmer / In-built dimension / Baumaße
- (B) Litinový odvod kouře / Cast iron spigot / Der gusseiserne Rauchabgang
- (C) Centrální přívod vzduchu / Central air inlet / Zentralluftzufuhr
- (D) Primární a sekundární vzduch / Primary and secondary air / Primärluft und Sekundärluft
- (L) Volná plocha prosklení / Free glass area / Freie Glassichtfläche