

- (A) Zastavbovy rozmer / In-built dimension / Baumaße / Dimension intégrée
 (B) Litinový odvod kouře / Cast iron spigot / Der gusseiserne Rauchabgang / Sortie de fumée en fonte
 (C) Centralní privod vzduchu / Central air inlet / Zentralluftzufuhr / Arrivée d'air extérieur
 (D) Primární a sekundární vzduch / Primary and secondary air / Primärluft und Sekundärluft / Air primaire et secondaire
 (L) Volná plocha prosklení / Free glass area / Freie Glassichtfläche / Surface en verre libre

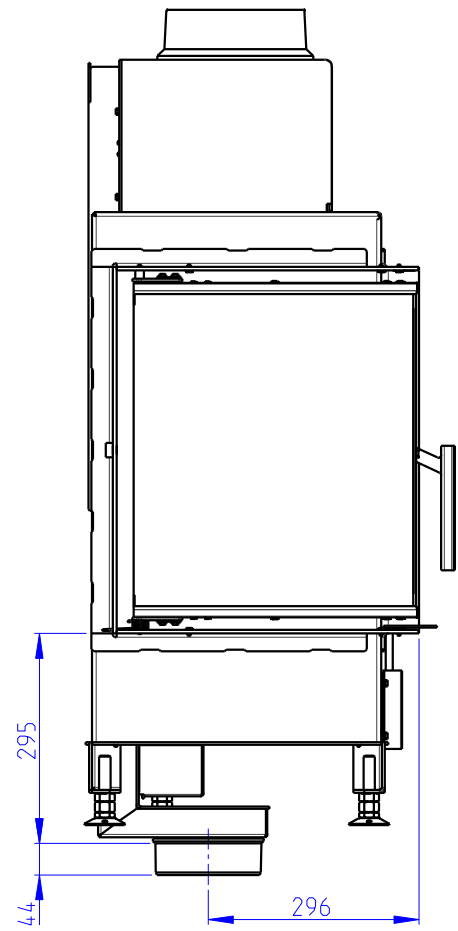

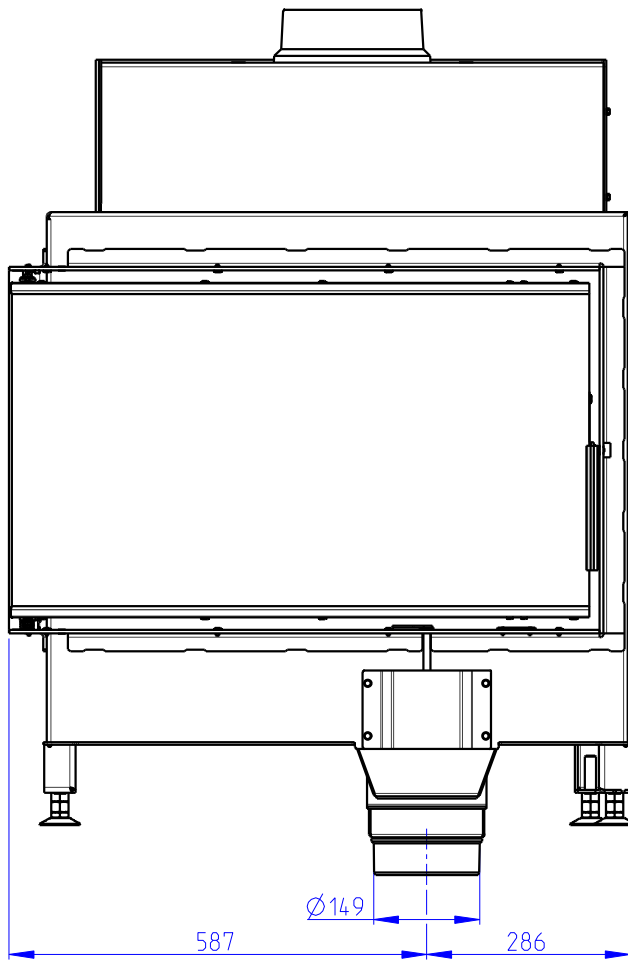

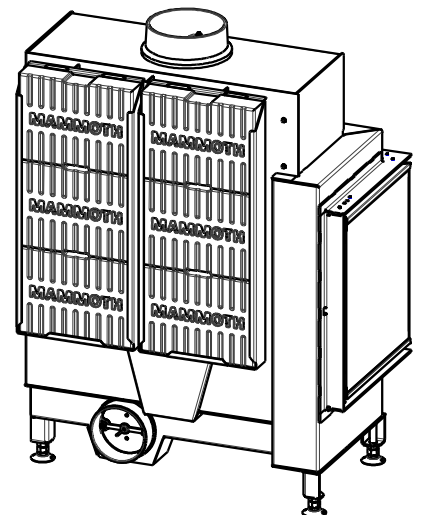

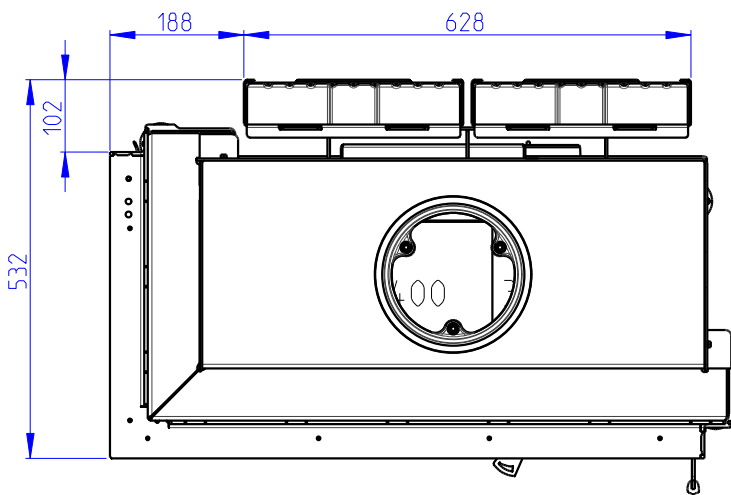
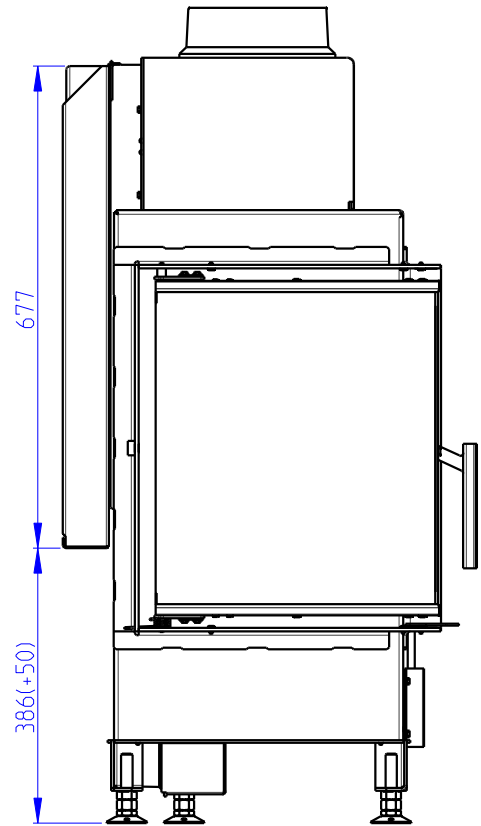
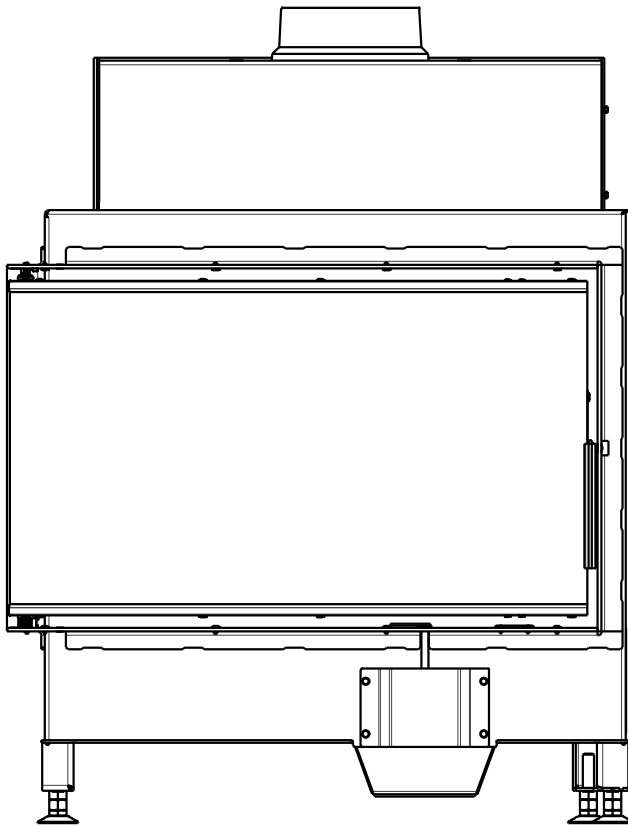
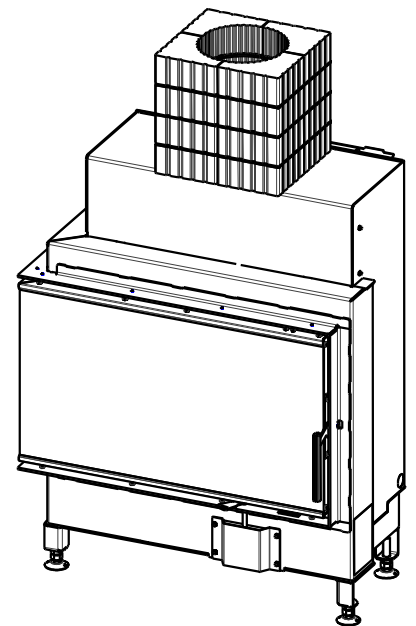
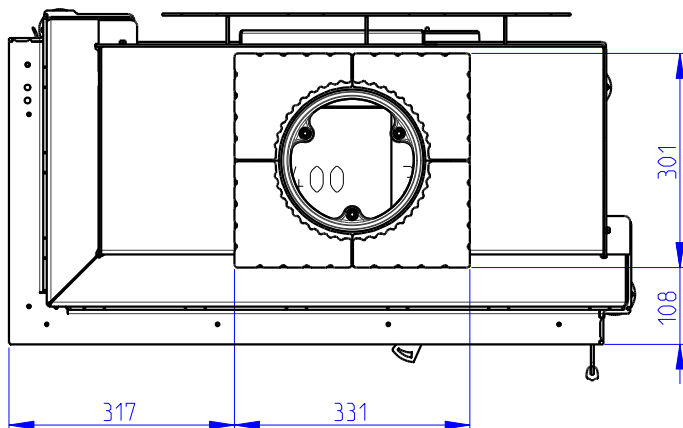
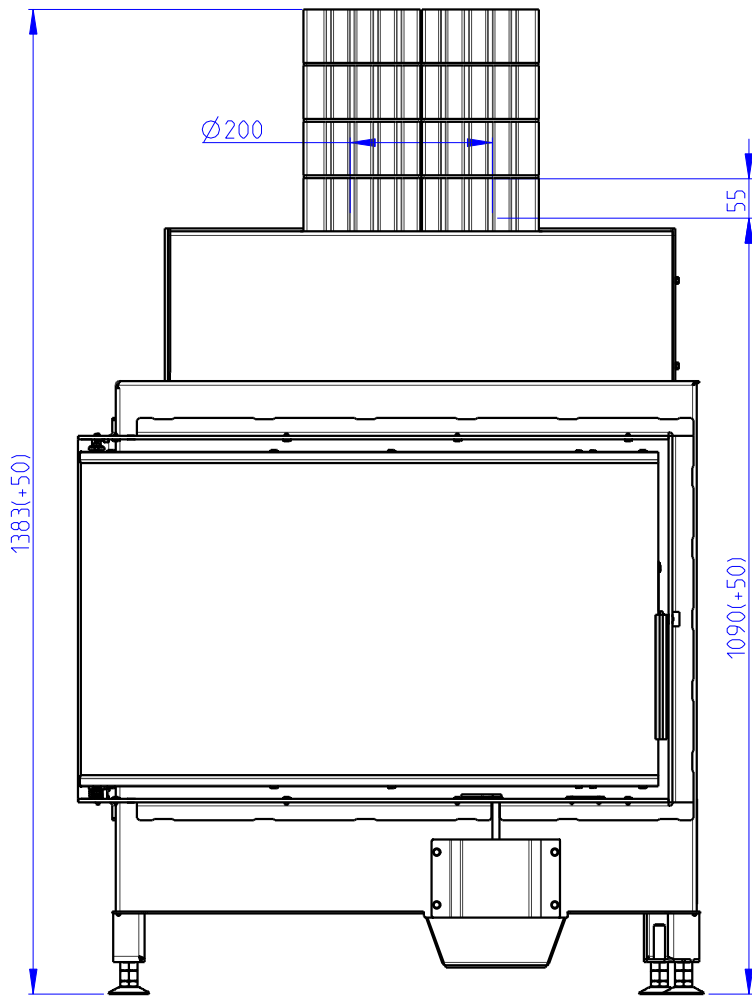
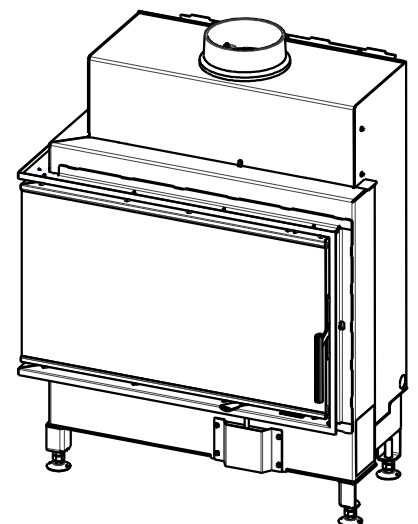
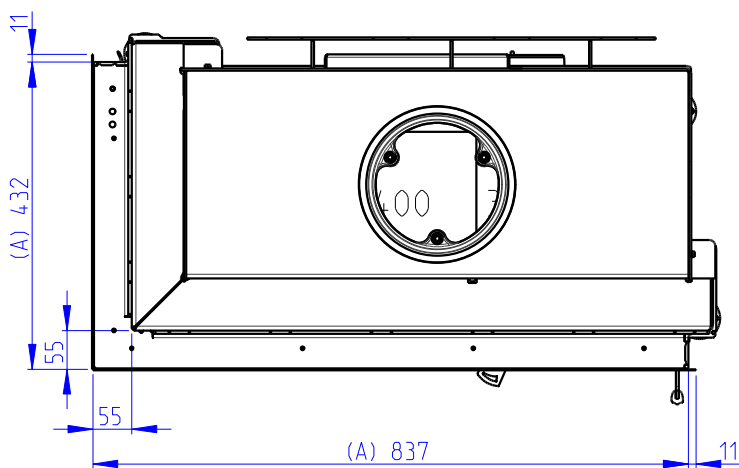
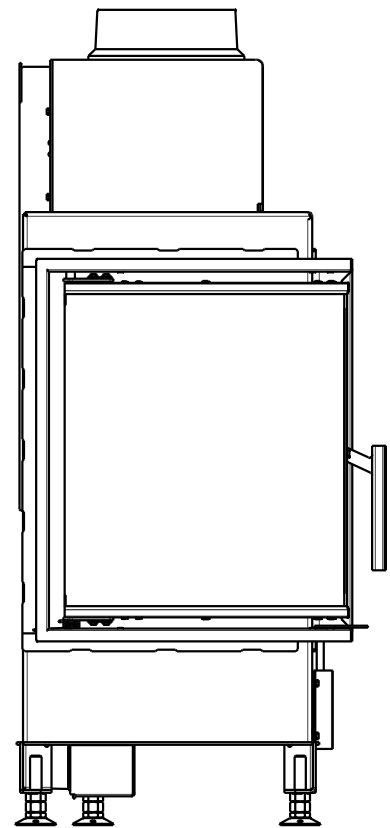
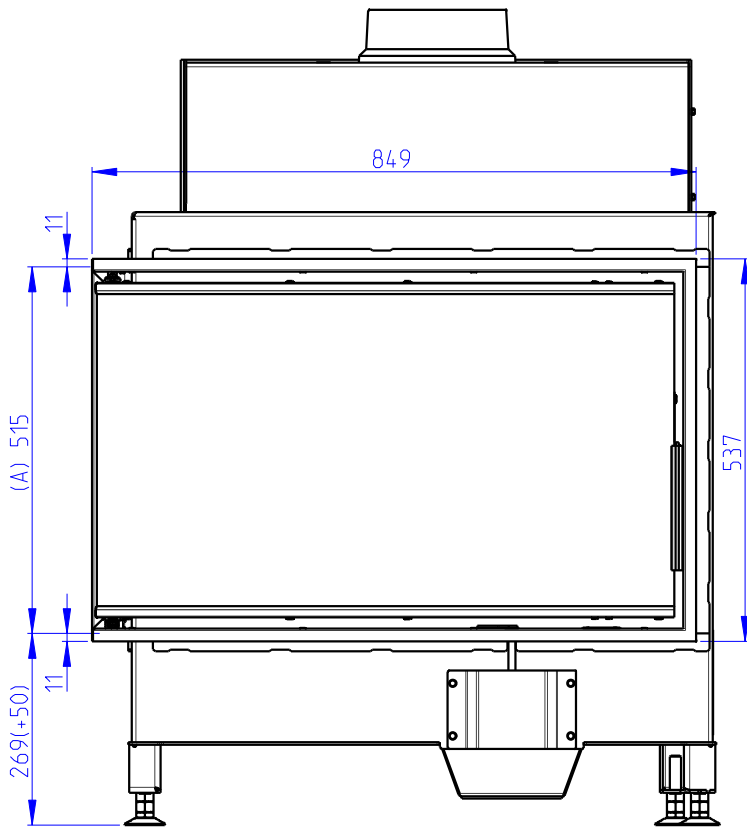

Rozměry v mm
 Maße in mm
 Dimensions in mm

Heat L 2g S 81.51.40.01(21)

190kg

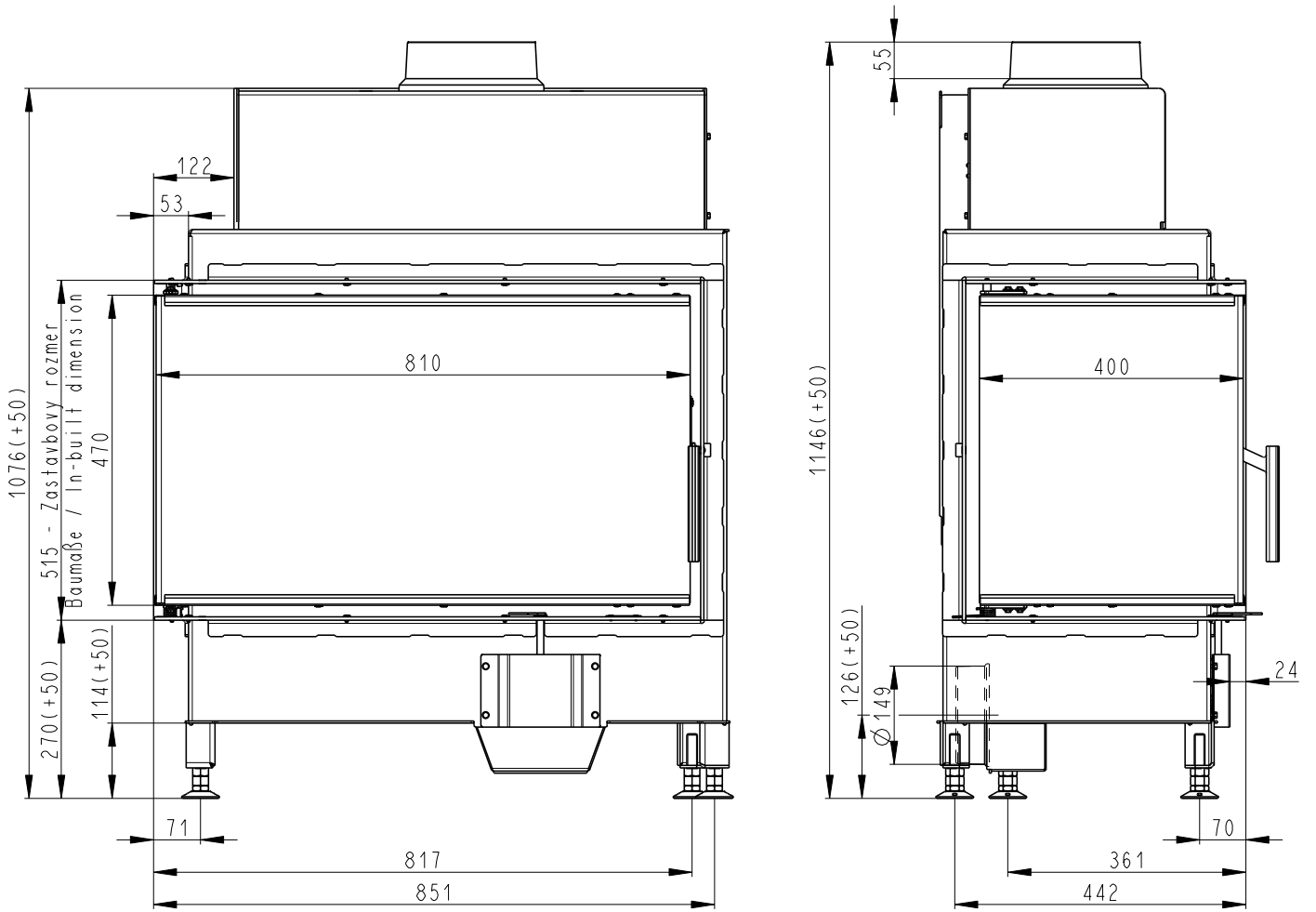

Litínový odvod kouře
 Cast iron spigot
 Der gusseiserne Rauchabgang

Primární a sekundární vzduch
 Primary and secondary air
 Primärluft und Sekundärluft

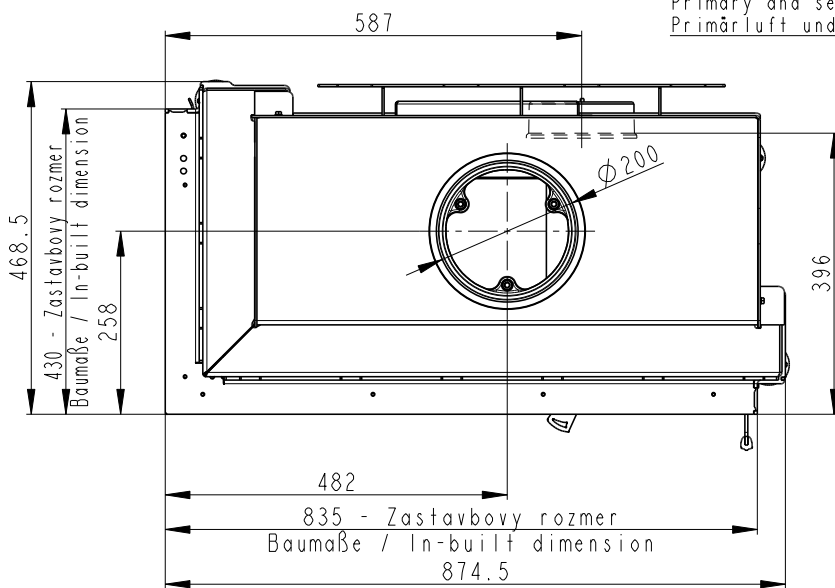

Centrální přívod vzduchu
 Central air inlet
 Zentralluftzufuhr

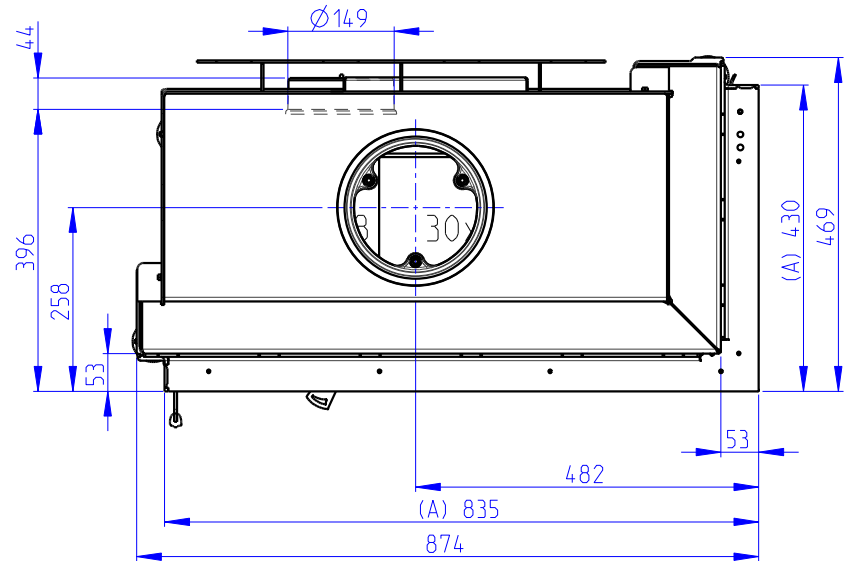
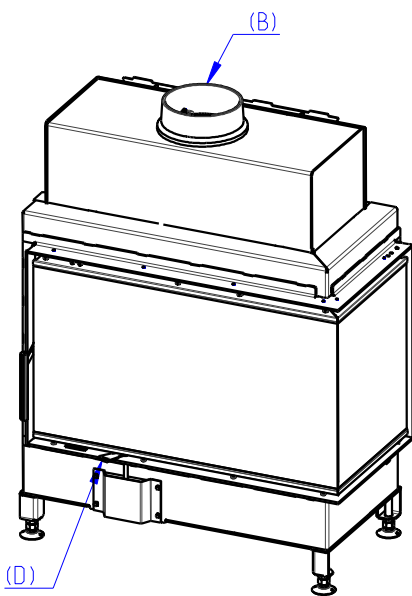
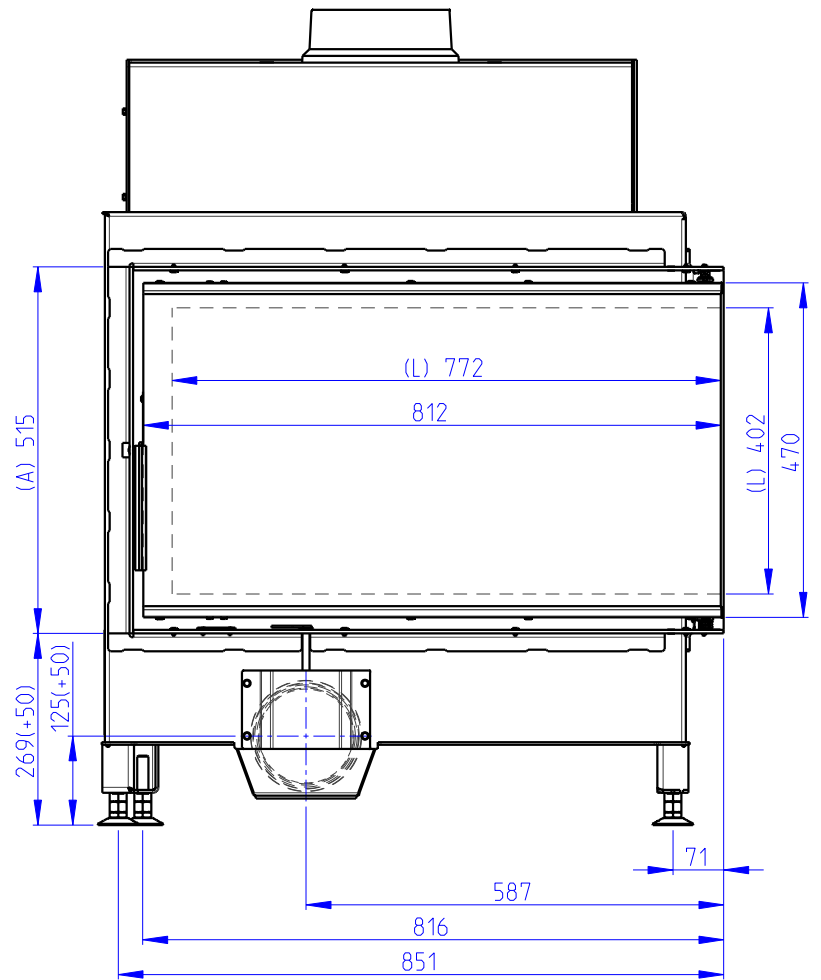
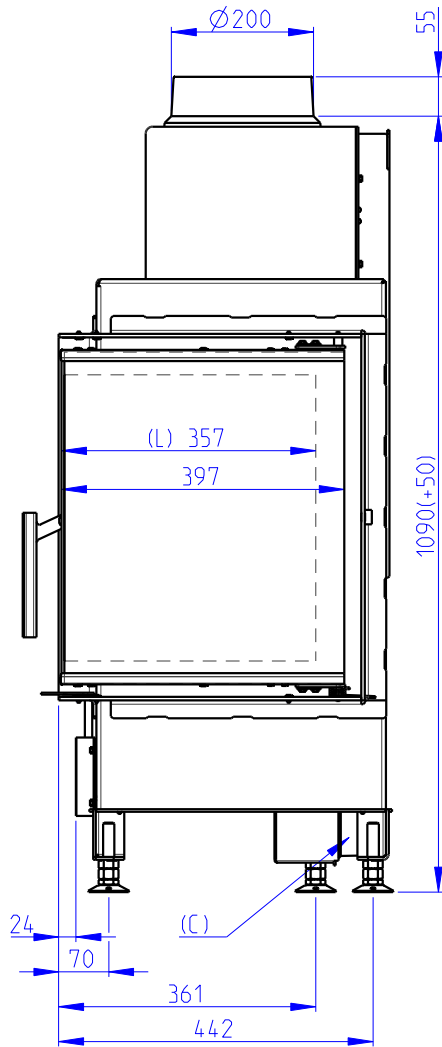

- (A) Zastavbovy rozmer / In-built dimension / Baumaße / Dimension intégrée
- (B) Litinový odvod kouře / Cast iron spigot / Der gusseiserne Rauchabgang / Sortie de fumée en fonte
- (C) Centralni privod vzduchu / Central air inlet / Zentralluftzufuhr / Arrivée d'air extérieur
- (D) Primarni a sekundarni vzduch / Primary and secondary air / Primärluft und Sekundärluft / Air primaire et secondaire
- (L) Volna plocha proskleni / Free glass area / Freie Glassichtfläche / Surface en verre libre

