

Rozměry v mm
Dimensions in mm
Maße in mm

Heat L 3g L 50.51.40.21
190kg

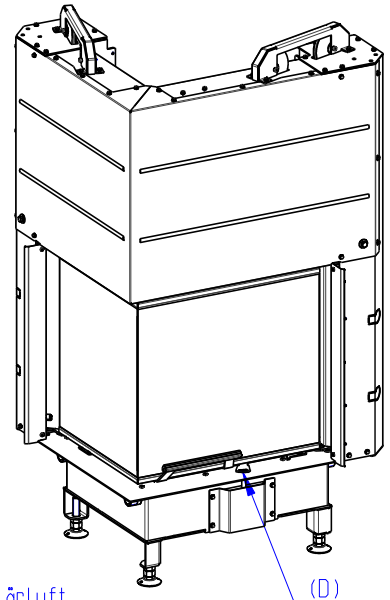
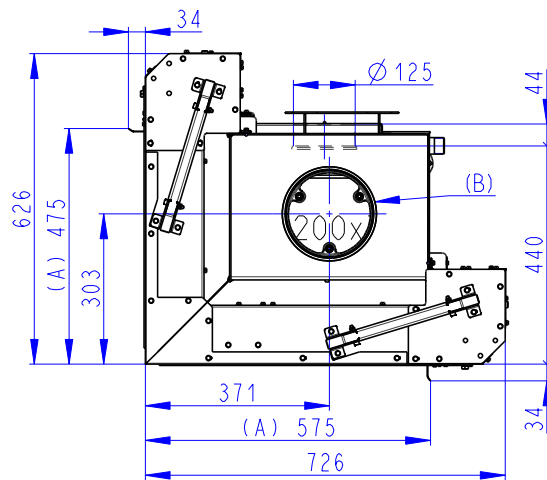
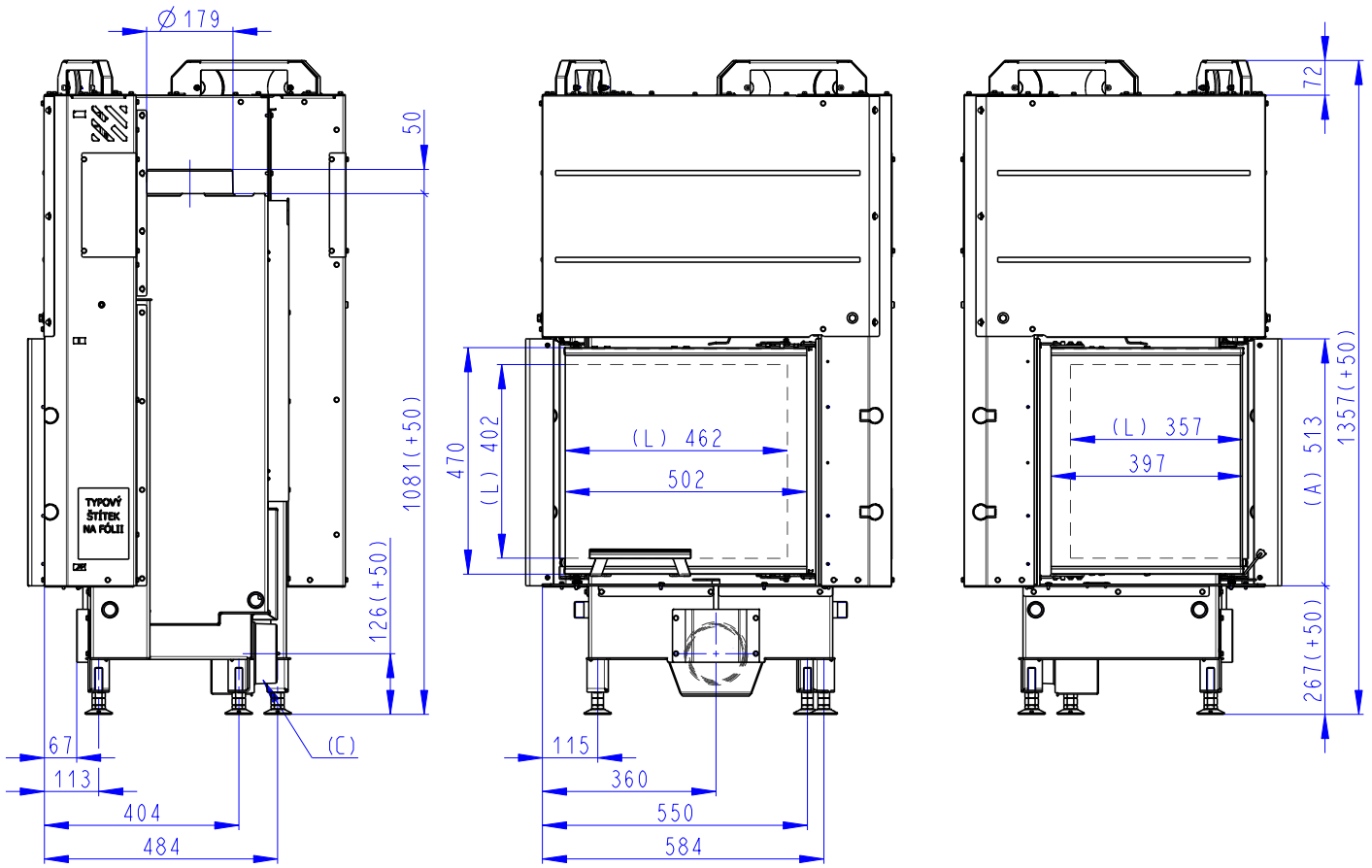

- (A) Zastavbovy rozmer / In-built dimension / Baumaße
- (B) Litinový odvod kouře / Cast iron spigot / Der gusseiserne Rauchabgang
- (C) Centrální privod vzduchu / Central air inlet / Zentralluftzufuhr
- (D) Primární a sekundární vzduch / Primary and secondary air / Primärluft und Sekundärluft
- (L) Volná plocha prosklení / Free glass area / Freie Glasichtfläche

Rozměry v mm
Dimensions in mm
Maße in mm

Heat L 3g L 50.51.40.21
+ H2 AIRBOX 01
190kg

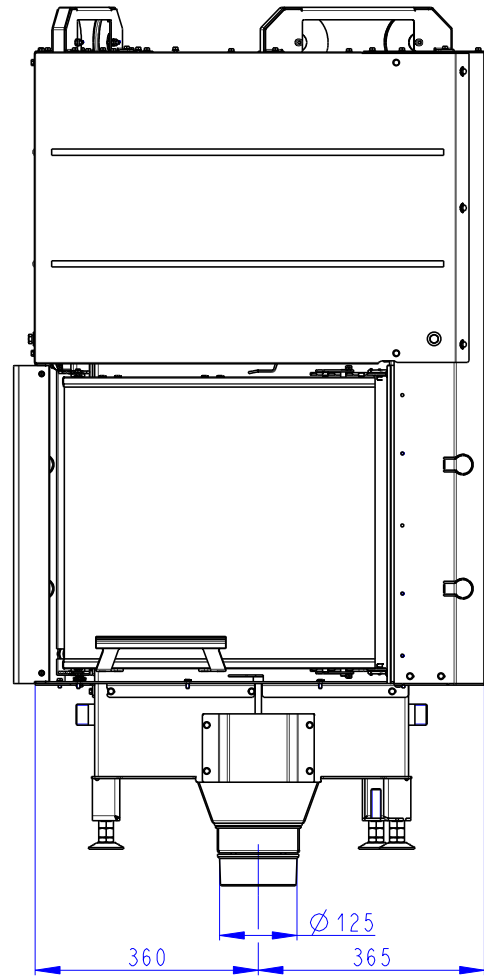
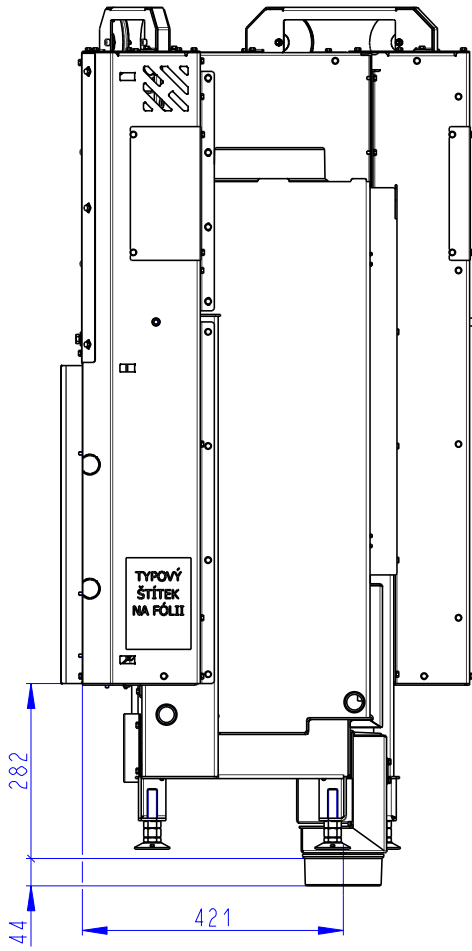

Rozmery v mm
Dimensions in mm
Maße in mm

Heat L 3g L 50.51.40.21
+ HL3LE KON 01
200kg

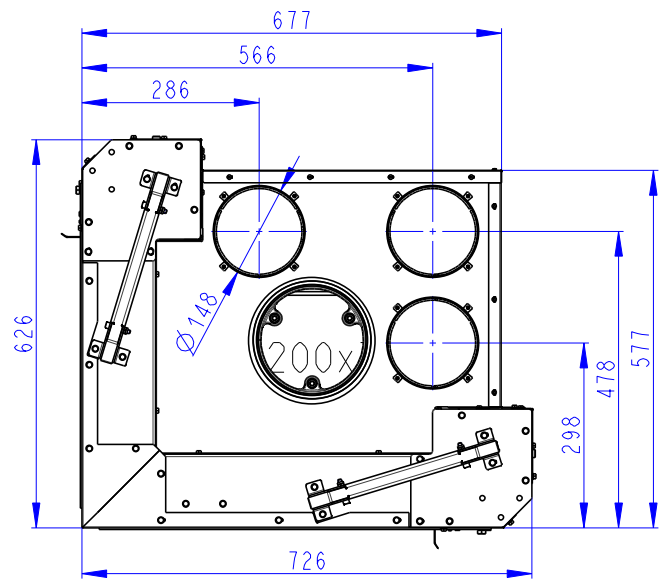
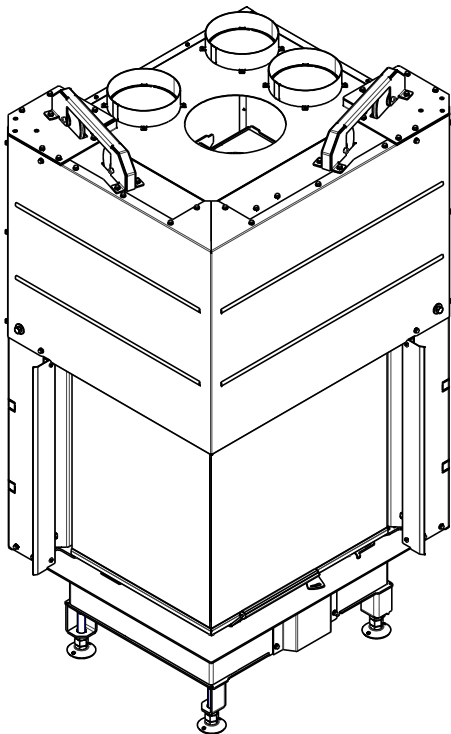
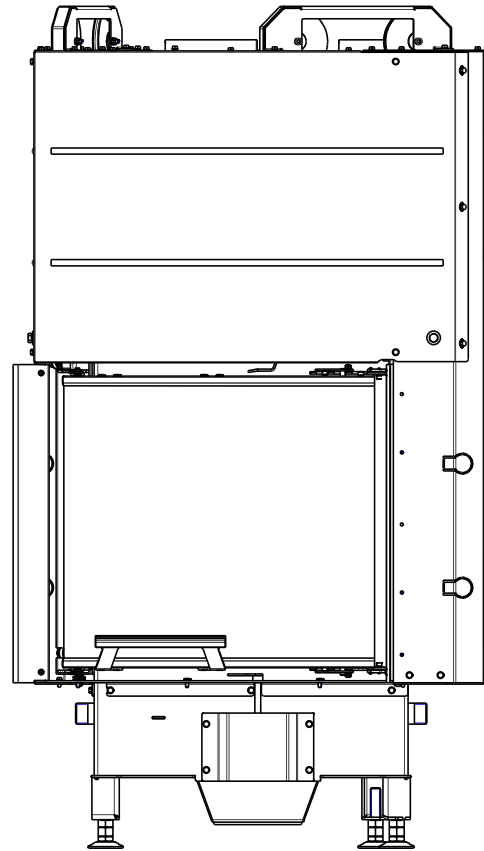
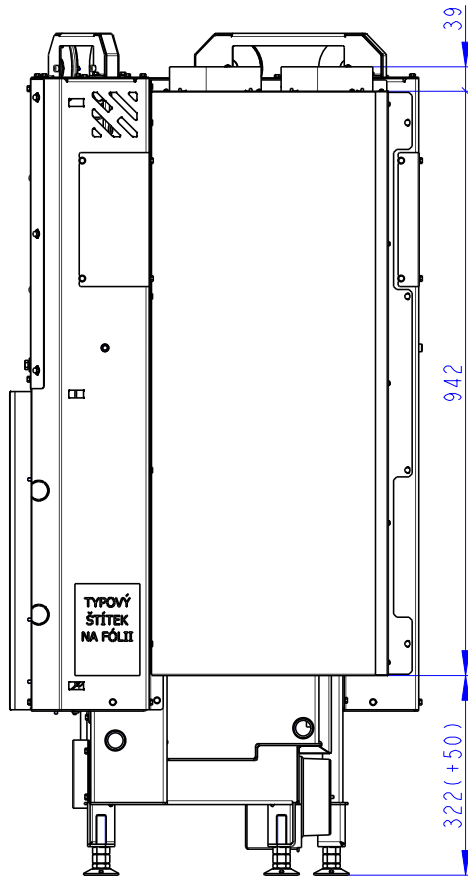

NELZE KOMBINOVAT SE SADAMI AKUMULACI AKKUM KV 02, AKKUM KV 05
UNABLE TO COMBINE WITH ACCUMULATION SETS AKKUM KV 02, AKKUM KV 05
NICHT KOMBINIERBAR MIT SPEICHERSATZ AKKUM KV 02, AKKUM KV 05

Rozměry v mm
Dimensions in mm
Maße in mm

Heat L 3g L 50.51.40.21
+ AKKUM KV 02
280kg

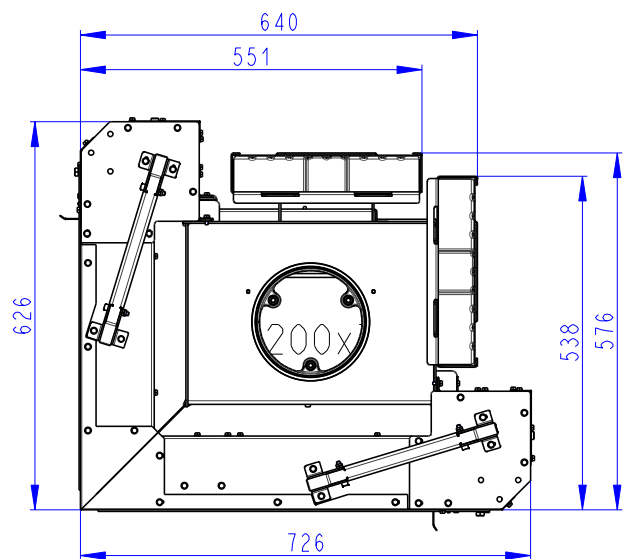
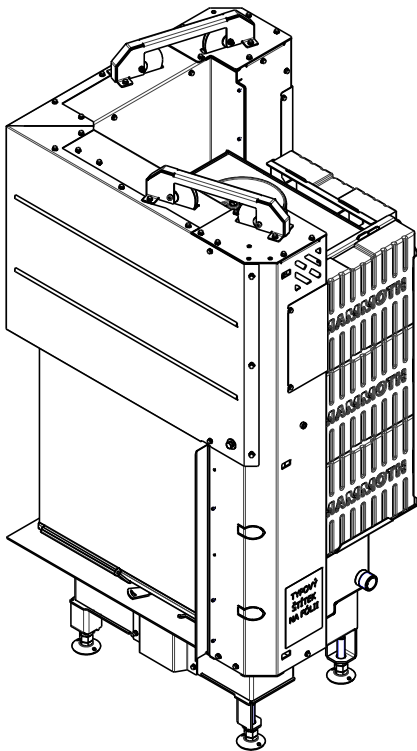
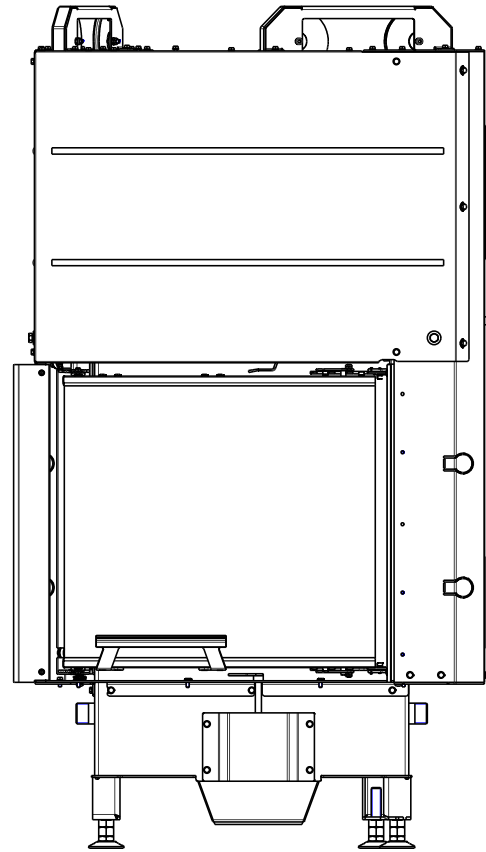
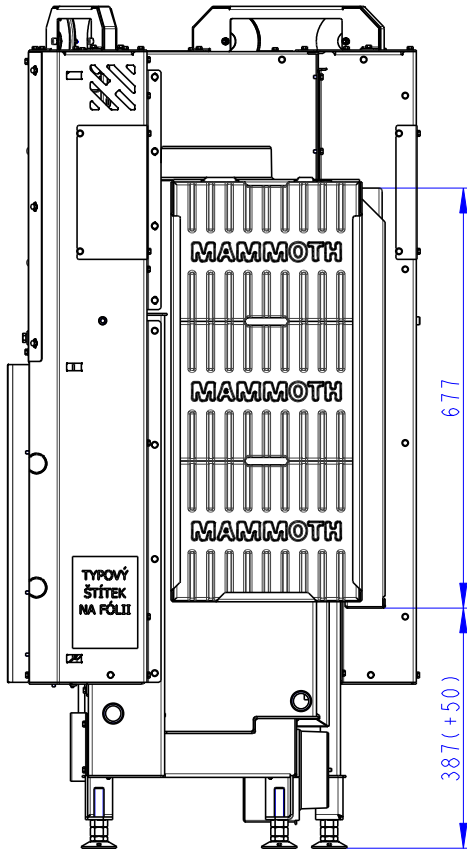

Rozmery v mm
Dimensions in mm
Maße in mm

Heat L 3g L 50.51.40.21
+ AKKUM KV 05
260kg

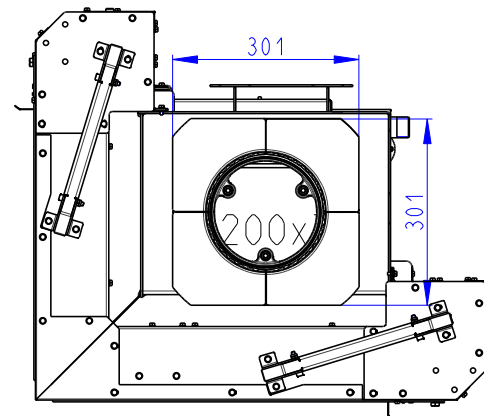
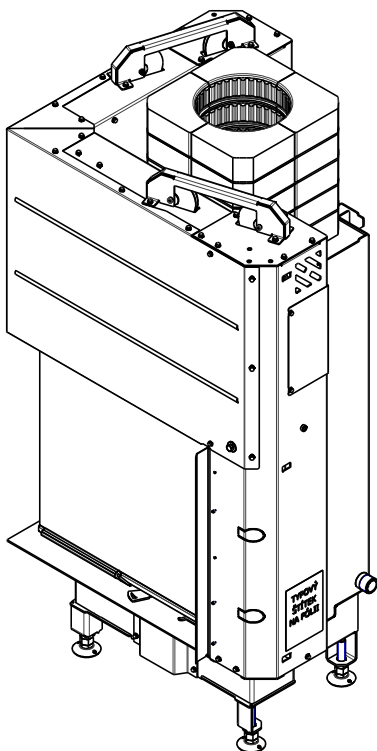
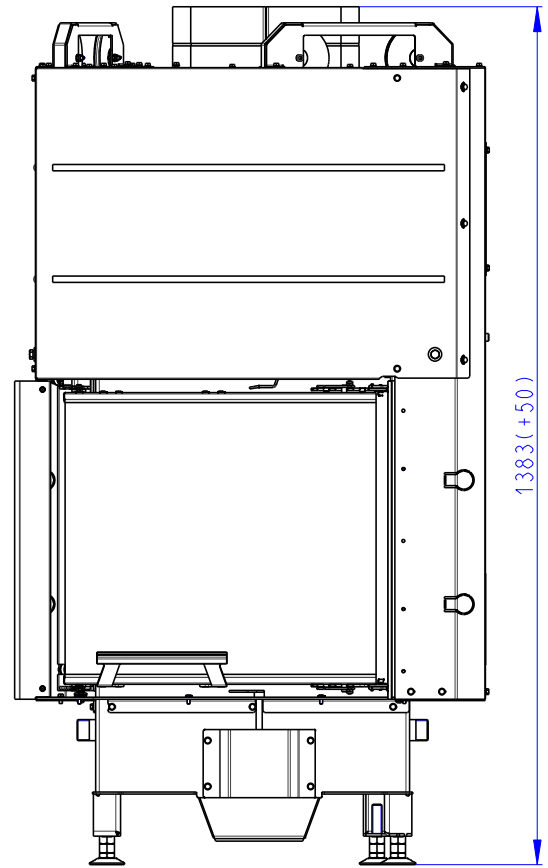
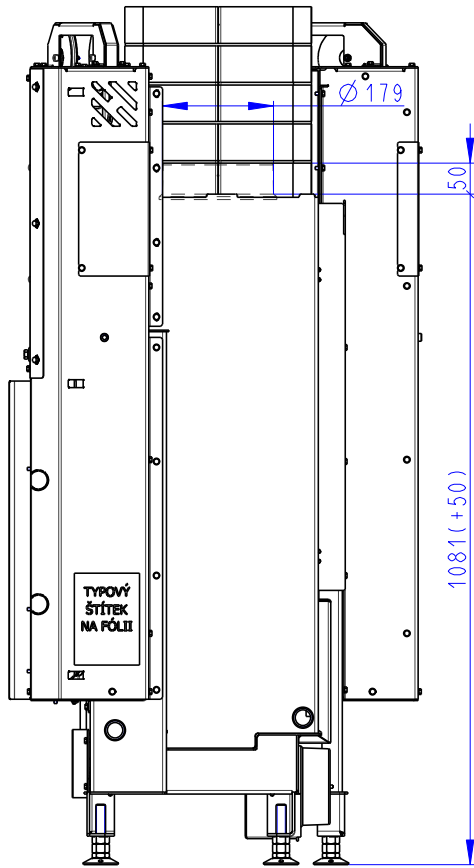

Rozměry v mm
 Dimensions in mm
 Maße in mm

Heat L 3g L 50.51.40.21
 + HL3LE RAM11
 190kg

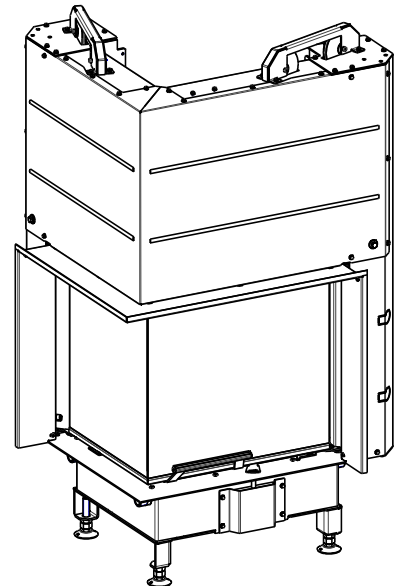
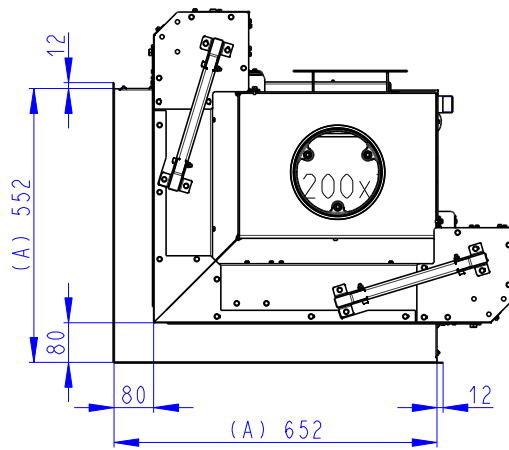
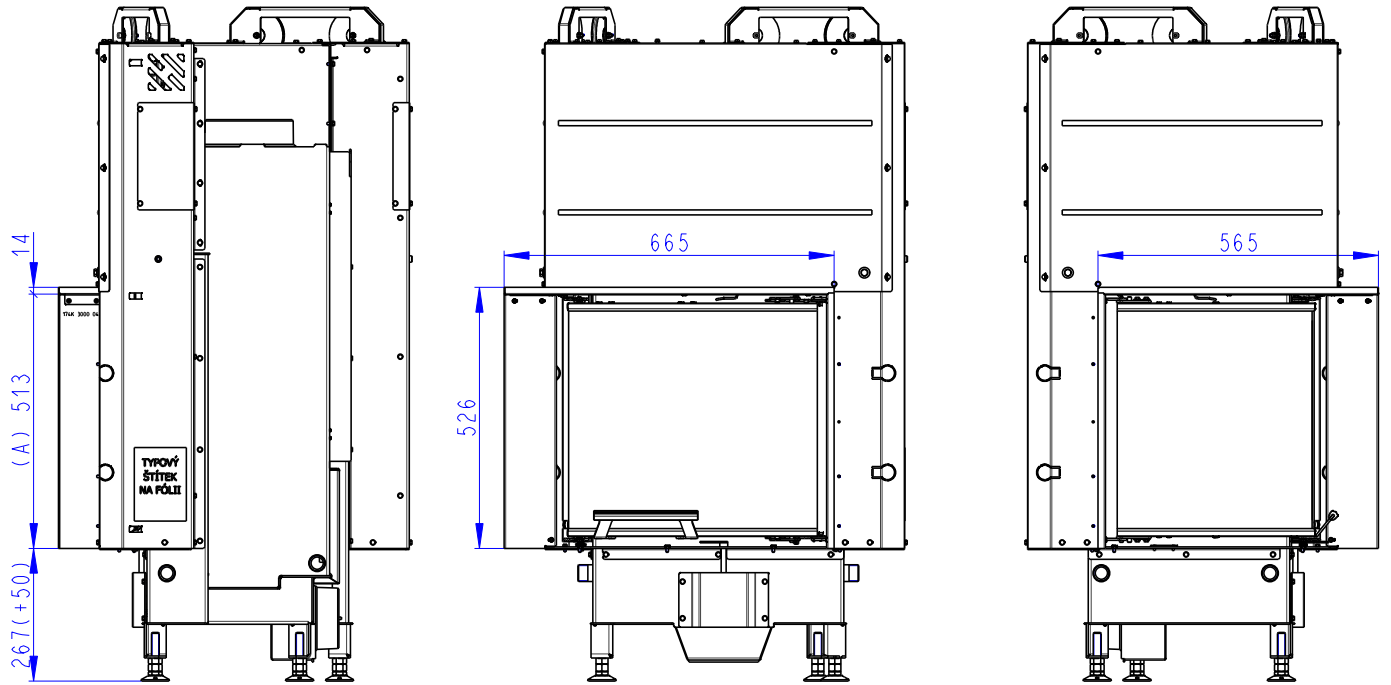

- (A) Zastavbovy rozmer / In-built dimension / Baumaße
- (B) Litinový odvod kouře / Cast iron spigot / Der gusseiserne Rauchabgang
- (C) Centralní privod vzduchu / Central air inlet / Zentralluftzufuhr
- (D) Primární a sekundární vzduch / Primary and secondary air / Primärluft und Sekundärluft
- (L) Volná plocha prosklení / Free glass area / Freie Glassichtfläche

Rozměry v mm
Dimensions in mm
Maße in mm

Heat L 3g L 50.51.40.21
+ HL3LE RAM12
195kg

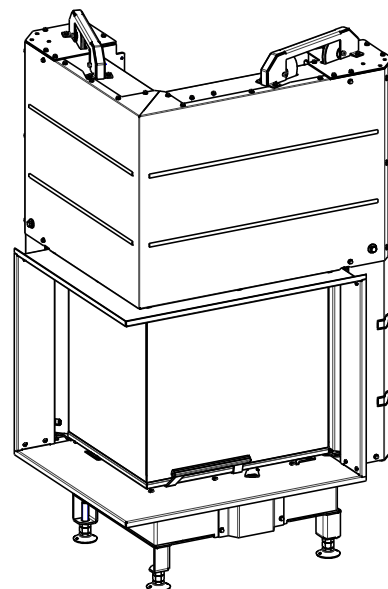
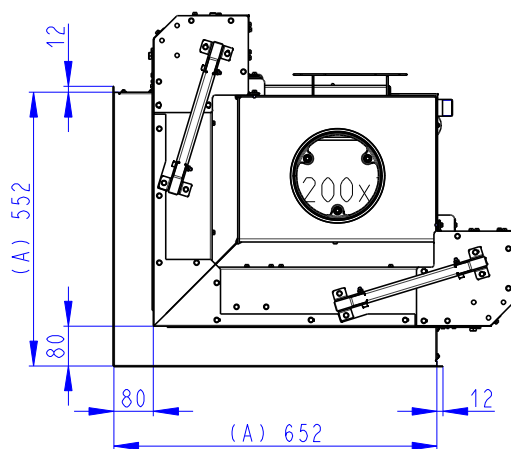
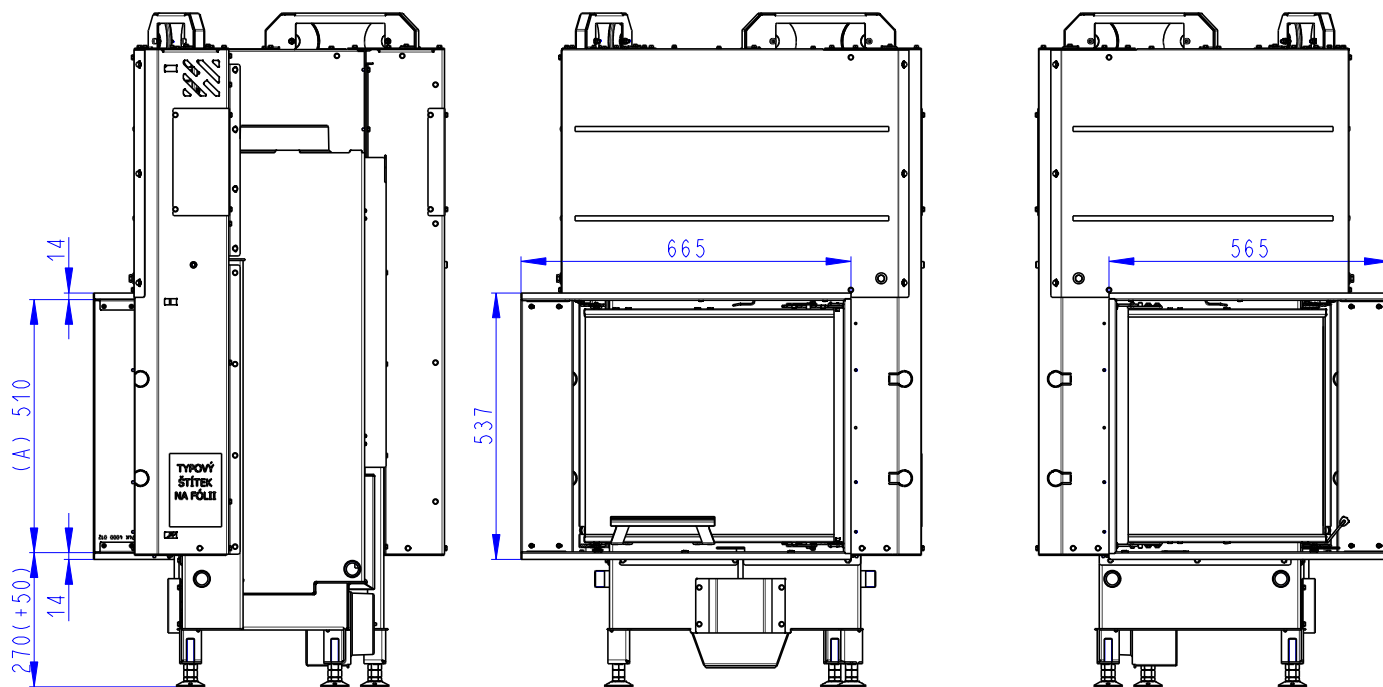

- (A) Zastavbovy rozmer / In-built dimension / Baumaße
- (B) Litinový odvod kouře / Cast iron spigot / Der gusseiserne Rauchabgang
- (C) Centralní privod vzduchu / Central air inlet / Zentralluftzufuhr
- (D) Primární a sekundární vzduch / Primary and secondary air / Primärluft und Sekundärluft
- (L) Volná plocha prosklení / Free glass area / Freie Glassichtfläche

Rozměry v mm
 Dimensions in mm
 Maße in mm

Heat L 3g L 50.51.40.21
 + HR3LE RAM13
 205kg

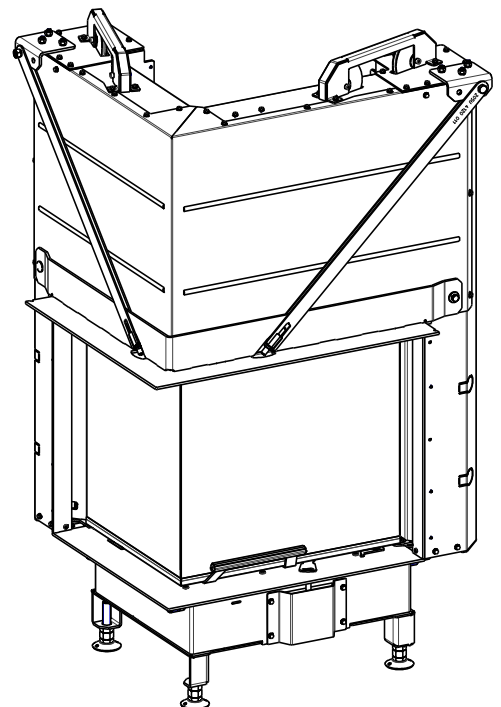
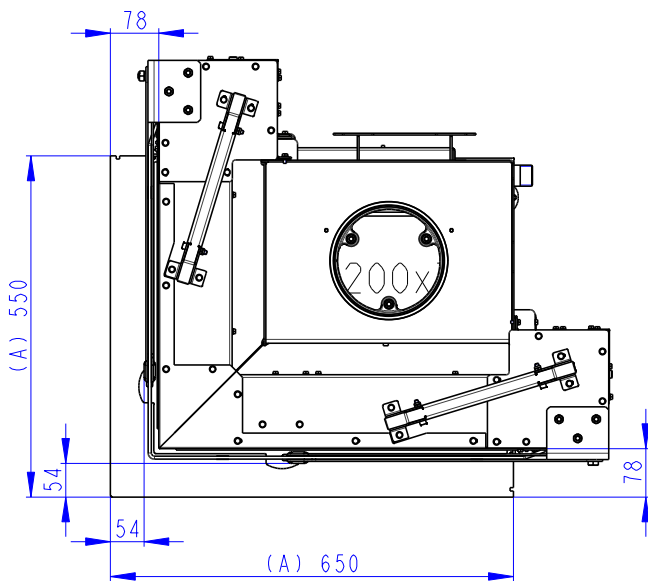
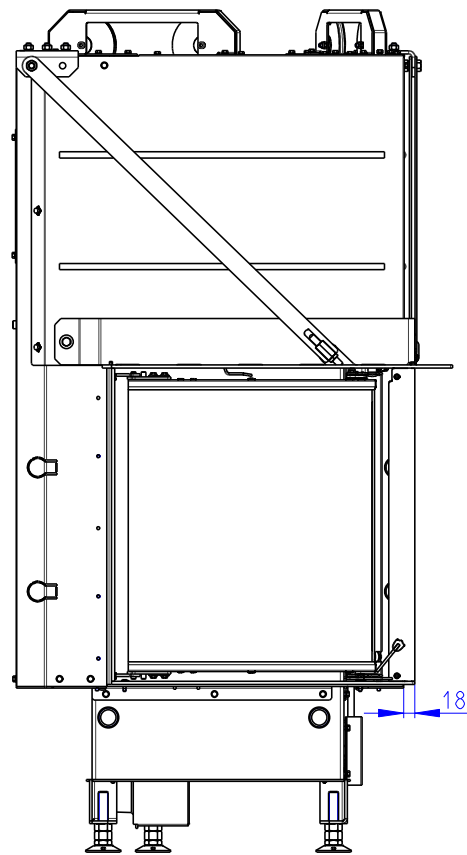
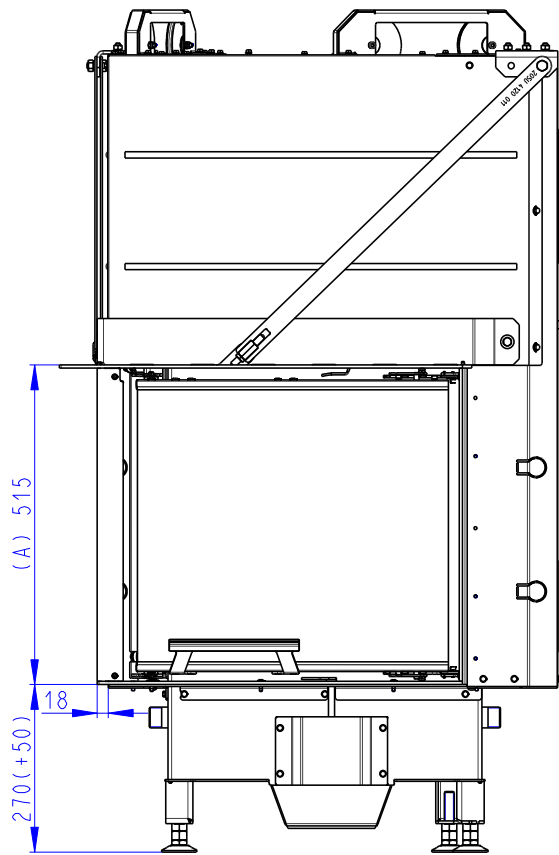

- (A) Zastavbovy rozmer / In-built dimension / Baumaße
- (B) Litinový odvod kouře / Cast iron spigot / Der gusseiserne Rauchabgang
- (C) Centrální privod vzduchu / Central air inlet / Zentralluftzufuhr
- (D) Primární a sekundární vzduch / Primary and secondary air / Primärluft und Sekundärluft
- (L) Volná plocha prosklení / Free glass area / Freie Glassichtfläche

Rozměry v mm
 Dimensions in mm
 Maße in mm

Heat L 3g L 50.51.40.21
 + HR3LE RAM14
 210kg

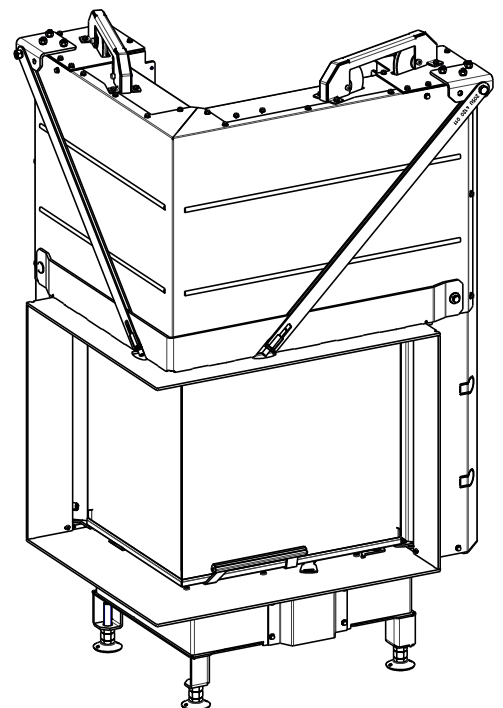
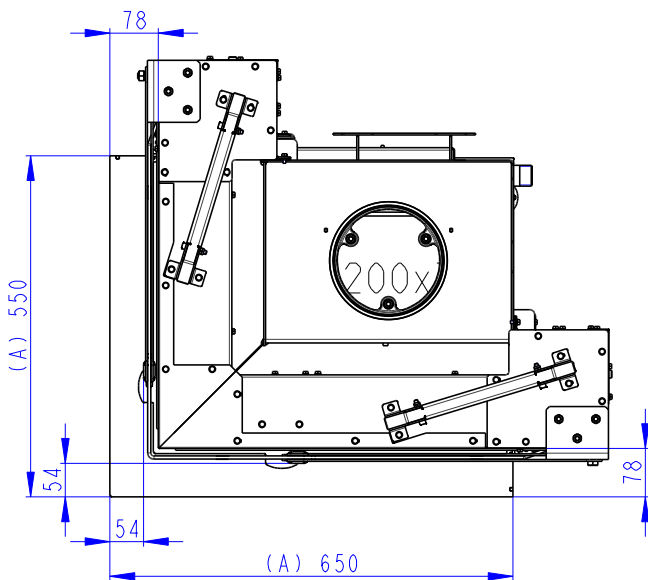
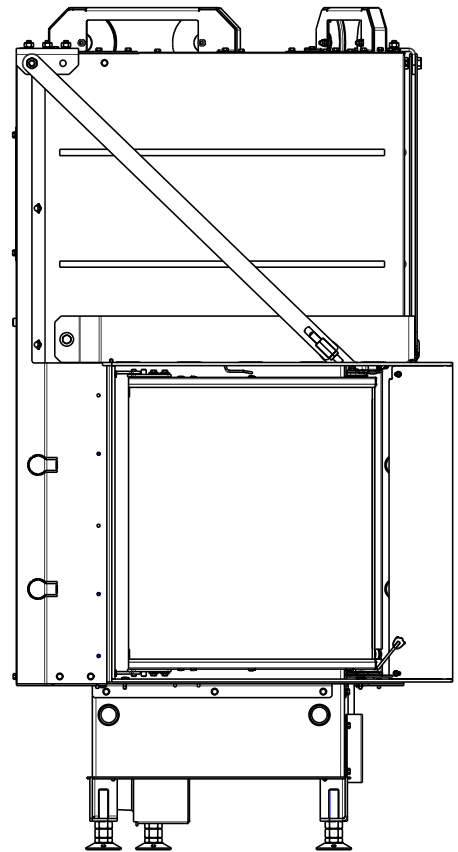
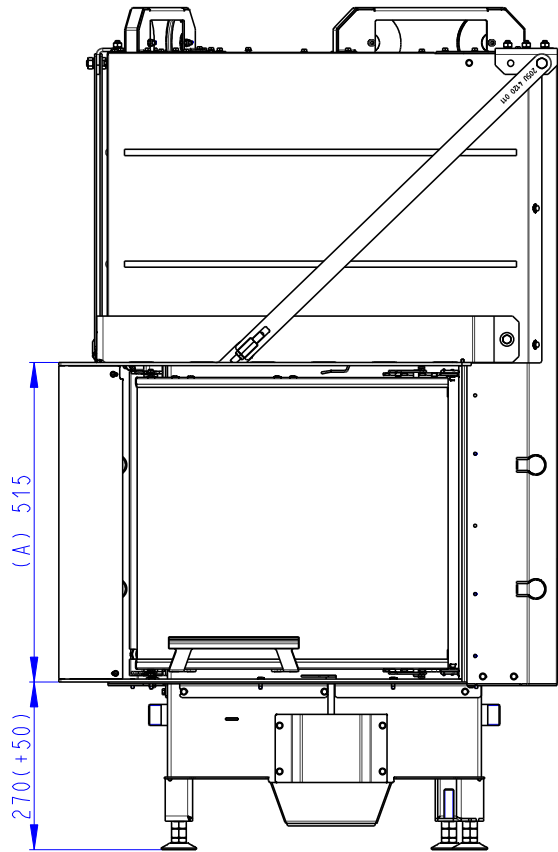

- (A) Zastavbovy rozmer / In-built dimension / Baumaße
 (B) Litinový odvod kouře / Cast iron spigot / Der gusseiserne Rauchabgang
 (C) Centrální privod vzduchu / Central air inlet / Zentralluftzufuhr
 (D) Primární a sekundární vzduch / Primary and secondary air / Primärluft und Sekundärluft
 (L) Volná plocha prosklení / Free glass area / Freie Glassichtfläche

Rozměry v mm
Dimensions in mm
Maße in mm

Heat R 3g L 50.51.40.21
190kg

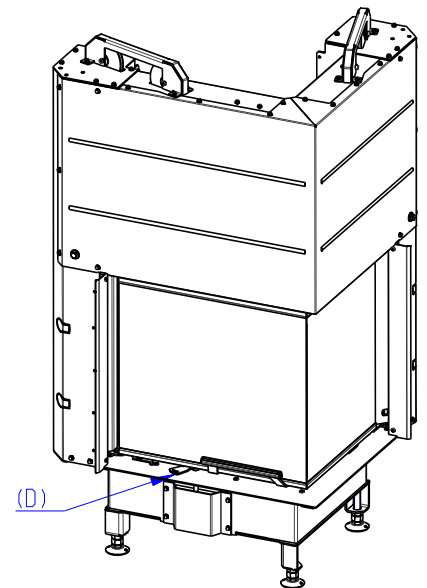
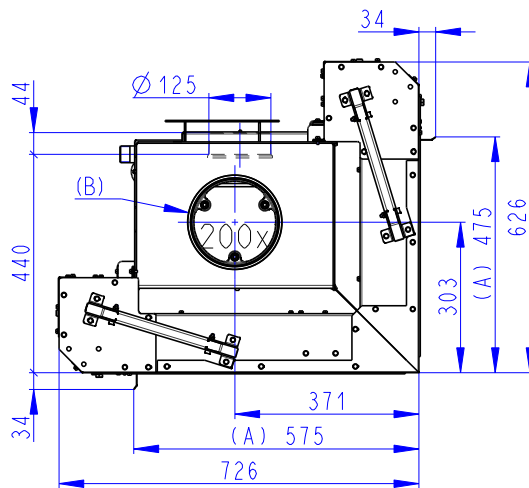
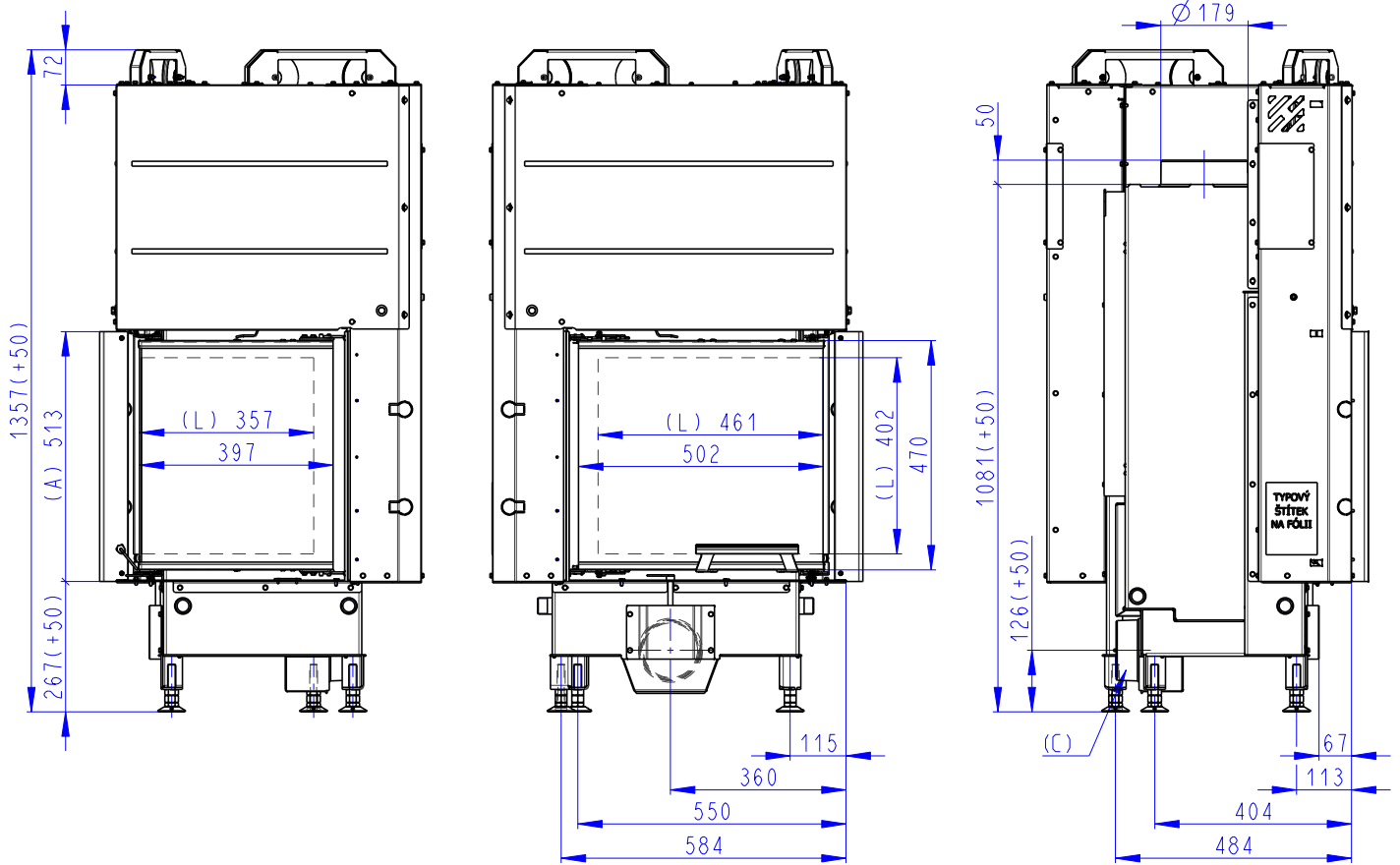

- (A) Zastavbovy rozmer / In-built dimension / Baumaße
 (B) Litinový odvod kouře / Cast iron spigot / Der gusseiserne Rauchabgang
 (C) Centralní přívod vzduchu / Central air inlet / Zentralluftzufuhr
 (D) Primární a sekundární vzduch / Primary and secondary air / Primärluft und Sekundärluft
 (L) Volná plocha prosklení / Free glass area / Freie Glassichtfläche

Rozmery v mm
Dimensions in mm
Maße in mm

Heat R 3g L 50.51.40.21
+ H2 AIRBOX 01
190kg

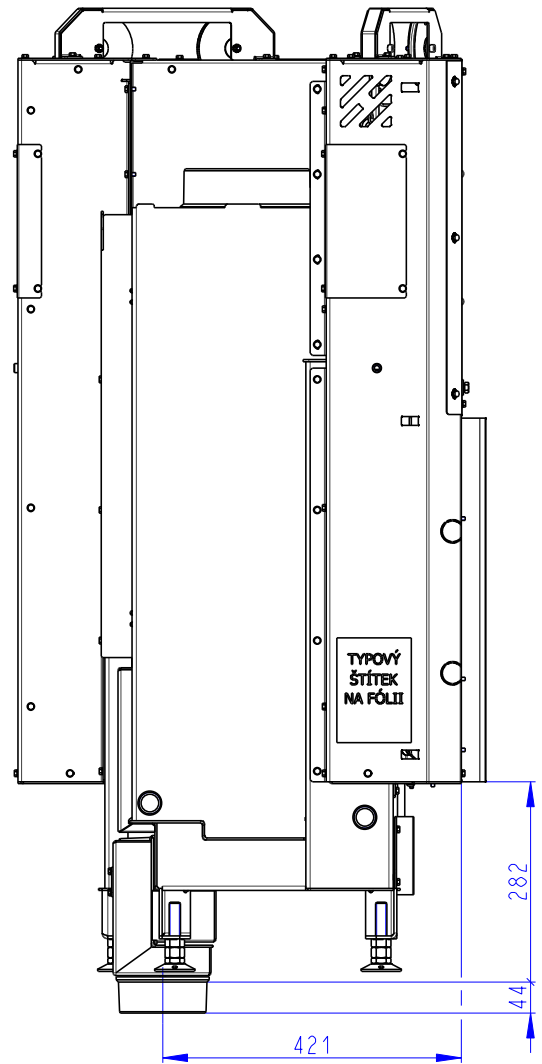
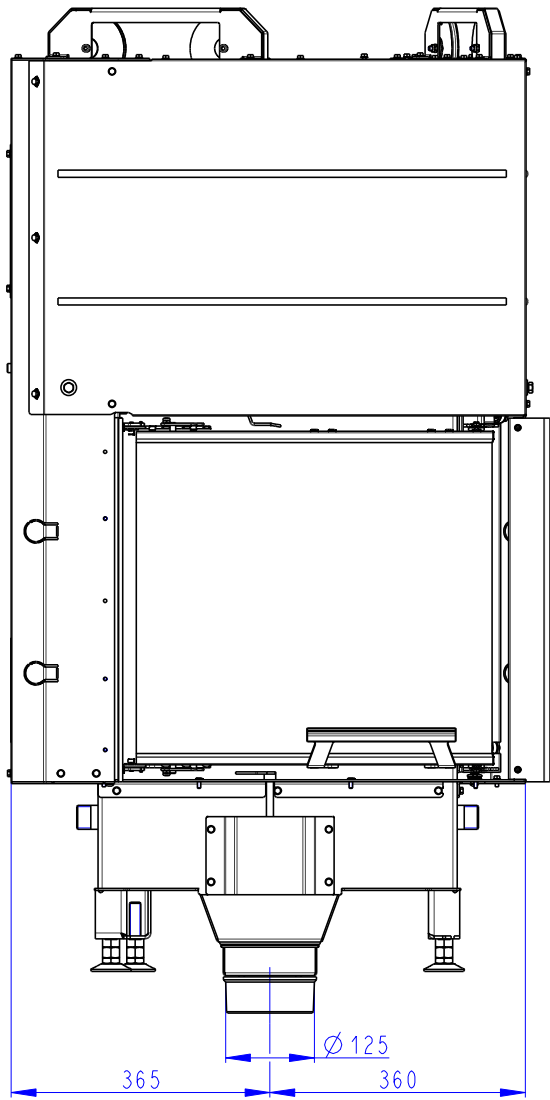

Rozmery v mm
Dimensions in mm
Maße in mm

Heat R 3g L 50.51.40.21
+ HR3LE KON 01
200kg

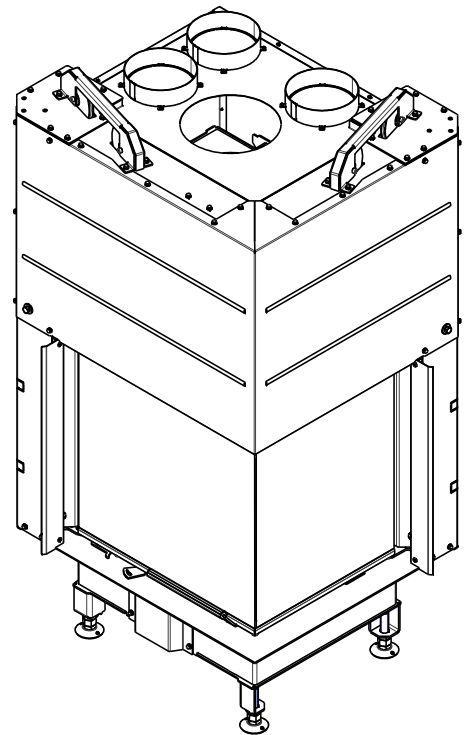
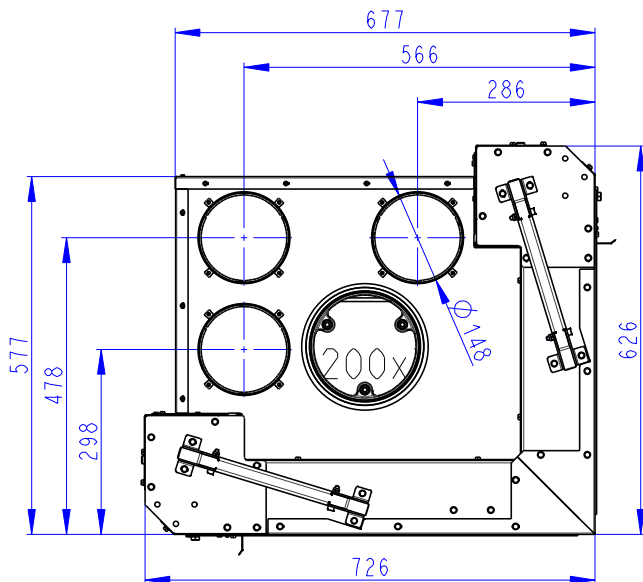
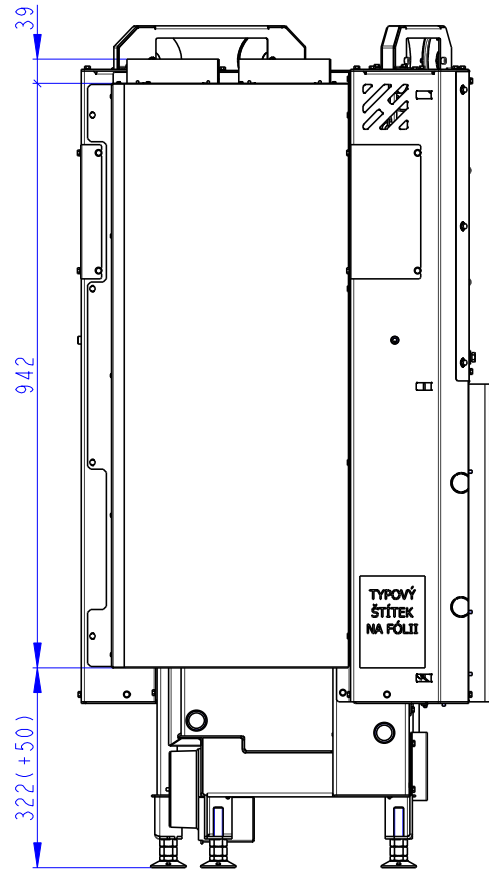
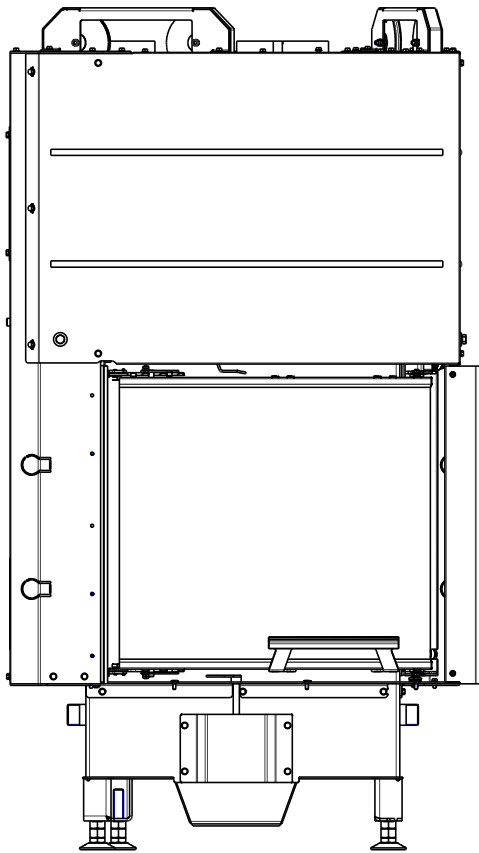

NELZE KOMBINOVAT SE SADAMI AKUMULACI AKKUM KV 02, AKKUM KV 05
UNABLE TO COMBINE WITH ACCUMULATION SETS AKKUM KV 02, AKKUM KV 05
NICHT KOMBINIERBAR MIT SPEICHERSATZ AKKUM KV 02, AKKUM KV 05

Rozmery v mm
Dimensions in mm
Maße in mm

Heat R 3g L 50.51.40.21
+ AKKUM KV 02
280kg

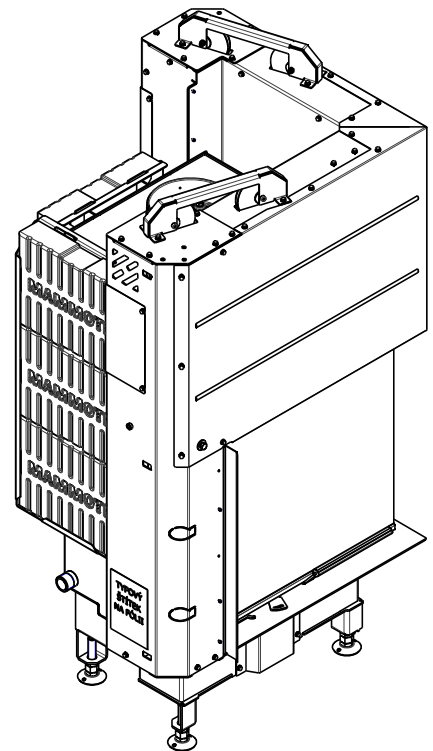
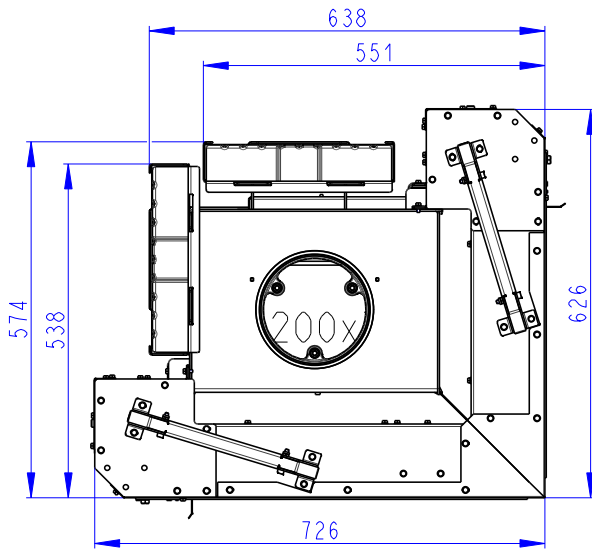
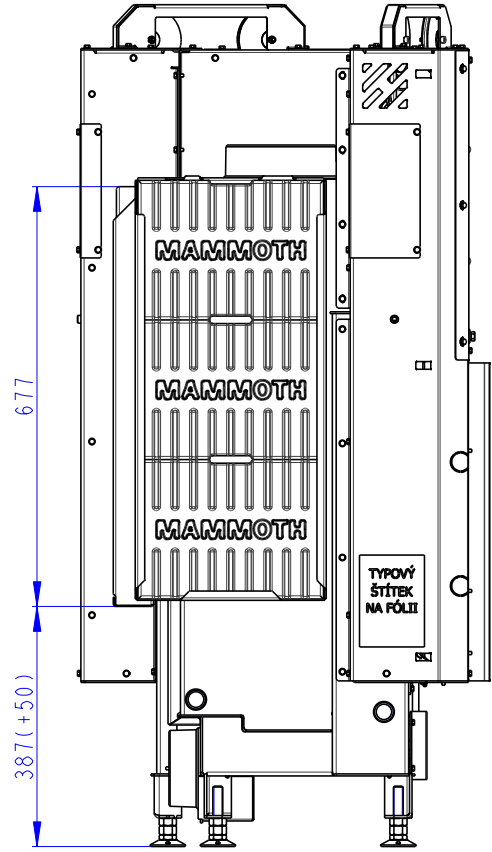
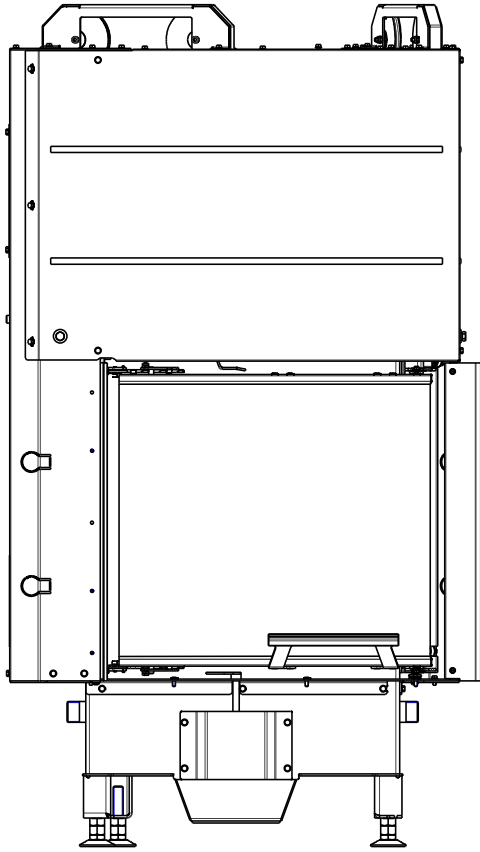

Rozměry v mm
Dimensions in mm
Maße in mm

Heat R 3g L 50.51.40.21
+ AKKUM KV 05
260kg

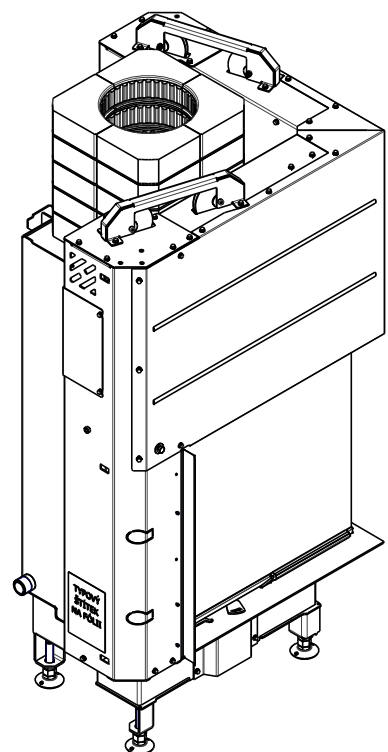
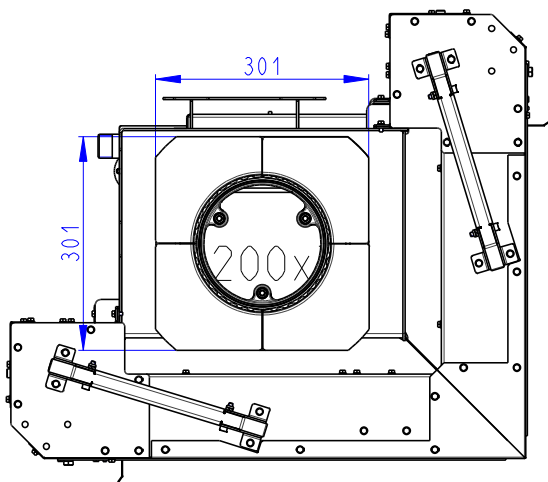
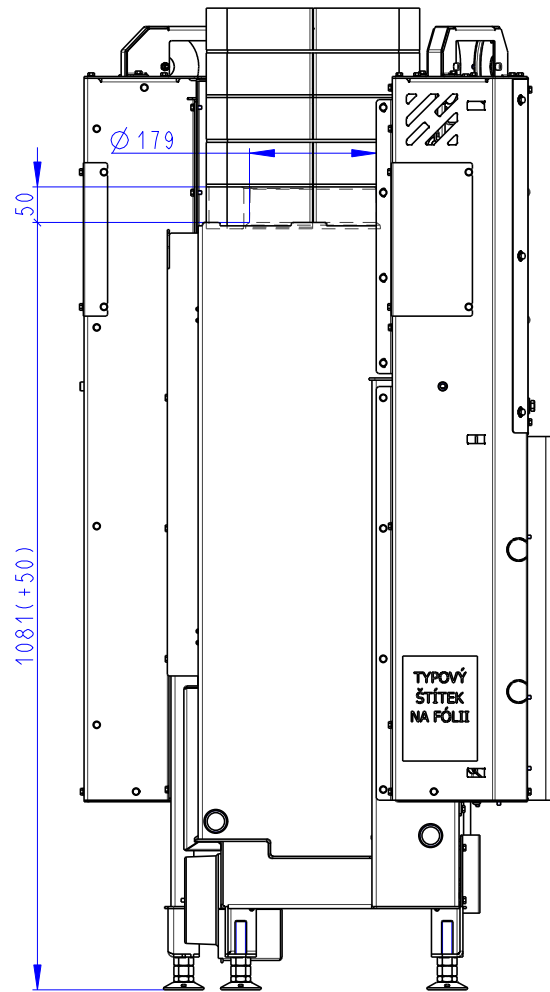
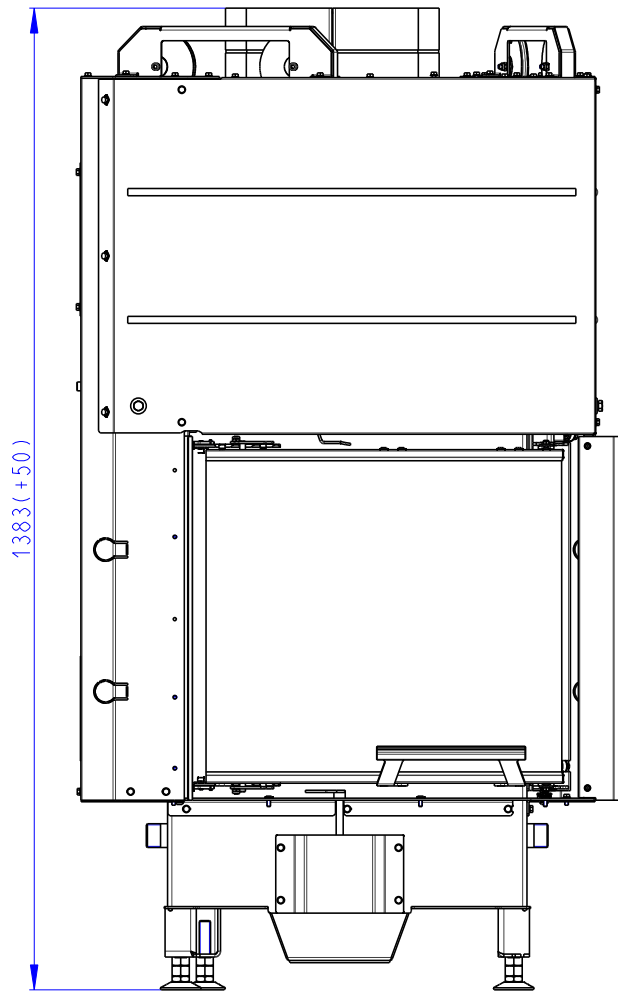

Rozměry v mm
Dimensions in mm
Maße in mm

Heat R 3g L 50.51.40.21 + HR3LE RAM11

190kg

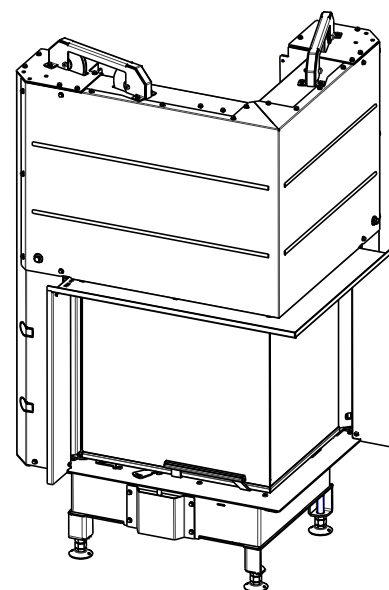
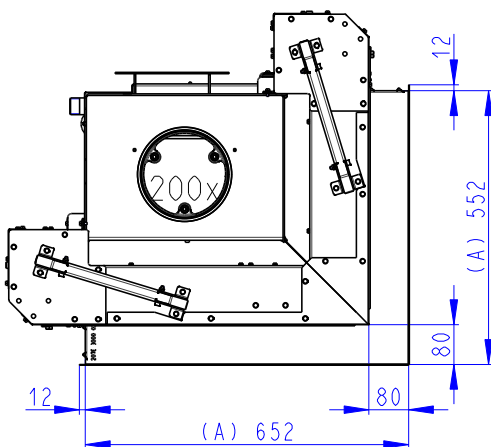
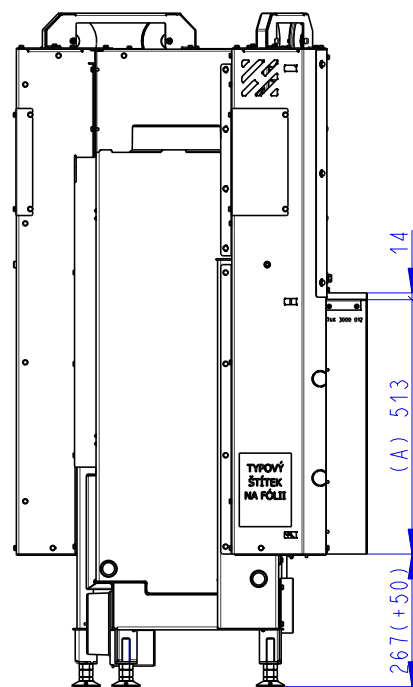
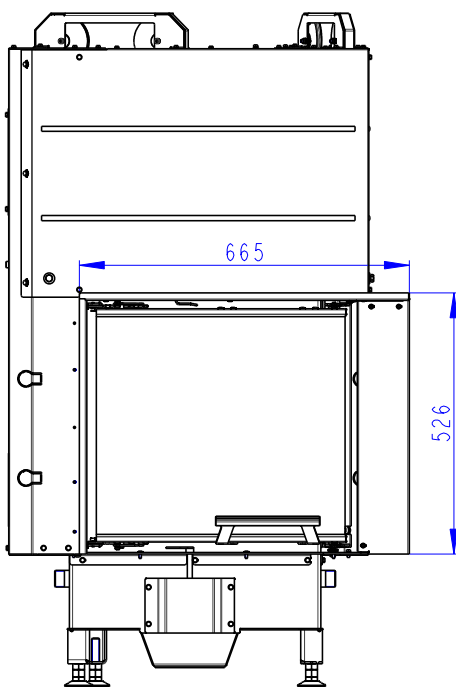
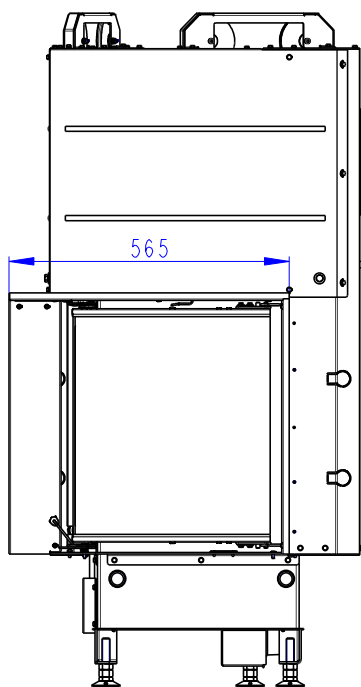

- (A) Zastavbovy rozmer / In-built dimension / Baumaße
- (B) Litinový odvod kouře / Cast iron spigot / Der gusseiserne Rauchabgang
- (C) Centrální privod vzduchu / Central air inlet / Zentralluftzufuhr
- (D) Primární a sekundární vzduch / Primary and secondary air / Primärluft und Sekundärluft
- (L) Volná plocha prosklení / Free glass area / Freie Glassichtfläche

Rozměry v mm
 Dimensions in mm
 Maße in mm

Heat R 3g L 50.51.40.21
 + HR3LE RAM12
 195kg

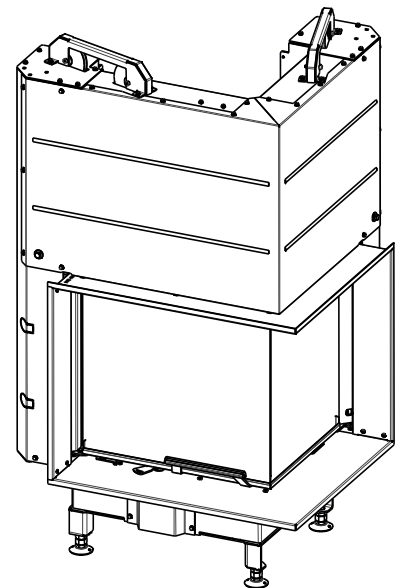
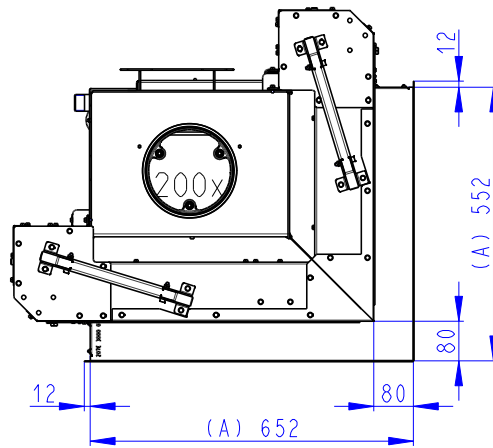
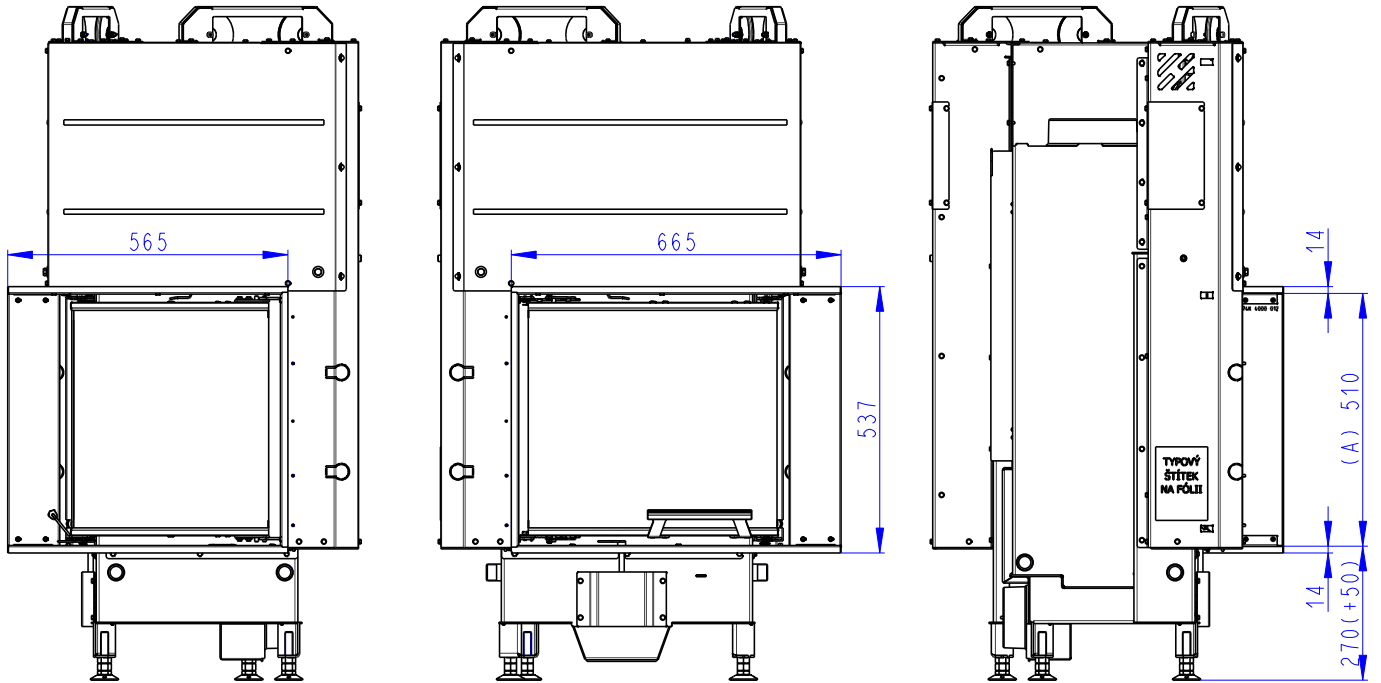

- (A) Zastavbovy rozmer / In-built dimension / Baumaße
- (B) Litinový odvod kouře / Cast iron spigot / Der gusseiserne Rauchabgang
- (C) Centrální privod vzduchu / Central air inlet / Zentralluftzufuhr
- (D) Primární a sekundární vzduch / Primary and secondary air / Primärluft und Sekundärluft
- (L) Volná plocha prosklení / Free glass area / Freie Glassichtfläche

Rozmery v mm
 Dimensions in mm
 Maße in mm

Heat R 3g L 50.51.40.21
 + HR3LE RAM13
 205kg

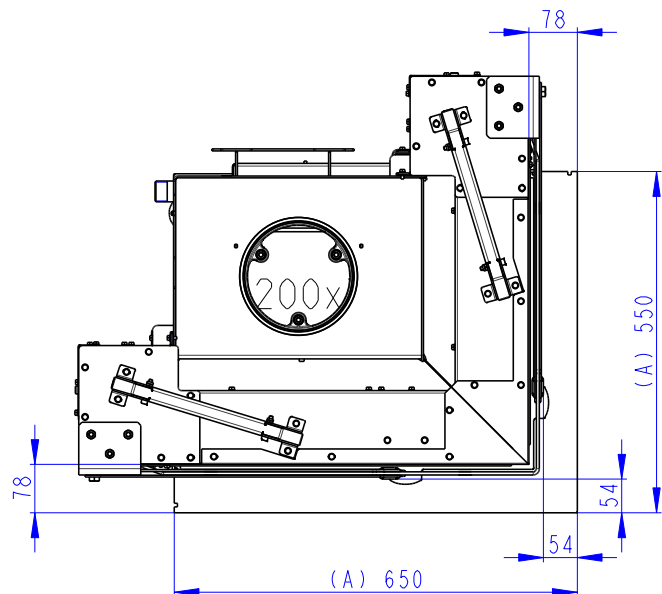
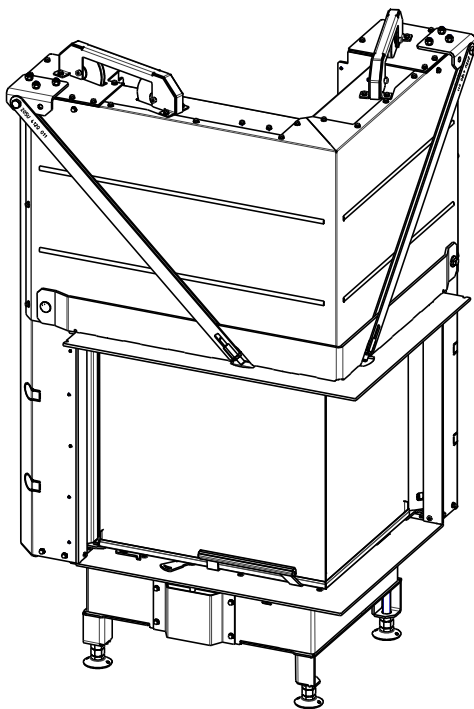
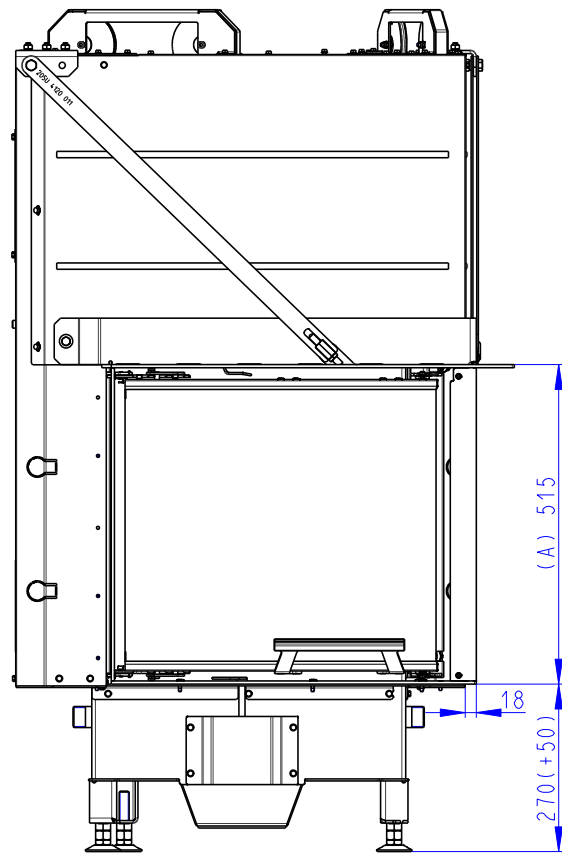
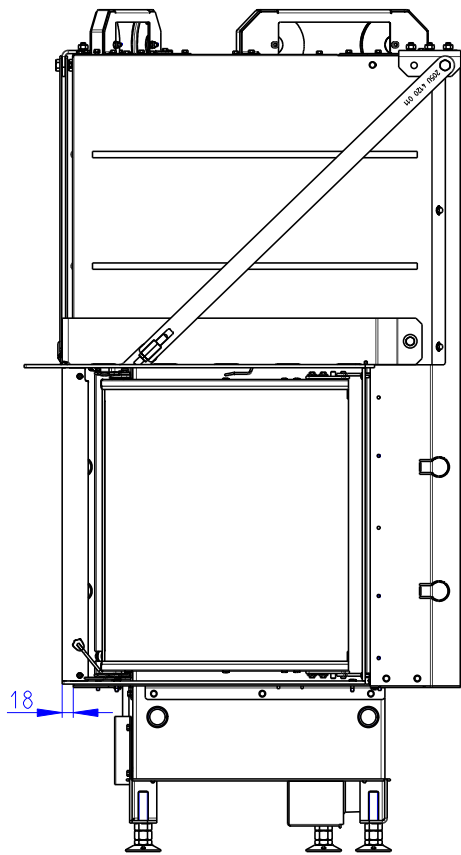

- (A) Zastavbovy rozmer / In-built dimension / Baumaße
- (B) Litinový odvod kouře / Cast iron spigot / Der gusseiserne Rauchabgang
- (C) Centralní privod vzduchu / Central air inlet / Zentralluftzufuhr
- (D) Primární a sekundární vzduch / Primary and secondary air / Primärluft und Sekundärluft
- (L) Volná plocha prosklení / Free glass area / Freie Glassichtfläche

Rozměry v mm
 Dimensions in mm
 Maße in mm

Heat R 3g L 50.51.40.21
 + HR3LE RAM14
 210kg

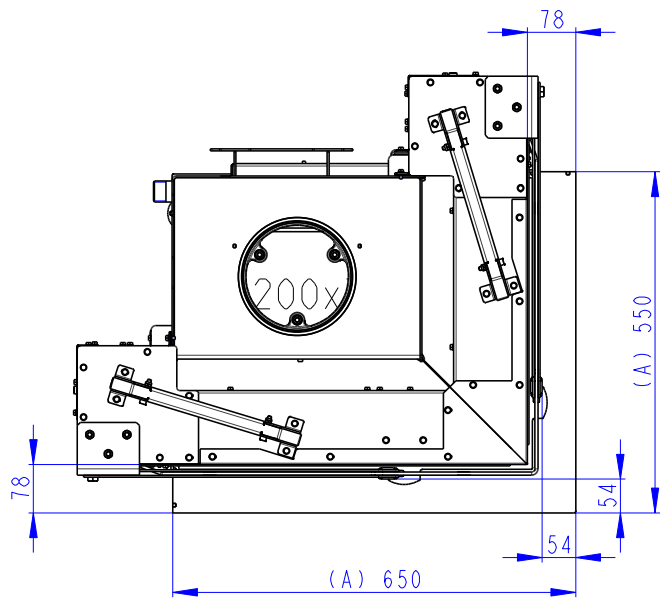
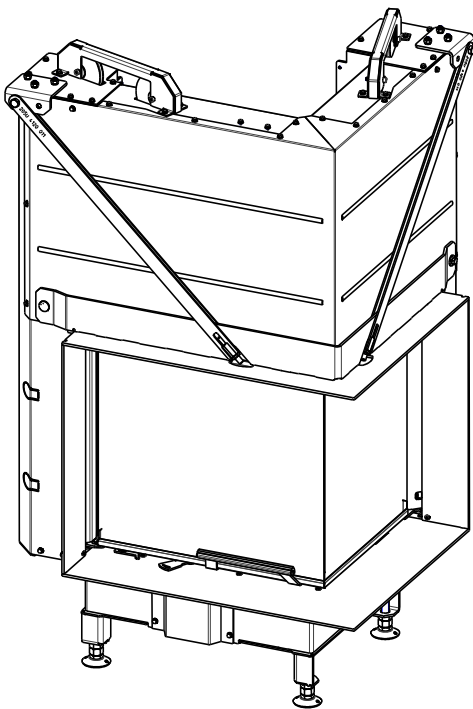
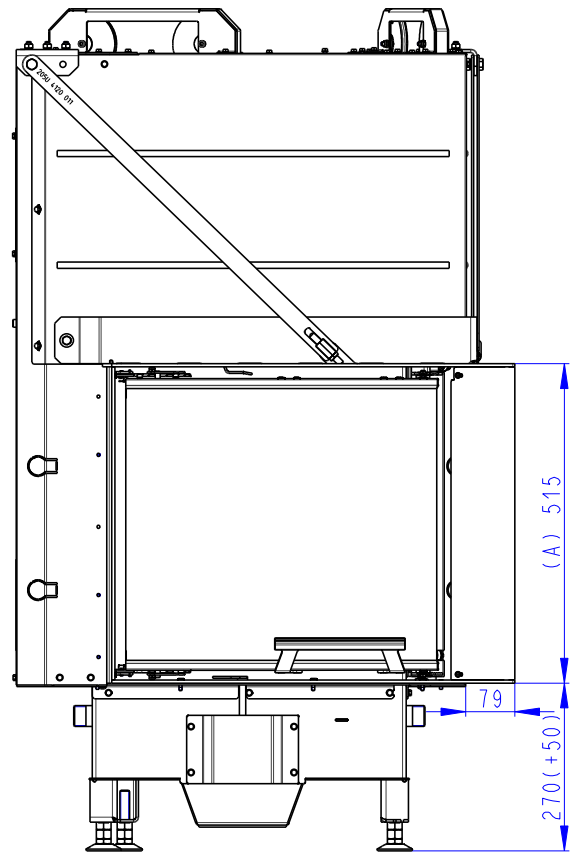
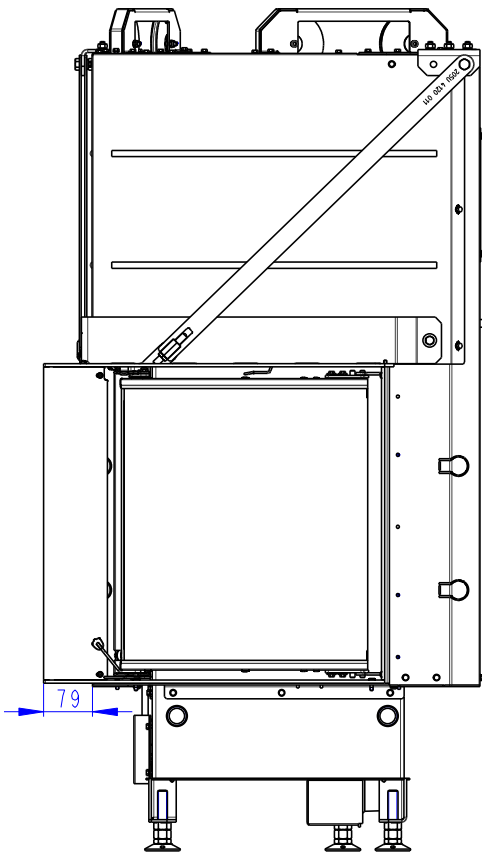

- (A) Zastavbovy rozmer / In-built dimension / Baumaße
- (B) Litinový odvod kouře / Cast iron spigot / Der gusseiserne Rauchabgang
- (C) Centralni privod vzduchu / Central air inlet / Zentralluftzufuhr
- (D) Primarni a sekundarni vzduch / Primary and secondary air / Primärluft und Sekundärluft
- (L) Volna plocha prosklení / Free glass area / Freie Glassichtfläche