

Declared qualities stated

Harmonised technical specification	EN 13240 ✓ EN 13229	EN 16510 ✓ Ecodesign	✓ DIN+ ✓ BImSchV2	DIBt ✓ 15a B-VG 2015
Classification of appliance	Type BE			
Energy efficiency (η_{nom})	80,2 %			
The energy efficiency index	106,3			
Energy label	A			
Fuel	Wood logs			
Fuel length	200-330 mm			
Average fuel consumption	2,81 kg/h			
Allowed fuel dose	3,7 kg/h			
Fuel supply interval	1 hour			
Amount of combustion air	35,6 m ³ /h			
Nominal output (P_{nom})	9,7 kW			
Hot-water exchanger output (P_{Wnom})	---			
Maximum operating overpressure (p_w)	---			
Dry flue gas mass flow rate to calculate the flue gas path	8,8 g/s			
Flue gas temperature (T_{nom})	248 °C			
Mean flue gas temperature after throat	286 °C			
Flue draught (p_{nom})	12 Pa			
Chimney temperature class	T400			
Connection to the common chimney	No			
Storage of fuel in the wood shed area	No			
Maximum warming of the wood in the wood shed	---			
Dust O ₂ = 13 % (PM_{nom})	20 mg/Nm ³			
Emissions of gases of combustion (CO in the flue gases at O ₂ = 13 %) (CO_{nom})	0,0789 % 986 mg/Nm ³			
OGC O ₂ = 13 % (OGC_{nom})	44 mg/Nm ³			
NO _x O ₂ = 13 % (NO_{xnom})	114 mg/Nm ³			
Automatic regulation unit of burning	---			
Power consumption (W)	---			
Standing air loss (V _h)	---			
Intermittent operation (INT) / Continuous operation (CON)	INT			

Basic technical data

Principal dimensions Height (H) Width (W) Length (L)	1354 848 447	mm
Combustion chamber dimensions Height (H) Width (W) Length (L)	472 599 237	mm
Fireplace door dimensions Height (H) Width (W) Length (L)	556 629 ---	mm
Axis height of the rear (side) outlet	1181	mm
Volume of hot-water exchanger	---	l
Flue diameter	160-180	mm
Diameter of flue throat (D_{out})	180	mm
Diameter of external air connection	150	mm
Weight	134	kg
Area of Inlet ventilation grille	700	cm ²
Area of Outlet ventilation grille	900	cm ²

Operation with connected accumulating mass

Minimal active radiant surface	4,5	m ²
Average flue gas temperature before / after	398 ---	°C
Maximum fuel dose	6,8	kg
Output of chamber	22,0	kW
Reloading interval	---	hod
Maximum fuel dose (set interval)	---	6,8 kg
Average hourly output	---	kW

The fireplace insert is suitable for use in radiant fireplaces without convection grilles if the stove rules and regulations are followed. Fire protection / insulation boards for radiant cladding without convection grille made of nonflammable material with a thermal conductivity $\leq 1,1 \text{ W} \cdot \text{m}^{-1} \cdot \text{K}^{-1}$ (λ).

Distances from flammable materials
Note

Back (d_R)	800	mm
Front (d_P)	1000	mm
Front to the floor (d_F)	---	mm
Side (d_S)	*	500 mm
Side with glass (d_{S1})	---	mm
Side – niche (d_{S2})	---	mm
Side – location 45° (d_{S3})	---	mm
Side radiation (d_L)	---	mm
From the floor (d_B)	---	mm
From the ceiling (d_C)	1000	mm
From the back and side edge of the fireplace insert to the inside of the insulation (d_{S4})	*	120 mm

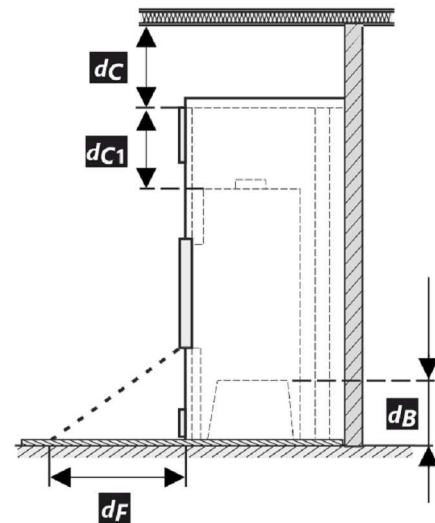
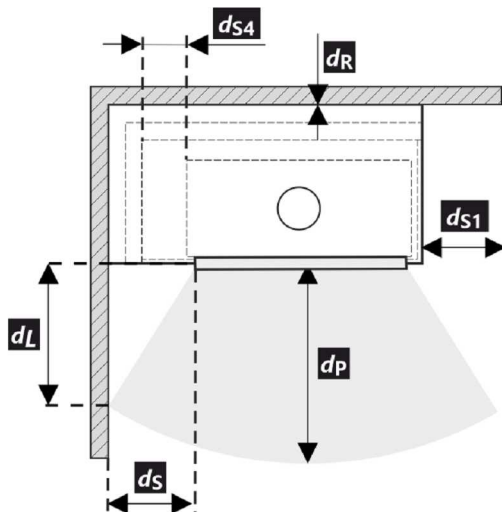

All local regulations, including regulations relating to national and European standards, must be observed during the installation and operation of the product.

- * If the distance from the door glass to the combustible side wall is $d_S < 500 \text{ mm}$ and must not be $d_{S4} < 120 \text{ mm}$, this wall must be protected by a 40 mm wide SILCA 250 insulation board or an adequate substitute.

Legend	Note	Description	Material	Dimension
1		Appliance	205J 0000 002	
2		Flue gas outlet	metal	DN160-180
3		Insulation of the flue gas connection		
4		Mineral insulation		
5		Convection air space around the appliance		
6		Protective insulation of walls	SILCA 250	2x50 mm
6A		Protective ceiling insulation	SILCA 250	80 mm
7		Protective wall	hollow burnt brick	100 mm
8		Combustible wall		
9		Concrete slab		
10		Combustible floor		
11		Decorative / ornamental beam		
12		Beam with ventilation air gap		
13		Convection air inlet		700 cm ²
14		Convection air outlet		900 cm ²
15		Lining	SILCA 250	40 mm
16		Support frame		
17		Combustible ceiling		
18		Protective insulation board for combustible floors	SILCA 250	40 mm
19		Combustion air regulation		
20		Sheet metal cover if mineral wool is used		
21		If necessary, a floor protection plate under the appliance		
d _c		From the top of the exhaust vent to the combustible ceiling		1000 mm
d _{c1}		- From the top of the fireplace insert to the underside of the ceiling insulation - In the case of an installed heat exchanger from the top edge of the heat exchanger to the underside of the ceiling insulation		300 mm --- mm
d _{s4}	*	From the back and side edge of the fireplace insert to the inside of the insulation		120 mm
d _{s5}		From the front edge of the fireplace insert to the inside of the insulation		10 mm
d _B		From the bottom of the fireplace insert to the fireproof floor		--- mm

Caution: Fire protection / insulation boards SILCA 250 (SILCA® 250SB, thickness 40 mm) can be replaced by a suitable nonflammable material with a thermal conductivity $\leq 1,1 \text{ W}\cdot\text{m}^{-1}\cdot\text{K}^{-1} (\lambda)$.

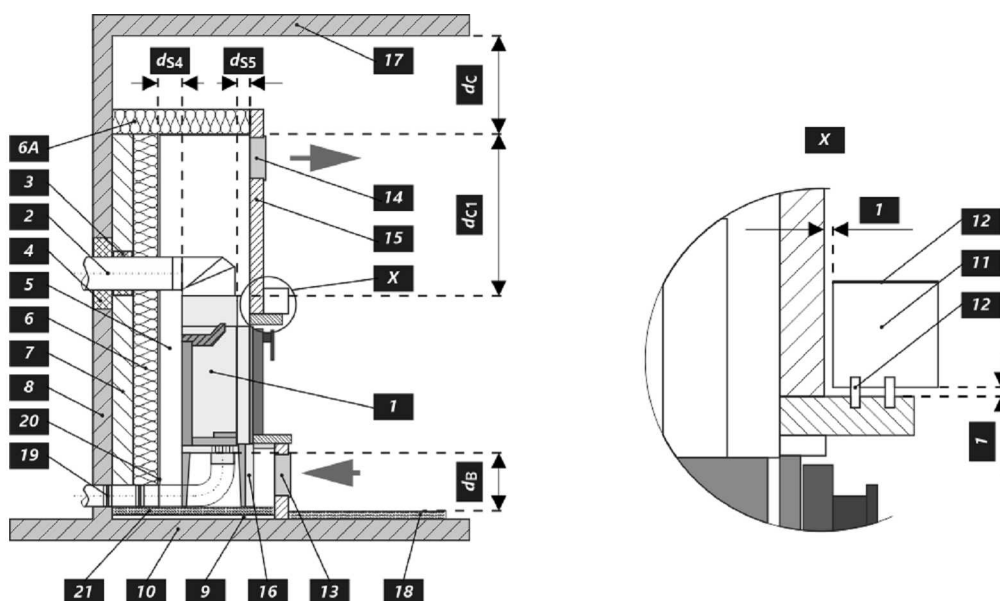

Deklarierte Produkteigenschaften

Harmonisierte technische Spezifikation	EN 13240 ✓ EN 13229	EN 16510 ✓ Ecodesign	✓ DIN+ ✓ BImSchV2	DIBt ✓ 15a B-VG 2015
Produktklassifizierung	Type BE			
Energiewirkungsgrad (η_{nom})	80,2			%
Energieeffizienzindex	106,3			
Energielabel	A			
Brennstoff	Scheitholz			
Brennstofflänge	200-330			mm
Durchschnittlicher Brennstoffverbrauch	2,81			kg/h
Zulässiger Brennstoffverbrauch	3,7			kg/h
Brennstofflieferintervall	1 Stunde			
Verbrennungsluftmenge	35,6			m ³ /h
Nennwärmeleistung (P_{nom})	9,7			kW
Wärmetauscherleistung (P_{Wnom})	---			kW
Maximaler Betriebsüberdruck (p_w)	---			bar
Rauchgasmassenstrom (trocken) für die Berechnung der Rauchgaswege	8,8			g/s
Durchschnittliche Abgastemperatur (T_{nom})	248			°C
Durchschnittliche Rauchgastemperatur hinter dem Stutzen	286			°C
Förderdruck (p_{nom})	12			Pa
Temperaturklasse	T400			
Mehrfachbelegung	Nein			
Lagerung von Brennstoff im Holzfach	Nein			
Maximale Erwärmung des Holzes im Holzfach	---			°C
Feinstaub O ₂ = 13 % (PM_{nom})	20			mg/Nm ³
Abgasemission (CO in den Abgasen bei O ₂ = 13 %) (CO_{nom})	0,0789 986			% mg/Nm ³
OGC O ₂ = 13 % (OGC_{nom})	44			mg/Nm ³
NO _x O ₂ = 13 % (NO_{xnom})	114			mg/Nm ³
Automatische Abbrandsteuerung	---			
Stromverbrauch (W)	---			W
Ständiger Luftverlust (V_h)	---			m ³ _N /h
Intervallbetrieb (INT) / Dauerbetrieb (CON)	INT			

Technische Grunddaten

Hauptabmessungen Höhe (H) Breite (W) Tiefe (L)	1354 848 447	mm
Abmessungen der Brennkammer Höhe (H) Breite (W) Tiefe (L)	472 599 237	mm
Abmessungen der Feuerraumtür Höhe (H) Breite (W) Tiefe (L)	556 629 ---	mm
Achshöhe hinterer (seitlichen) Rauchrohanschluss	1181	mm
Volumen Wärmetauscher	---	l
Rauchrohrdurchmesser	160-180	mm
Abgasstutzen (D_{out})	180	mm
Durchmesser zentrale Luftzufuhr	150	mm
Gewicht	134	kg
Fläche Zuluftgitter	700	cm ²
Fläche Abluftgitter	900	cm ²

Betrieb mit angeschlossener Speichermasse

Minimale aktive Wärme-Strahlungsfläche	4,5	m ²
Durchschnittliche Rauchgastemperatur vor / hinter	398 ---	°C
Maximale Brennstoffmenge	6,8	kg
Leistung Brennkammer	22,0	kW
Nachlegeintervall	---	---
Maximale Brennstoffmenge (eingestelltes Intervall)	---	6,8
Durchschnittliche Leistung (Stunde)	---	---
		kW

Der Kamineinsatz ist unter Einhaltung der Kaminbauvorschriften für den Einsatz in Strahlungsanlagen ohne Konvektionsgitter geeignet.
 Brandschutz- / Dämmplatten für die Strahlungsummantelung ohne Konvektionsgitter aus nicht brennbarem Material mit einer Wärmeleitfähigkeit (λ) $\leq 1,1 \text{ W}\cdot\text{m}^{-1}\cdot\text{K}^{-1}$.

Abstand zu brennbaren Materialien	Bemerkung		
Rückwand (d_R)		800	mm
Strahlungsbereich (d_P)		1000	mm
Strahlungsbereich zum Boden (d_F)		---	mm
Seitenwände (d_S)	*	500	mm
Seite mit Glas (d_{S1})		---	mm
Seite – Nische (d_{S2})		---	mm
Seite – Ausrichtung 45° (d_{S3})		---	mm
Seitliche Strahlung (d_L)		---	mm
Von dem Boden (d_B)		---	mm
Decke (d_C)		1000	mm
Von der hinteren- und seitlichen Kante des Kamineinsatzes bis zur Innenseite der Isolierung (d_{S4})	*	120	mm

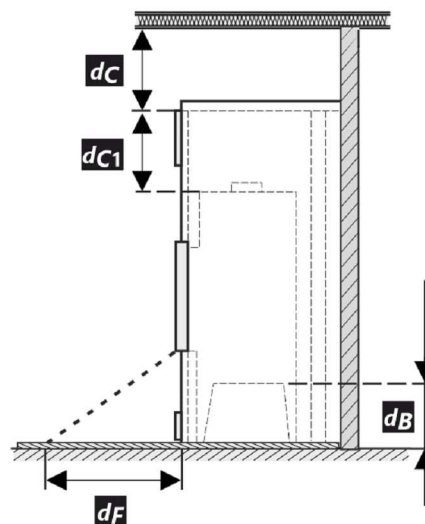
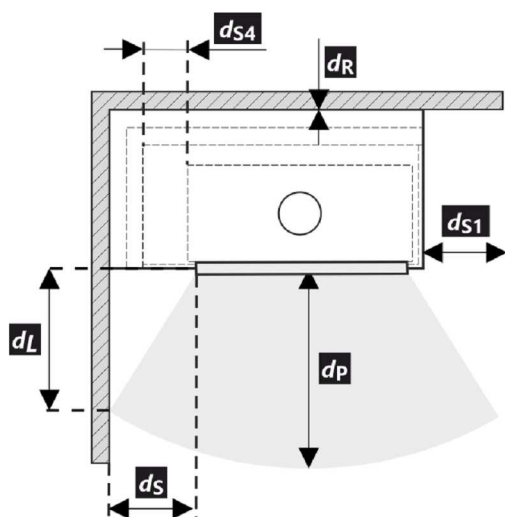

Bei der Installation und dem Betrieb des Ofens sind alle örtlichen Vorschriften sowie nationale und europäische Normen zu beachten.

- * Wenn der Abstand vom Türglas zur brennbaren Seitenwand $d_S < 500 \text{ mm}$ beträgt und nicht $d_{S4} < 120 \text{ mm}$ sein darf, muss diese Wand durch eine 40 mm breite SILCA 250 Dämmplatte oder einen geeigneten Ersatz geschützt werden.

Legende	Bemerkung	Beschreibung	Material	Maß
1	Gerät		205J 0000 002	
2	Rauchgasabgang		metall	DN160-180
3	Isolierung Anschluss Rauchgasabgang			
4	Mineralwolleisolierung			
5	Konvektionsraum um das Gerät			
6	Schutzisolierung der Wände		SILCA 250	2x50 mm
6A	Schutzisolierung der Decke		SILCA 250	80 mm
7	Schutzwand		gebrannter hohlziegel	100 mm
8	Brennbare Wand			
9	Betonplatte			
10	Brennbarer Boden			
11	Dekorativer Träger			
12	Träger mit Belüftungsspalt			
13	Konvektionslufteinlass			700 cm ²
14	Konvektionsluftauslass			900 cm ²
15	Verkleidung		SILCA 250	40 mm
16	Tragrahmen			
17	Brennbare Decke			
18	Schutzisierungsplatte des brennbaren Bodens		SILCA 250	40 mm
19	Verbrennungsluftregulierung			
20	Blechabdeckung bei Verwendung von Mineralwolle			
21	Falls nötig eine Bodenschutzplatte unter dem Gerät			
d_c		Von der Oberkante der Abluftöffnung bis zur brennbaren Decke		1000 mm
d_{c1}		- Von der Oberkante des Kamineinsatzes bis zur Unterkante der Deckenisolierung - Im Falle eines eingebauten Wärmetauschers - von der Oberkante des Wärmetauschers bis zur Unterseite der Deckenisolierung		300 mm --- mm
d_{s4}	*	Von der hinteren- und seitlichen Kante des Kamineinsatzes bis zur Innenseite der Isolierung		120 mm
d_{ss}		Von der Vorderkante des Kamineinsatzes bis zur Innenseite der Isolierung		10 mm
d_B		Von der Unterseite des Kamineinsatzes bis zum feuerfesten Boden		--- mm

Warnhinweise: Brandschutz- / Dämmplatten SILCA 250 (SILCA® 250SB, Dicke 40 mm) kann durch ein geeignetes nicht brennbares Material mit einer Wärmeleitfähigkeit (λ) $\leq 1,1 \text{ W}\cdot\text{m}^{-1}\cdot\text{K}^{-1}$ ersetzt werden.

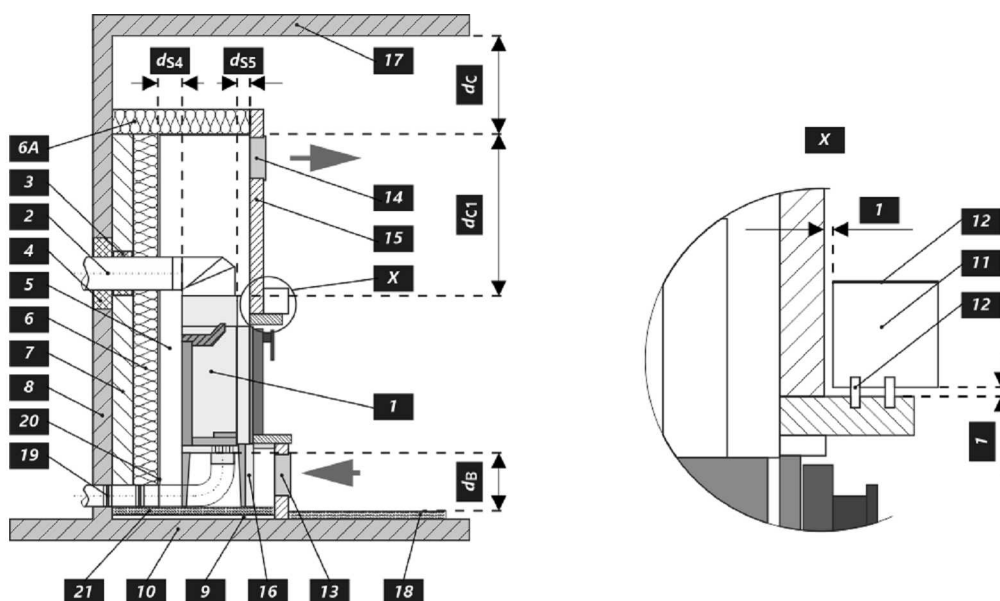

Caractéristiques déclarées du produit

Norme(s) Européennes	EN 13240 ✓ EN 13229	EN 16510 ✓ Ecodesign	✓ DIN+ ✓ BImSchV2	DIBt ✓ 15a B-VG 2015
Classification de l'appareil	Type BE			
Rendement énergétique (η_{nom})				80,2 %
L'indice d'efficacité énergétique EEI				106,3
Label énergétique				A
Combustible				Bûches
Longueur recommandée de bûches				200-330 mm
Consommation moyenne de combustible				2,81 kg/h
Charge en bois autorisé				3,7 kg/h
Intervalle entre les chargements de combustible				1 heure
Débit massique des fumées				35,6 m ³ /h
Puissance nominale (P_{nom})				9,7 kW
Puissance nominale de l'échangeur (P_{Wnom})				--- kW
Surpression maximale de fonctionnement (p_w)				--- bar
Débit massique des gaz de combustion secs pour le calcul des gaz de combustion				8,8 g/s
Température moyenne des résidus de combustion (T_{nom})				248 °C
Température moyenne des résidus de combustion derrière la sortie				286 °C
Tirage de conduit de fumée (p_{nom})				12 Pa
Classe de température				T400
Raccordement à une cheminée collective				Non
Stockage du combustible dans range bûches				Non
Réchauffement maximal du bois dans range bûches				--- °C
Poussière O ₂ = 13 % (PM_{nom})				20 mg/Nm ³
Résidus de combustion émis (CO dans les résidus de combustion pour O ₂ = 13 %) (CO_{nom})				0,0789 % 986 mg/Nm ³
OGC O ₂ = 13 % (OGC_{nom})				44 mg/Nm ³
NOx O ₂ = 13 % (NO_{xnom})				114 mg/Nm ³
Régulation automatique de la combustion				---
La consommation d'électricité (W)				--- W
Standing air loss (V_h)				--- m ³ /h
Fonctionnement par intermittence (INT) / Service ininterrompu (CON)				INT

Données techniques de base

Dimensions principales Hauteur (H) Largeur (W) Profondeur (L)	1354 848 447	mm
Dimensions de la chambre de combustion Hauteur (H) Largeur (W) Profondeur (L)	472 599 237	mm
Dimensions de la porte (du foyer) Hauteur (H) Largeur (W) Profondeur (L)	556 629 ---	mm
Hauteur de l'axe de la sortie arrière (latérale)	1181	mm
Volume de l'échangeur de chaleur	---	l
Diamètre du conduit de fumée	160-180	mm
Diamètre de buse d'air de combustion (D_{out})	180	mm
Diamètre de l'arrivée d'air centrale	150	mm
Poids	134	kg
Zone de la grille de ventilation d'entrée	700	cm ²
Zone de la grille de ventilation de sortie	900	cm ²

Fonctionnement avec masse d'accumulation connectée

Zone radiante active minimale	4,5	m ²
Température moyenne des gaz de combustion devant / derrière	398 ---	°C
Charge maximale en bois	6,8	kg
Puissance du foyer	22,0	kW
Intervalle de rechargement	---	---
Charge maximale en bois (intervalle défini)	---	6,8 kg
Puissance moyenne par heure	---	---

Le foyer peut être utilisé dans des installations rayonnantes sans grille de convection, à condition de respecter les règles de fonctionnement.
 Panneaux ignifuges / isolants pour l'enrobage par rayonnement sans grille de convection en matériau non combustible avec une conductivité thermique $\leq 1,1 \text{ W}\cdot\text{m}^{-1}\cdot\text{K}^{-1}$ (λ).

Isolation protectrice des plafonds
Note

Arrière (d_R)	800	mm
Avant (d_P)	1000	mm
Avant (par rapport au sol) (d_F)	---	mm
Latéral (d_S)	*	500 mm
Latéral avec vitre (d_{S1})	---	mm
Latéral – niche (d_{S2})	---	mm
Latéral – emplacement 45° (d_{S3})	---	mm
Rayonnement latéral (d_L)	---	mm
Depuis le sol (d_B)	---	mm
Plafond (d_C)	1000	mm
Du bord arrière et latéral de l'insert de cheminée jusqu'à l'intérieur de l'isolation (d_{S4})	*	120 mm

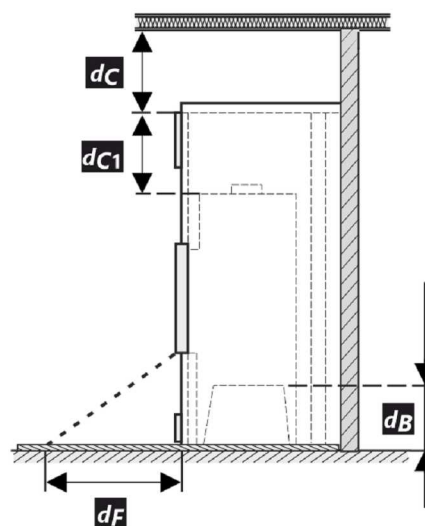
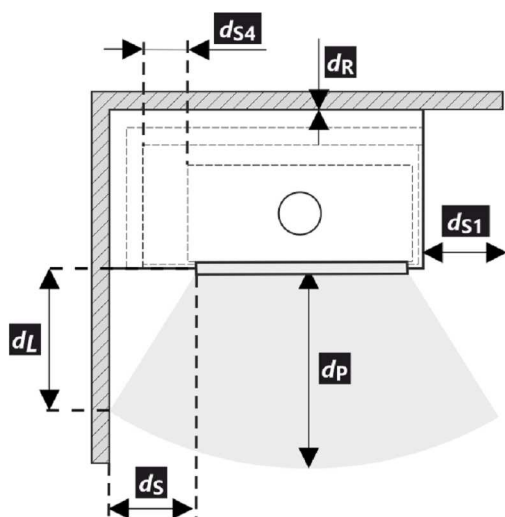

Lors de l'installation et de l'utilisation du produit, toutes les réglementations locales doivent être respectées, y compris celles relatives aux normes nationales et européennes.

- * Si la distance entre la vitre de la porte et la paroi latérale combustible est $d_S < 500$ mm et ne doit pas être $d_{S4} < 120$ mm, cette paroi doit être protégée par un panneau isolant SILCA 250 de 40 mm de large ou un substitut approprié.

Légende	Note	Description	Matériel	Dimension
1		Appareil ménager	205J 0000 002	
2		Extraction des résidus de combustion	métal	DN160-180
3		Isolation du raccordement des résidus de combustion		
4		Isolation minérale		
5		Espace de convection autour de l'appareil		
6		Isolation protectrice des murs	SILCA 250	2x50 mm
6A		Isolation protectrice des plafonds	SILCA 250	80 mm
7		Mur de protection	brique creuse cuite	100 mm
8		Mur inflammable		
9		Plaque de béton		
10		Sol inflammable		
11		Support décoratif / ornemental		
12		Support avec espace de ventilation		
13		Entrée d'air de convection		700 cm ²
14		Sortie d'air de convection		900 cm ²
15		Habillage	SILCA 250	40 mm
16		Cadre de support		
17		Plafond inflammable		
18		Panneau isolant de protection pour sols combustibles	SILCA 250	40 mm
19		Régulation de l'air de combustion		
20		Couverture en tôle si de la laine minérale est utilisée		
21		Si nécessaire, une plaque de sol de protection située sous l'appareil		
d _c		Du haut du conduit d'évacuation au plafond combustible		1000 mm
d _{c1}		- Du haut de l'insert de cheminée jusqu'au bas de l'isolation du plafond - Dans le cas d'un échangeur de chaleur installé - du bord supérieur de l'échangeur de chaleur à la partie inférieure de l'isolation du plafond.		300 mm --- mm
d _{s4}	*	Du bord arrière et latéral de l'insert de cheminée jusqu'à l'intérieur de l'isolation		120 mm
d _{s5}		Du bord avant de l'insert de cheminée à l'intérieur de l'isolation		10 mm
d _B		Du bas de l'insert de cheminée jusqu'au sol incombustible		--- mm

Avertissement: Panneaux ignifuges / isolants SILCA 250 (SILCA® 250SB, épaisseur 40 mm) peut être remplacé par un matériau non combustible approprié avec une conductivité thermique $\leq 1,1 \text{ W}\cdot\text{m}^{-1}\cdot\text{K}^{-1}$ (λ).

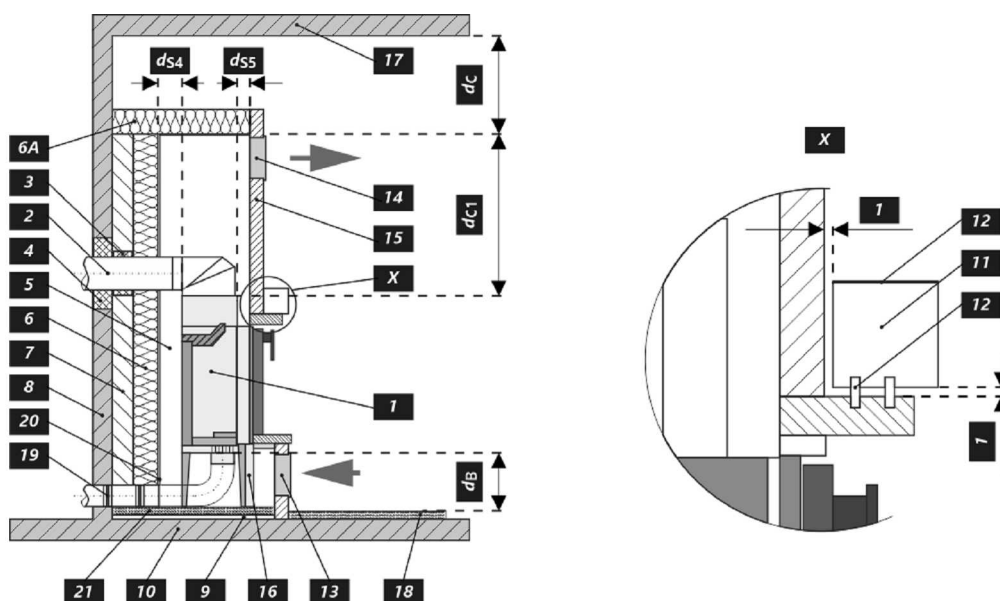

Proprietà dichiarate del prodotto

Specificazioni tecniche armonizzate	EN 13240 ✓ EN 13229	EN 16510 ✓ Ecodesign	✓ DIN+ ✓ BlmSchV2	DIBt ✓ 15a B-VG 2015	
Classificazione del prodotto					Type BE
Efficienza energetica (η_{nom})					80,2 %
Indice di efficienza prodotto					106,3
Etichetta energetica					A
Combustibile					Legna
Combustibile – lunghezza					200-330 mm
Consumo medio di combustibile					2,81 kg/h
Dose ammessa di combustibile					3,7 kg/h
Intervallo di aggiunta di combustibile					1 ora
Quantità di aria di combustione					35,6 m ³ /h
Protenza nominale (P_{nom})					9,7 kW
Protenza nominale dello scambiatore di acqua calda (P_{Wnom})					---
Sovrappressione massima di funzionamento (p_w)					---
Portata dei fumi di scarico secchi per il calcolo delle condotte dei fumi di scarico					8,8 g/s
Temperatura dei gas combusti alla potenza calorica nominale (T_{nom})					248 °C
Temp. media dei gas di scarico al collo alla potenza termica nominale					286 °C
Tiro di esercizio (p_{nom})					12 Pa
Classe di temperatura del camino					T400
Collegamento al camino collettivo					No
Stoccaggio del combustibile nell'area della stufa a legna					No
Riscaldamento massimo della legna nella stufa a legna					---
Polvere O ₂ = 13 % (PM_{nom})					20 mg/Nm ³
Emissioni (CO nei gas comburenti all' O ₂ = 13 %) (CO_{nom})					0,0789 % 986 mg/Nm ³
OGC O ₂ = 13 % (OGC_{nom})					44 mg/Nm ³
NOx O ₂ = 13 % (NO_{Xnom})					114 mg/Nm ³
Controllo automatico della combustione					---
Consumo di energia elettrica (W)					---
Perdita d'aria in piedi (V_h)					---
Funzionamento intermittente (INT) / Funzionamento continuo (CON)					INT

Dati tecnici di base

Dimensioni principali Altezza (H) Larghezza (W) Profondità (L)	1354 848 447	mm
Dimensioni della camera di combustione Altezza (H) Larghezza (W) Profondità (L)	472 599 237	mm
Dimensioni dello sportello del focolare Altezza (H) Larghezza (W) Profondità (L)	556 629 ---	mm
Altezza dell'asse dell'uscita posteriore (laterale)	1181	mm
Volume dello scambiatore di acqua calda	---	l
Diametro del condotto fumario	160-180	mm
Diametro del gola della canna fumaria (D_{out})	180	mm
Diametro dell'afflusso centralizzato di aria	150	mm
Peso	134	kg
Superficie della griglia di aerazione d'ingresso	700	cm ²
Superficie della griglia di aerazione d'uscita	900	cm ²

Funzionamento con massa d'accumulo collegata

Superficie radiante attiva minima	4,5		m ²
Temperatura media dei fumi di scarico prima / dopo	398 ---		°C
Dose massima di combustibile	6,8		kg
Potenza del focolare	22,0		kW
Intervallo di ricarica	---	---	---
Dose massima di combustibile (intervallo impostato)	---	---	6,8 kg
Produzione oraria media	---	---	---
			kW

L'inserto per caminetto è adatto all'uso in installazioni radianti senza griglie di convezione, a condizione che vengano rispettate le regole della stufa.

Pannelli di protezione antincendio / isolamento per rivestimenti radianti senza griglia di convezione in materiale non infiammabile con una conduttività termica $\leq 1,1 \text{ W} \cdot \text{m}^{-1} \cdot \text{K}^{-1} (\lambda)$.

Distanza di materiali infiammabili
Nota

Posteriore (d_R)		800	mm
Anteriore (d_P)		1000	mm
Anteriore (rispetto al pavimento) (d_F)		---	mm
Laterali (d_S)	*	500	mm
Vetrata laterale (d_{S1})		---	mm
Laterali - nicchia (d_{S2})		---	mm
Laterali - posizione 45° (d_{S3})		---	mm
Radiazione laterale (d_L)		---	mm
Dal pavimento (d_B)		---	mm
Dal soffitto (d_C)		1000	mm
Dal bordo posteriore e laterale dell'inserto del caminetto fino all'interno dell'isolazione (d_{S4})	*	120	mm

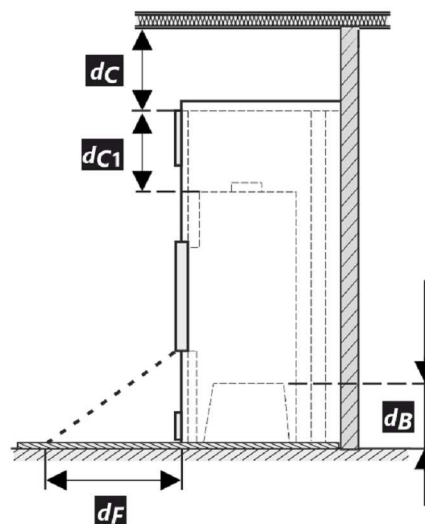
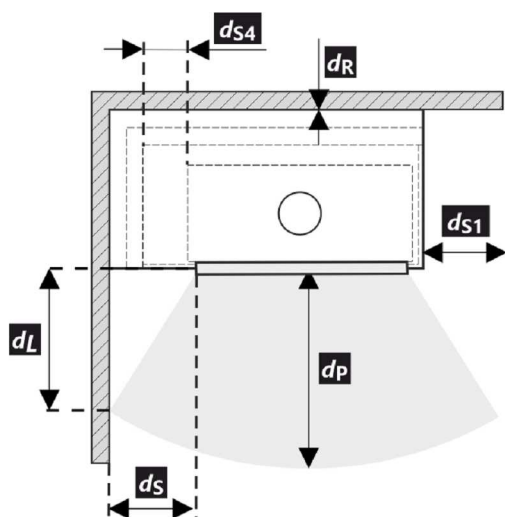

Durante il montaggio e l'uso del prodotto, devono essere rispettate tutte le normative locali, incluse le norme nazionali ed europee.

- * Se la distanza dal vetro della porta alla parete laterale combustibile è $d_S < 500 \text{ mm}$ e non deve essere $d_{S4} < 120 \text{ mm}$, questa parete deve essere protetta da un pannello isolante SILCA 250 largo 40 mm o da un idoneo sostituto.

Legenda	Nota	Descrizione	Materiale	Dimensione
1		Apparecchio	205J 0000 002	
2		Scarico fumi	metallo	DN160-180
3		Isolamento del raccordo scarico fumi		
4		Isolamento minerale		
5		Spazio d'aria di convezione intorno all'insero		
6		Isolazione della parete	SILCA 250	2x50 mm
6A		Isolazione del soffitto	SILCA 250	80 mm
7		Parete di protezione	refrattario trafialto	100 mm
8		Parete ininflamabile		
9		Lastra di calcestruzzo		
10		Pavimento ininflamabile		
11		Trave decorativa		
12		Trave con intercapedine di ventilazione		
13		Ingresso aria di convezione		700 cm ²
14		Uscita aria di convezione		900 cm ²
15		Rivestimento	SILCA 250	40 mm
16		Telaio di supporto		
17		Soffitto ininflamabile		
18		Pannello isolante protettivo per pavimenti ininflamabili	SILCA 250	40 mm
19		Gestione dell'aria comburente		
20		Copertura in lamiera con utilizzo di lana di roccia		
21		Se necessario, piastra di protezione sotto l'apparecchio		
d _c		Dall'alto della bocchetta aria superiore al soffitto combustibile		1000 mm
d _{c1}		- Dalla parte superiore dell'insero caminetto alla parte inferiore dell'isolazione del soffitto - In caso di utilizzo scambiatore di calore, dal bordo superiore dello scambiatore alla parte inferiore dell'isolamento del soffitto		300 mm --- mm
d _{s4}	*	Dal bordo posteriore e laterale dell'insero del caminetto fino all'interno dell'isolazione		120 mm
d _{s5}		Dal bordo anteriore dell'insero caminetto fino all'interno dell'isolazione		10 mm
d _B		Dal fondo dell'insero caminetto al pavimento ignifugo		--- mm

Avviso: I pannelli di protezione antincendio / isolamento SILCA 250 (SILCA® 250SB, spessore 40 mm) possono essere sostituiti da un materiale non ininflamabile adatto con una conduttività termica $\leq 1,1 \text{ W} \cdot \text{m}^{-1} \cdot \text{K}^{-1}$ (λ).

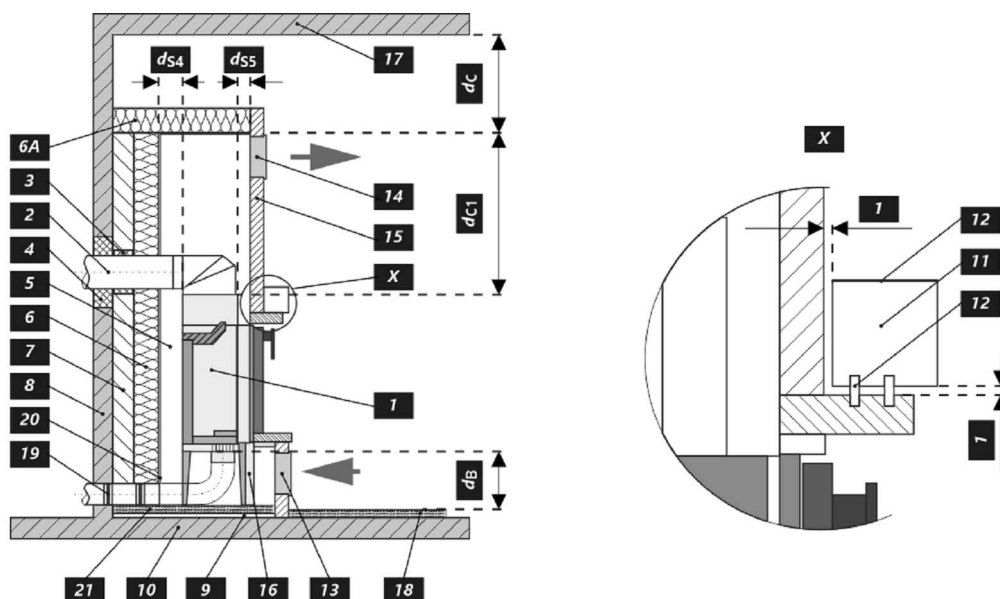

Deklaracija lastnosti

Harmonizirana tehnična specifikacija	EN 13240 ✓ EN 13229	EN 16510 ✓ Ecodesign	✓ DIN+ ✓ BlmSchV2	DIBt ✓ 15a B-VG 2015
Klasifikacija izdelka	Type BE			
Energetska učinkovitost (η_{nom})				80,2 %
Indeks energetske učinkovitosti				106,3
Energijska nalepka				A
Gorivo				Drva
Priporočljiva dolžina goriva				200-330 mm
Povprečna poraba lesa				2,81 kg/h
Dovoljena količina lesa				3,7 kg/h
Interval dobave goriva za nazivno moč				1 ura
Zahtevan zrak za izgorevanje				35,6 m ³ /h
Nazivna moč (P_{nom})				9,7 kW
Izhod toplovodnega izmenjevalnika (P_{Wnom})				---
Delovni tlak (p_w)				---
Masni pretok huhih dimnih plinov				8,8 g/s
Srednja temperatura plinov pri nazivni toplotni moči (T_{nom})				248 °C
Srednja temperatura dimnih plinov po grlu pri nazivni toplotni moči				286 °C
Vlek dimnika (p_{nom})				12 Pa
Temperaturni razred kamina				T400
Priključek na skupni dimnik				Ne
Skladiščenje goriva v območju peči				Ne
Maksimalno segrevanje lesa v območju peči na drva				---
Prah O ₂ = 13 % (PM_{nom})				20 mg/Nm ³
Emisije izgorovalnih plinov (CO v dimne pline pri O ₂ = 13 %) (CO_{nom})				0,0789 % 986 mg/Nm ³
OGC O ₂ = 13 % (OGC_{nom})				44 mg/Nm ³
NO _x O ₂ = 13 % (NO_{xnom})				114 mg/Nm ³
Avtomatska regulacija gorenja				---
Poraba električne energije (W)				---
Stalna izguba zraka (V_h)				---
Prekinjeno delovanje (INT) / Neprekinjeno delovanje (CON)				INT

Osnovni tehnični podatki

Dimenzije Višina (H) Širina (W) Globina (L)	1354 848 447	mm
Dimenzije zgorovalne komore Višina (H) Širina (W) Globina (L)	472 599 237	mm
Dimenzije vrat peči Višina (H) Širina (W) Globina (L)	556 629 ---	mm
Višina osi zadnjega (stranskega) izpusta	1181	mm
Prostornina toplotnega izmenjevalnika	---	l
Premer priključka dimne cevi	160-180	mm
Premer dimne cevi (D_{out})	180	mm
Zunanji dovod zraka (ZDZ)	150	mm
Teža	134	kg
Minimalni presek konvektne odprtine za dovod zraka za nazivno moč	700	cm ²
Minimalni presek konvektne odprtine za odvod zraka za nazivno moč	900	cm ²

Delovanje s priključeno akumulacijsko maso

Najmanjša aktivna sevalna površina	4,5	m ²		
Srednja temperatura dimnih plinov pred / za	398 ---	°C		
Največja količina goriva	6,8	kg		
Moč kurišča	22,0	kW		
Interval dobave goriva za nazivno moč	---	---	---	hod
Največja količina goriva (statičnega intervala)	---	---	6,8	kg
Povprečna urna zmogljivost	---	---	---	kW

Kaminski vložek je pri upoštevanju pravilnika o oskrbi malih kurilnih naprav in predpisov primeren za uporabo v sevalnih ogrevanjih brez konvekcijskih rešetk.
 Protipožarne / izolacijske plošče za sevalne obloge brez konvekcijske rešetke iz negorljivega materiala s toplotno prevodnostjo $\leq 1,1 \text{ W}\cdot\text{m}^{-1}\cdot\text{K}^{-1} (\lambda)$.

Varna razdalja od vnetljivih materialov
Opomba

Zadaj (d_R)	800	mm	
Spredaj (d_P)	1000	mm	
Stran od tal (d_F)	---	mm	
Stran (d_S)	*	500	mm
Stran s steklom (d_{S1})	---	mm	
Stran – niša (d_{S2})	---	mm	
Stran – postavitvev pod kotom 45° (d_{S3})	---	mm	
Stransko sevanje (d_L)	---	mm	
Od tal (d_B)	---	mm	
Od stropa (d_C)	1000	mm	
Od zadnjega in stranskega roba kaminskega vložka do notranje strani izolacije (d_{S4})	*	120	mm

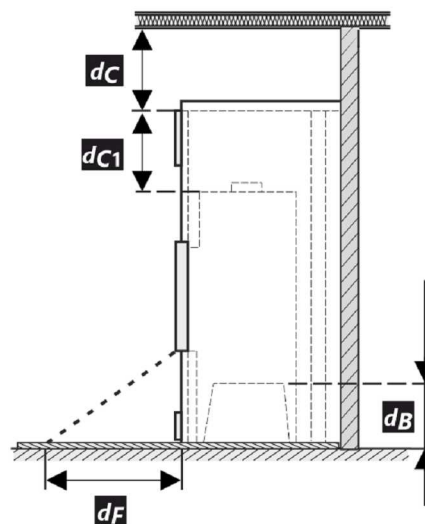
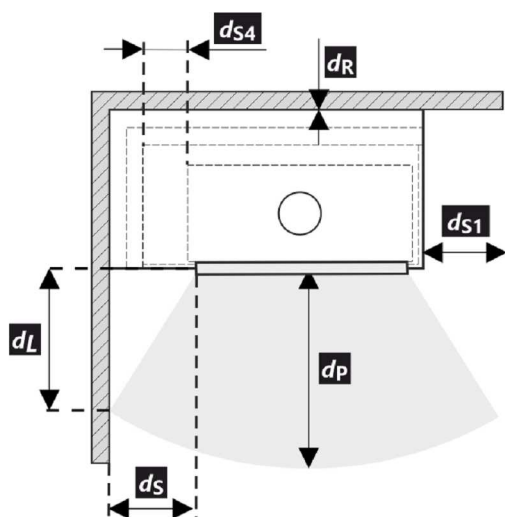

Pri montaži in delovanju izdelka morajo biti upoštevani vsi lokalni predpisi, vključno predpisi, ki se nanašajo na lokalne in Evropske standarde.

- * Če je razdalja od stekla vrat do gorljive stranske stene $d_S < 500 \text{ mm}$, pri čemer ne sme biti $d_{S4} < 120 \text{ mm}$, se mora ta zid zavarovati z izolativno desko SILCA 250 širine 40 mm, ali pa ustreznim nadomestilom.

Legenda	Opomba	Opis	Material	Dimenzija
1		Naprava	205J 0000 002	
2		Odvod dimnih plinov	kov	DN160-180
3		Izolacija priključka za odvod dimnih plinov		
4		Mineralna izolacija		
5		Konvekcijski zračni prostor okoli naprave		
6		Zaščitna izolacija sten	SILCA 250	2x50 mm
6A		Zaščitna izolacija stropa	SILCA 250	80 mm
7		Zaščitna stena	votla žgana opeka	100 mm
8		Gorljiva stena		
9		Betonska plošča		
10		Gorljiva podlaga		
11		Dekorativni / okrasni nosilec		
12		Nosilec s prezračevalno zračno režo		
13		Vhod konvekcijskega zraka		700 cm ²
14		Izhod konvekcijskega zraka		900 cm ²
15		Obloga	SILCA 250	40 mm
16		Nosilni okvir		
17		Gorljiv strop		
18		Zaščitna izolacijska deska	SILCA 250	40 mm
19		Regulacija zraka za izgorevanje		
20		Pločevinasti pokrov v primeru uporabe mineralne volne		
21		Po potrebi zaščitna talna plošča pod napravo		
d_c		Od vrha odvoda zraka do gorljivega stropa		1000 mm
d_{c1}		– Od vrha kaminskega vložka do spodnje strani stropne izolacije – Pri vgrajenem toplotnem izmenjevalniku – od zgornjega roba toplotnega izmenjevalnika do spodnje strani stropne izolacije		300 mm --- mm
d_{s4}	*	Od zadnjega in stranskega roba kaminskega vložka do notranje strani izolacije		120 mm
d_{s5}		Od sprednjega roba kaminskega vložka do notranje strani izolacije		10 mm
d_B		Od dna kaminskega vložka do ognjevarne podlage		--- mm

Opomba: Protipožarne / izolacijske plošče SILCA 250 (SILCA® 250SB, debeline 40 mm) se lahko nadomestijo z ustreznim negorljivim materialom s toplotno prevodnostjo $\leq 1,1 \text{ W} \cdot \text{m}^{-1} \cdot \text{K}^{-1} (\lambda)$.

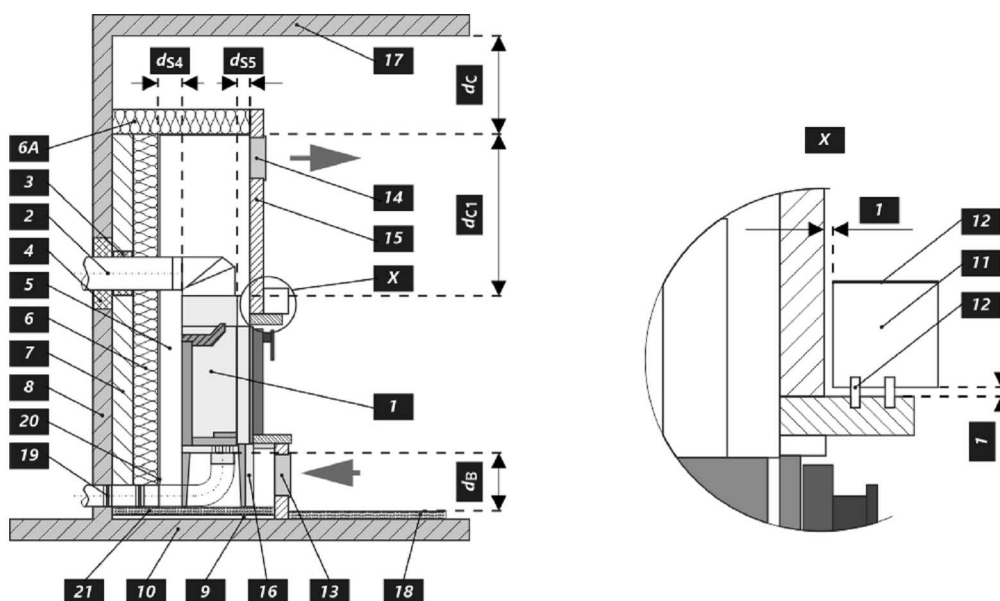

Ilmoitetut ominaisuudet

Yhdenmukaistetut tekniset tiedot	EN 13240 ✓ EN 13229	EN 16510 ✓ Ecodesign	✓ DIN+ ✓ BImSchV2	DIBt ✓ 15a B-VG 2015	
Laitteen luokittelu				Type BE	
Energiatehokkuus (N_{nom})				80,2	%
Energiatehokkuusindeksi				106,3	
Energiamerkintä				A	
Polttoaine				Puuhalot	
Polttopuun pituus				200-330	mm
Keskimääräinen polttoaineenkulutus				2,81	kg/h
Sallittu puumäärä				3,7	kg/h
Puun lisäysväli				1 tunti	
Palamisilman määrä				35,6	m ³ /h
Nimellisteho (P_{nom})				9,7	kW
Vesilämmönsiirtimen teho (P_{Wnom})				---	kW
Suurin käyttöilpaine (p_w)				---	bar
Kuivan savukaasun massavirta savukaasupolun laskemiseksi				8,8	g/s
Savukaasun lämpötila (T_{nom})				248	°C
Savukaasun keskimääräinen lämpötila supistuksen jälkeen				286	°C
Savuputken veto (p_{nom})				12	Pa
Hormin lämpötilaluokka				T400	
Liitäntä yhteiseen hormiin				Ei	
Polttoaineen varastointialue				Ei	
Puun maksimaalinen lämpeneminen varastointialueella				---	°C
Dust O ₂ = 13 % (PM_{nom})				20	mg/Nm ³
Pölykaasupäästöt (CO savukaasuissa, O ₂ = 13 %) (CO_{nom})				0,0789 986	% mg/Nm ³
OGC O ₂ = 13 % (OGC_{nom})				44	mg/Nm ³
NO _x O ₂ = 13 % (NO_{xnom})				114	mg/Nm ³
Automaattinen palamisen säätöyksikkö				---	
Virrankulutus (W)				---	W
Seisovan ilman häviö (V_h)				---	m ³ _N /h
Ajoittainen käyttö (INT) Jatkuva käyttö (CON)				INT	

Tekniset perustiedot

Tärkeimmät mitat Korkeus (H) Leveys (W) Pituus (L)	1354 848 447	mm
Palotilan mitat Korkeus (H) Leveys (W) Pituus (L)	472 599 237	mm
Fireplace door dimensions Korkeus (H) Leveys (W) Pituus (L)	556 629 ---	mm
Takimmaisen (sivu-)ulostuloaukon korkeus	1181	mm
Vesilämmönsiirtimen tilavuus	---	l
Hormin halkaisija	160-180	mm
Savukanavan liitännän halkaisija (D_{out})	180	mm
Ulkoilmaliitännän halkaisija	150	mm
Paino	134	kg
Tuloilmasäleikön pinta-ala	700	cm ²
Poistoilmasäleikön pinta-ala	900	cm ²

Suorituskyky yhdistetyn akkukennon kanssa

Minimaalinen aktiivisesti lämpöä säteilevä pinta	4,5	m ²
Savukaasun keskimääräinen lämpötila ennen / jälkeen	398 ---	°C
Suurin polttoainemäärä	6,8	kg
Takan ulostulo	22,0	kW
Polttoaineen lisäämisen aikaväli	---	---
Suurin polttoainemäärä (säädä aikaväli)	---	6,8 kg
Keskimääräinen tuntituotanto	---	---
		kW

Takkasydän soveltuu käytettäväksi lämmitystakaoissa, joissa ei ole kiertoilmasäleikköä, mikäli takkasääntöjä ja määräyksiä noudatetaan. Palonsuoja- / eristelevyt säteilevään verhoukseen ilman konvektiosäleikköä, jotka on valmistettu syttymättömästä materiaalista, jonka lämmönjohtavuus $\leq 1,1 \text{ W} \cdot \text{m}^{-1} \cdot \text{K}^{-1}$ (λ).

Suojaetäisyydet syttyviin materiaaleihin
Huomautus

Takaosa (d_R)	800	mm
Etuosa (d_P)	1000	mm
Etuosasta lattiaan (d_F)	---	mm
Sivu (d_S)	*	500 mm
Sivu, jossa lasia (d_{S1})	---	mm
Sivu – syvennys (d_{S2})	---	mm
Sivu – sijainti 45° (d_{S3})	---	mm
Sivusäteily (d_L)	---	mm
Lattiasta (d_B)	---	mm
Katosta (d_C)	1000	mm
Välimatkata taka- ja sivureunasta eristyksen sisäpuolelle (d_{S4})	*	120 mm

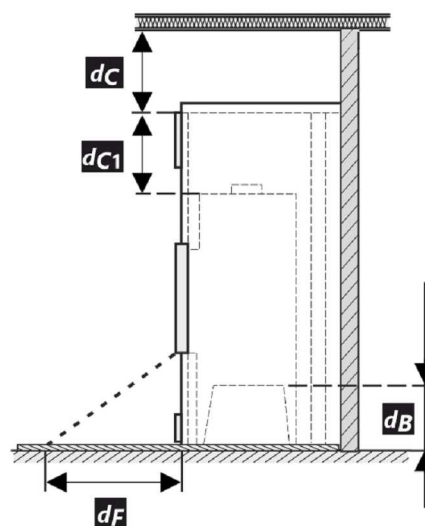
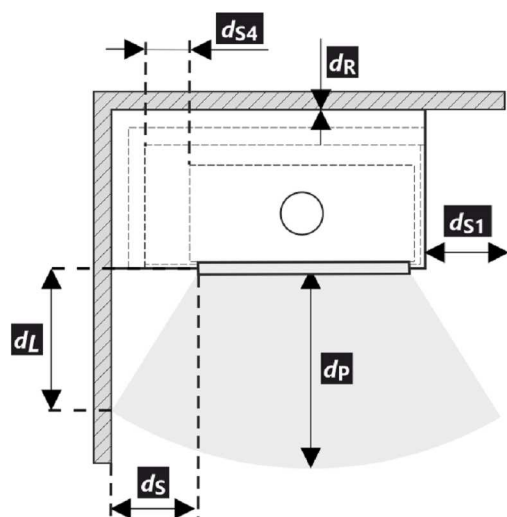

Tuotteen asennuksessa ja käytössä on noudatettava kaikkia paikallisia määräyksiä, mukaan lukien kansallisiin ja eurooppalaisiin standardeihin liittyvät määräykset.

- * Jos etäisyys oven lasista palavaan sivuseinään on $d_S < 500 \text{ mm}$ eikä saa olla $d_{S4} < 120 \text{ mm}$, tämä seinä on suojattava 40 mm leveällä SILCA 250 -eristelevyllä tai sopivalla korvikkeella.

Selite	Huomautus	Kuvaus	Materiaali	Mitat
1		Laite	205J 0000 002	
2		Savukaasun ulostulo	metalli	DN160-180
3		Savukaasuliitännän eristys		
4		Mineraalieristys		
5		Konvektioilmatila laitteen ympärillä		
6		Seinien suojaeristys	SILCA 250	2x50 mm
6A		Katon suojaeristys	SILCA 250	80 mm
7		Suojaseinä	ontto poltettu tiili	100 mm
8		Palava seinä		
9		Betonilaatta		
10		Palava lattia		
11		Peitelevy		
12		Levy, jossa ilmanvaihtoaukko		
13		Konvektioilman tulo		700 cm ²
14		Konvektioilman lähtö		900 cm ²
15		Eristys	SILCA 250	40 mm
16		Tukirunko		
17		Palava katto		
18		Suojaava eristyslevy palavia lattiaita varten	SILCA 250	40 mm
19		Ilmansäädin		
20		Peltikansi, jos käytetään mineraalivillaa		
21		Tarvittaessa lattian suoja levy laitteen alle		
d _c		Poistoilmaventtiilin yläreunasta palavaan kattoon asti		1000 mm
d _{c1}		- Takan yläreunasta kattoeristeen alareunaan - Jos lämmönsiirrin on asennettu, lämmönsiirtimen yläreunasta kattoeristeen alareunaan		300 mm --- mm
d _{s4}	*	Taka- ja sivureunasta eristysten sisäpuolelle		120 mm
d _{s5}		Takan etureunasta eristysten sisäreunaan		10 mm
d _B		Takan alareunasta palamattomaan lattiaan		--- mm

Varoitus: Palonsuoja- / eristelevyt SILCA 250 (SILCA® 250SB, paksuus 40 mm) voidaan korvata sopivalla syttymättömällä materiaalilla, jonka lämmönjohtavuus $\leq 1,1 \text{ W} \cdot \text{m}^{-1} \cdot \text{K}^{-1}$ (λ).

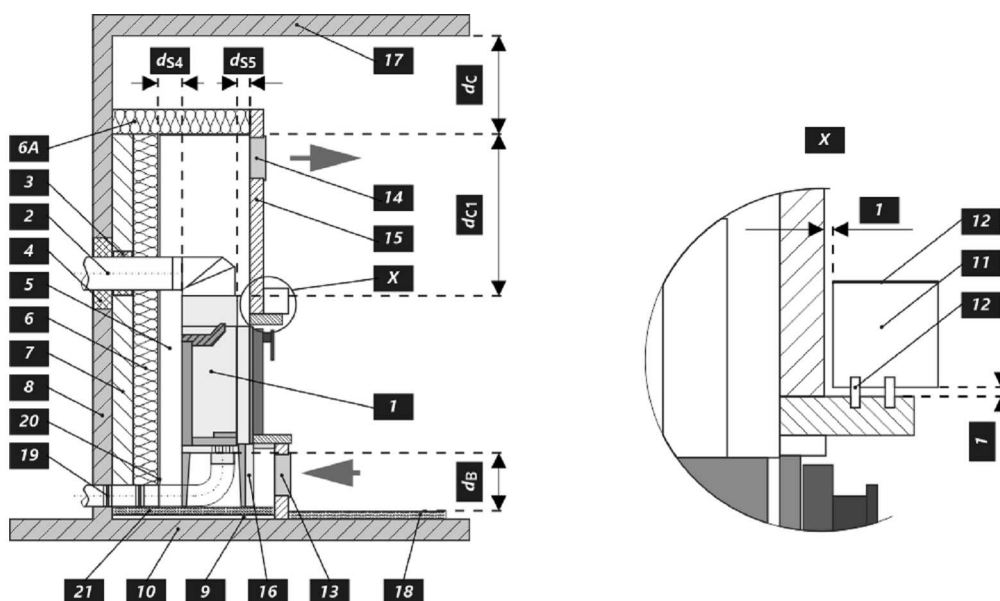

Deklareeritud omadused

Harmoneeritud tehniline spetsifikatsioon	EN 13240 ✓ EN 13229	EN 16510 ✓ Ecodesign	✓ DIN+ ✓ BImSchV2	DIBt ✓ 15a B-VG 2015	
Seadme klassifikatsioon				Type BE	
Energiatõhusus (η_{nom})				80,2	%
Energiatõhususe indeks				106,3	
Energiamärgis				A	
Küttematerjal				Puuhalud	
Küttematerjali pikkus				200-330	mm
Keskmine küttematerjali tarve				2,81	kg/h
Lubatud küttematerjali hulk				3,7	kg/h
Küttematerjali lisamise intervall				1 tund	
Põlemisõhu hulk				35,6	m ³ /h
Nimivõimsus (P_{nom})				9,7	kW
Soojusvaheti võimsus (P_{Wnom})				---	kW
Maksimaalne tööülerõhk (p_w)				---	bar
Suitsugaaside kuivmass suitsugaaside teekonna arvutamiseks				8,8	g/s
Suitsugaasi temperatuur (T_{nom})				248	°C
Suitsugaasi keskmine temperatuuri pärast kraed				286	°C
Suitsutoru tõmme (p_{nom})				12	Pa
Korstna temperatuuriklass				T400	
Ühendus üldkorstnaga				Ei	
Küttematerjali ladustamine puude säilitusalal				Ei	
Puidu maksimaalne soojenemine säilitusalal				---	°C
Tolm O ₂ = 13 % (PM_{nom})				20	mg/Nm ³
Põlemisgaaside emissioon suitsugaaside CO kui O ₂ = 13 % (CO_{nom})				0,0789 986	% mg/Nm ³
OGC O ₂ = 13 % (OGC_{nom})				44	mg/Nm ³
NO _x O ₂ = 13 % (NO_{xnom})				114	mg/Nm ³
Automaatne põlemise reguleerimisseade				---	
Energiatarve (W)				---	W
Seisva õhu kadu (V_h)				---	m ³ _N /h
Vahelduv töö (INT) / Pidev töö (CON)				INT	

Tehnilised põhiandmed

Põhimõõtmed Kõrgus (H) Laius (W) Pikkus (L)	1354 848 447	mm
Põlemiskambri mõõdud Kõrgus (H) Laius (W) Pikkus (L)	472 599 237	mm
Kolde ukse mõõdud Kõrgus (H) Laius (W) Pikkus (L)	556 629 ---	mm
Tagumise (külgmise) väljalaskeava telje kõrgus	1181	mm
Sooja vee soojusvaheti maht	---	l
Suitsutoru diameeter	160-180	mm
Suitsutoru ava diameeter (D_{out})	180	mm
Välisõhu ühenduse diameeter	150	mm
Kaal	134	kg
Sisselaske ventilatsioonivõre	700	cm ²
Väljalaske ventilatsioonivõre	900	cm ²

Toimivus koos ühendatud akumul eeriva elemendiga

Vähim soojust kiirgav pind	4,5	m ²
Lõõrist väljuva gaasi keskmine temperatuur enne / pärast	398 ---	°C
Maksimaalne kütusekogus	6,8	kg
Kambri võimsus	22,0	kW
Laadimise intervall	---	---
Maksimaalne kütusekogus (määratud intervalliga)	---	6,8 kg
Keskmine võimsus tunnis	---	---
		kW

Kaminasüdamikku võib kasutada ilma õhurestita soojust kiirgavates kaminates, kui järgitakse kamina kasutusjuhendit. Tuletõkke- / isolatsiooniplaadid soojust kiirgava kihi loomiseks ilma õhurestita. Valmistatud mittesüttivast materjalis soojusjuhtivusega $\leq 1,1 \text{ W}\cdot\text{m}^{-1}\cdot\text{K}^{-1}$ (λ).

Kaugus põlevatest materjalidest
Märkus

Tagaosa (d_R)		800	mm
Esiosa (d_P)		1000	mm
Esiosast põrandani (d_F)		---	mm
Külg (d_S)	*	500	mm
Klaasiga külg (d_{S1})		---	mm
Külg – nišš (d_{S2})		---	mm
Külg – asend 45° (d_{S3})		---	mm
Kiirgus külje suunas (d_L)		---	mm
Põrandast (d_B)		---	mm
Laest (d_C)		1000	mm
Kaminasüdamiku tagumisest ja külgmisest nurgast isolatsiooni sisemuseni (d_{S4})	*	120	mm

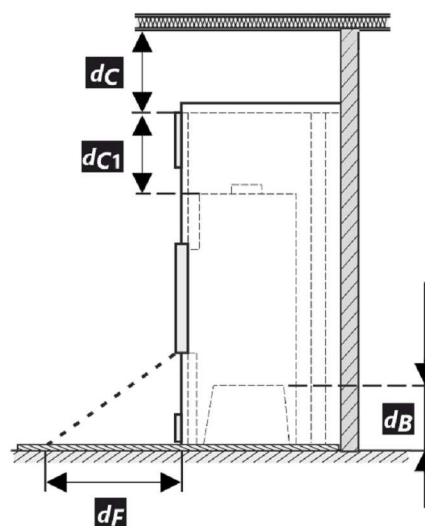
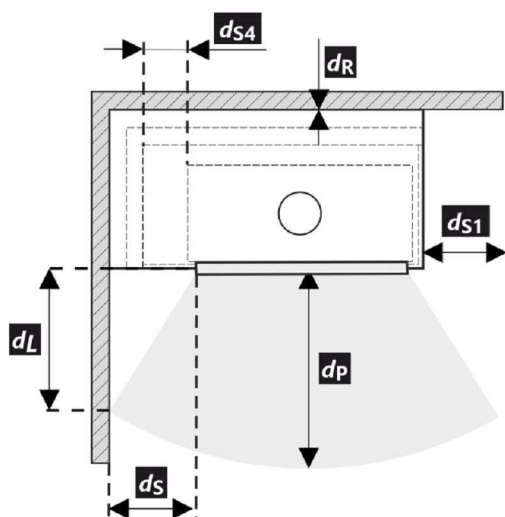

Toote paigaldamise ja kasutamise ajal tuleb järgida kõiki kohalikke määrusi, kaasa arvatud siseriiklikest ja Euroopa standarditest tulenevad määrused.

- * Kui ukseklaasi kaugus süttivast materjalist seinast on $d_S < 500$ mm, ent kui see ei tohiks olla $d_{S4} < 120$ mm, siis tuleb see sein katta 40 mm laiuse SILCA 250 isolatsiooniplaadi või muu võrdväärse materjaliga.

Nr	Märkus	Kirjeldus	Materjal	Mõõdud
1		Seade	205J 0000 002	
2		Suitsugaasi väljalasketoru	metall	DN160-180
3		Suitsugaasi ühenduse soojustus		
4		Mineraalvill		
5		Konvektsiooni õhuruum seadme ümber		
6		Seinte kaitsekiht	SILCA 250	2x50 mm
6A		Seinte kaitsekiht	SILCA 250	80 mm
7		Kaitsesein	põletatud õõnestellis	100 mm
8		Põlev seinamaterjal		
9		Betoonplaat		
10		Põlev pörandmaterjal		
11		Dekoratiivne / mustriline tala		
12		Ventilatsiooni õhupiluga tala		
13		Konvektsiooni sissepuhkevõre		700 cm ²
14		Konvektsiooni väljapuhkevõre		900 cm ²
15		Vooder	SILCA 250	40 mm
16		Tugiraam		
17		Põlev laematerjal		
18		Põlevast materjalist pörandat kaitsev soojustusplaat	SILCA 250	40 mm
19		Põlemisõhu reguleerimine		
20		Metallkate, kui kasutatakse mineraalvilla		
21		Vajdusel seadmealuse pöranda kaitseplaat		
d_c		Väljatõmbeventilatsiooni otsast põleva laematerjalini		1000 mm
d_{c1}		- Kaminasüdamiku tipust lae soojustuse alumise pooleni - Kui on paigaldatud soojusvaheti, siis soojusvaheti ülemisest nurgast lae soojustuse alumise pooleni		300 mm --- mm
d_{s4}	*	Kaminasüdamiku tagumisest ja külgmisest nurgast soojustuse sisepinnani		120 mm
d_{s5}		Kaminasüdamiku eesmisest nurgast soojustuse sisepinnani		10 mm
d_B		Kaminsaüdamiku põhjast tulekindla pörandani		--- mm

Hoiatus: Tuletõkke- / isolatsiooniplaadid SILCA 250 (SILCA® 250SB, paksus 40 mm) võib asendada sobiva mittesüttiva materjaliga, mille soojusjuhtivus on $\leq 1,1 \text{ W} \cdot \text{m}^{-1} \cdot \text{K}^{-1}$ (λ).

